

SIX SIGMA TOOLS® TECHNOLOGY

EDITION 06.2

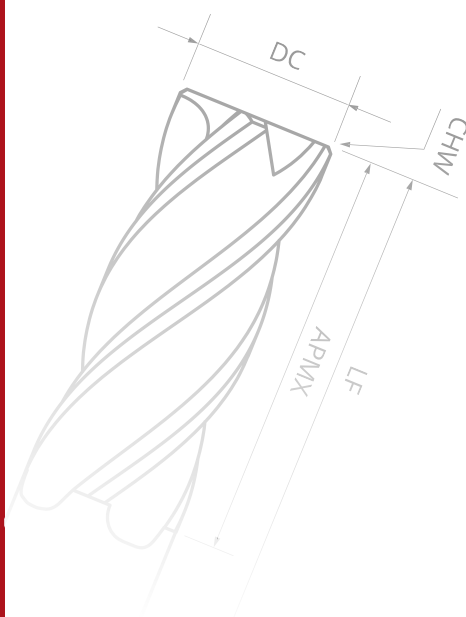

$$v_c = \frac{D_c \times \pi \times n}{1000}$$

$$f = f_z \times Z$$





























































$$v_f = f \times n$$



SIX SIGMA TOOLS®
TECHNOLOGY











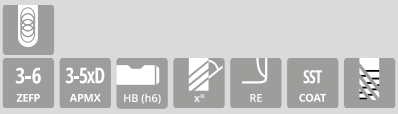



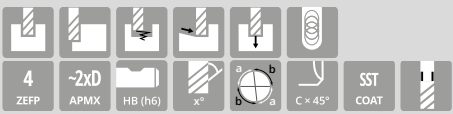

**NEUIGKEITEN UND
ERWEITERUNGEN
UNSERES SORTIMENTS
FÜR EFFIZIENTE ZER-
SPANUNGSPROZESSE**

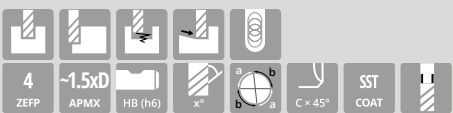
Icons

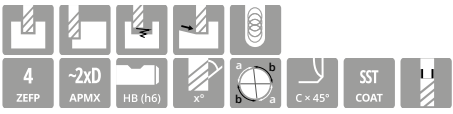
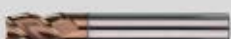

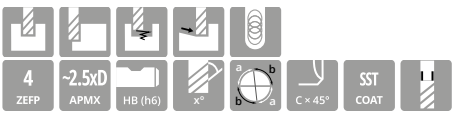







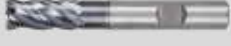

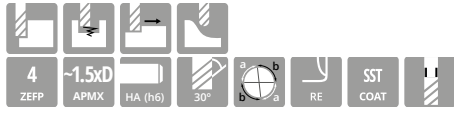

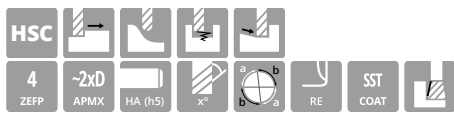

 Stahl	 Rostfreier Stahl	 Superlegierung und Titan	
 Guss	 Gehärteter Stahl	 NE-Metalle	
 Stahl (geeignet)	 Rostfreier Stahl (geeignet)	 Superlegierung und Titan (geeignet)	
 GUSS (geeignet)	 Gehärteter Stahl (geeignet)	 NE-Metalle (geeignet)	
 Vollnutfräsen	 Umfangsfräsen	 Hochgeschwindigkeitsfräsen	 Trochoidalfräsen
 Planfräsen	 3D-Fräsen	 Helixfräsen	 Ramping
 Bohren	 Fasenfräsen	 Vor- und Rückwärts Fasenfräsen	 Senken
 Zentrierbohren	 Vollbohren	 Flachbohren	
 Durchgangsloch	 Sackloch		
 Ungleiche Teilung	 Ungleicher Drallwinkel	 Drallwinkel	 Spitzenwinkel
 Beschichtung	 Unbeschichtet	 Zylinderschaft	 Weldonschaft
 Fase 45°	 Flatland	 Scharfkantig	 Eckenradius
 Kugelfräser	 Lollipopfräser	 Halsfreistellung	 Spanteiler
 Backtaper	 Zentrale Innenkühlung	 Innenkühlung	 Radiale Innenkühlung
 Zähnezahl	 Schrump-Profil	 Längenangabe	 Verhältnis Nutzlänge/ Durchmesser
 Toleranzen	 Metrisch	 Metrisch-fein	 Whitworth
 Gewindetoleranz	 Anschnittform	 DIN-Norm	

ae	Radiale Zustellung	LF	Funktionslänge
ap	Axiale Zustellung	LH	Kopflänge
APMX	Maximale Schnitttiefe	LU	Maximale Nutzlänge
BHTA	Körperkegeleinstellwinkel	n	Drehzahl
CHW	Eckenfasenbreite	RE	Eckenradius
CZCMS	Aufnahmegröße, maschinenseitig	RE_{CAM}	Programmier-Radius
DC	Werkzeugdurchmesser	S	Schneidplattendicke
DCON	Aufnahmedurchmesser, werkstückseitig	SIG	Spitzenwinkel
DCX	Schneidendurchmesser, max.	TDZ	Gewindegröße
DN	Halsdurchmesser	THL	Länge Schneidteil
FTDZ	Größe des Gewindedurchmessers	TOL	Toleranz
fz	Vorschub pro Zahn	TP	Gewindesteigung
h	Maximal verbleibendes Aufmaß	TPI	Gewindegänge je Inch
IC	Inkreisdurchmesser	ULDR	Verhältnis Nutzlänge / Durchmesser
KAPR	Winkel Werkzeugschneidkante	Vc	Schnittgeschwindigkeit
L	Schneidkantenlänge	Vf	Bahngeschwindigkeit
		ZEPF	Anzahl wirksamer Schneiden, umfangseitig

Inhalt



Artikel	Beschreibung	Material und Durchmesserbereich	Bearbeitungen und werkzeugbezogene Eigenschaften	S.
TROCHOIDALFRÄSER				
RCRH	 VHM-Trochoidalfräser	P M K S Ø 3 - 20		08
RCRL	 VHM-Trochoidalfräser	P M K S Ø 4 - 20		10
HOCHLEISTUNGSFRÄSER MIT SCHUTZFASE				
GSXMT 4000	 VHM-Schaftfräser	P M K S Ø 3 - 20		12
GSXMF 4000	 VHM-Schaftfräser FE	P M K S H Ø 1 - 20		14
NEU GSXSVA 4000	 VHM-Schaftfräser VA - kurz	P M K S Ø 4 - 20		16
NEUE MODELLE GSXMVA 4000	 VHM-Schaftfräser VA	P M K S Ø 1 - 25		18
GSXMVA 3000	 VHM-Passfedernutfräser	P M K S N Ø 1 - 16		20
GSXLVA 4000	 VHM-Schaftfräser mit kleinen Fasen	P M K S Ø 3 - 20		24
GCST 5000	 VHM-Schaftfräser - kurz	P M K S Ø 6 - 12		26
GCMT 5000	 VHM-Schaftfräser - lang	P M K S Ø 10 - 16		27

Inhalt



Artikel	Beschreibung	Material und Durchmesserbereich	Bearbeitungen und werkzeugbezogene Eigenschaften	S.
HOCHLEISTUNGSFRÄSER MIT ECKENRADIUS				
GRXFE 4000	 VHM-Torusfräser	P M K S H Ø 3 – 20		28
GCRESN 4000	 VHM-Torusfräser	P K N H Ø 3 – 20		30
NEU GCRELN 4000	 VHM-Torusfräser 5xD	P K N H Ø 3 – 16		34
GCR 4000	 VHM-Torusfräser – bis HRC 55	P M S N H Ø 2 – 12		38
HOCHLEISTUNGSFRÄSER SCHARFKANTIG				
NEUE MODELLE GSSVA 4000	 VHM-Schaftfräser VA	P M S Ø 2.5 – 16		42
GS 4000	 VHM-Schaftfräser – bis HRC 55	P M H Ø 1 – 10		44
HOCHLEISTUNGSFRÄSER-SCHLICHTFRÄSER				
FCZM-HP	 VHM-Präzisions Schlichtfräser < 5 µm	P M K S N Ø 3 – 20		46
HBCBC	 VHM-Tonnenfräser	P K H Ø 5 – 10		48
HBTBC	 VHM-Tonnenfräser – tangential	P K H Ø 3 – 10		52

Artikel	Beschreibung	Material und Durchmesserbereich	Bearbeitungen und werkzeugbezogene Eigenschaften	S.
---------	--------------	---------------------------------	--	----

HOCHLEISTUNGSFRÄSER MIT SCHRUPP-PROFIL



GSXRM 4000	 VHM-Schruppfräser	P M K S Ø 4 - 20		56
-------------------	--	----------------------------	--	----

HOCHVORSCHUBFRÄSER

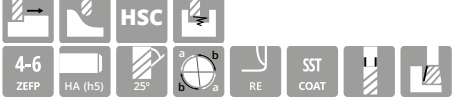
RHCSN	 VHM-Highfeed Fräser	P H Ø 1 - 12		58
--------------	--	------------------------	--	----

NEU RHESN	 VHM-Highfeed Fräser	P H Ø 1 - 12		60
----------------------------	--	------------------------	--	----

HOCHLEISTUNGSKUGELFRÄSER



EFLB 4000	 VHM-Kugelfräser	P K H Ø 1 - 12		62
------------------	---	--------------------------	---	----

NEU USLB 2000	 VHM-Kugelfräser	P H K Ø 1 - 12		64
--------------------------------	--	--------------------------	--	----

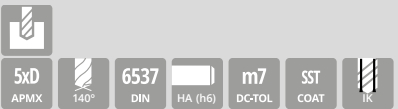
HOCHLEISTUNGS-BOHRWERKZEUGE

SSTD	 VHM-Spiralbohrer	P M S N Ø 3 - 14		66
-------------	---	----------------------------	--	----

GEWINDEWERKZEUGE

TTM	 HSSE-PM-Durchgangsgewindebohrer	P M K N M2 - M20		68
------------	--	----------------------------	--	----

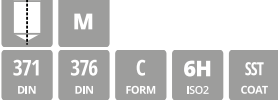













TBM	 HSSE-PM-Sacklochgewindebohrer	P M K N M3 - M20		69
------------	--	----------------------------	--	----

NEUE MODELLE CDTML	 VHM-Zirkularbohr-gewindefräser	P M K S H		70
-------------------------------------	---	------------------	--	----





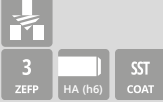

Inhalt

Artikel	Beschreibung	Material und Durchmesserbereich	Bearbeitungen und werkzeugbezogene Eigenschaften	S.
---------	--------------	---------------------------------	--	----

FASEN- UND SENKWERKZEUGE

SST-MT	 Wendepplatten- Multifunktionswerkzeug 90°	P M K S N Ø 16		74
FF060-Z	 VHM-Fasenfräser 60°	P M K S N Ø 4 – 10		76
FF090-Z	 VHM-Fasenfräser 90°	P M K S N Ø 1 – 20		77
FF120-Z	 VHM-Fasenfräser 120°	P M K S N Ø 4 – 10		78
VRE	 VHM-Vor- und Rückwärts Fasenfräser 45°	P M K S N Ø 2 – 16		79
RVRE	 VHM-Vor- und Rückwärts Viertelkreisfräser R0.2 – R1.5	P M K S N Ø 8 – 10		80
KSE090	 VHM-Kegelsenker 90°	P M K S N Ø 4.3 – 31		82
KSE090-UG	 HSS-Kegelsenker ungleich geteilt 90°	P M K S N Ø 4.3 – 31		83

DREHWEENDEPLATTEN

CCGT	 Drehwendepplatten - beschichtet	P M S N		84
DCGT	 Drehwendepplatten - beschichtet	P M S N		84
VCGT	 Drehwendepplatten - beschichtet	P M S N		84

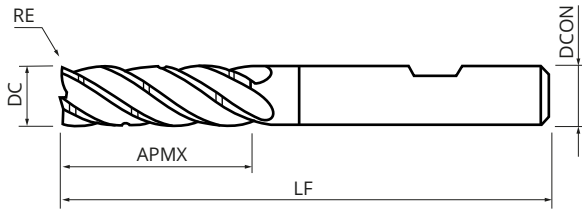

- Zur Anwendung in Stahl, rostfreiem Stahl und Guss
- Mit Spanteiler für kurze Späne

ABMESSUNGEN

Artikelnummer (WGR. 9817)	DC mm	ULDR	APMX mm	LF mm	DCON mm	RE mm	ZEFP
RCRHL 3030R02	3	4xD	12	57	6	0.2	3
RCRHL 4040R02	4	4xD	16	60	6	0.2	4
RCRHL 4050R02	5	4xD	20	62	6	0.2	4
RCRHL 5060R02	6	4xD	24	70	6	0.2	5
RCRHL 5080R02	8	4xD	32	75	8	0.2	5
RCRHM 5100R02	10	3xD	30	80	10	0.2	5
RCRHL 5100R02	10	4xD	40	90	10	0.2	5
RCRHM 6120R03	12	3xD	36	93	12	0.3	6
RCRHL 6120R03	12	4xD	48	105	12	0.3	6
RCRHX 6120R03	12	5xD	60	112	12	0.3	6
RCRHM 6160R03	16	3xD	48	105	16	0.3	6
RCRHL 6160R03	16	4xD	64	120	16	0.3	6
RCRHX 6160R03	16	5xD	80	140	16	0.3	6
RCRHL 6200R05	20	4xD	80	140	20	0.5	6

SCHNITTDATEN

Material		Baustahl								Vergütungsstahl							
DC mm	ULDR	n min ⁻¹	a _p mm	3% a _e		5% a _e		10% a _e		n min ⁻¹	a _p mm	3% a _e		5% a _e		10% a _e	
				Vf mm/ min	a _e mm	Vf mm/ min	a _e mm	Vf mm/ min	a _e mm			Vf mm/ min	a _e mm	Vf mm/ min	a _e mm	Vf mm/ min	a _e mm
3	4 x D	9600	9	1490	0.09	1150	0.15	720	0.3	8400	9	1040	0.09	810	0.15	500	0.3
4	4 x D	9000	13	2800	0.12	2170	0.2	1350	0.4	7900	13	2130	0.12	1650	0.2	1020	0.4
5	4 x D	10100	16	4190	0.15	3250	0.25	2020	0.5	8100	16	3030	0.15	2340	0.25	1460	0.5
6	4 x D	12100	21	9430	0.18	7300	0.3	4540	0.6	10500	21	6810	0.18	5280	0.3	3280	0.6
8	4 x D	9000	29	11690	0.24	9050	0.4	5630	0.8	7900	29	6560	0.24	5080	0.4	3160	0.8
10	3 x D	7900	26	9230	0.3	7150	0.5	4450	1	6900	26	7170	0.3	5550	0.5	3450	1
10	4 x D	7200	35	8410	0.3	6520	0.5	4050	1	6300	35	6540	0.3	5070	0.5	3150	1
12	3 x D	6600	35	11720	0.36	9080	0.6	5650	1.2	5700	35	9060	0.36	7020	0.6	4360	1.2
12	4 x D	6000	43	10660	0.36	8250	0.6	5130	1.2	5200	43	8260	0.36	6400	0.6	3980	1.2
12	5 x D	5100	52	9060	0.36	7020	0.6	4360	1.2	4700	52	7470	0.36	5780	0.6	3600	1.2
16	3 x D	4900	46	9920	0.48	7690	0.8	4780	1.6	4300	46	8040	0.48	6230	0.8	3870	1.6
16	4 x D	4500	57	9110	0.48	7060	0.8	4390	1.6	3900	57	7290	0.48	5650	0.8	3510	1.6
16	5 x D	3800	69	7700	0.48	5960	0.8	3710	1.6	3500	69	6540	0.48	5070	0.8	3150	1.6
20	4 x D	3600	72	8410	0.6	6520	1	4050	2	3100	72	6280	0.6	4860	1	3020	2

Material		Hochlegierter Stahl								Werkzeugstahl							
DC mm	ULDR	n min ⁻¹	a _p mm	3% a _e		5% a _e		10% a _e		n min ⁻¹	a _p mm	3% a _e		5% a _e		10% a _e	
				Vf mm/ min	a _e mm	Vf mm/ min	a _e mm	Vf mm/ min	a _e mm			Vf mm/ min	a _e mm	Vf mm/ min	a _e mm	Vf mm/ min	a _e mm
3	4 x D	7000	9	870	0.09	670	0.15	420	0.3	7500	9	930	0.09	720	0.15	450	0.3
4	4 x D	6400	13	1720	0.12	1330	0.2	830	0.4	6900	13	1860	0.12	1440	0.2	890	0.4
5	4 x D	6500	16	2430	0.15	1880	0.25	1170	0.5	7100	16	2650	0.15	2050	0.25	1280	0.5
6	4 x D	8500	21	5520	0.18	4270	0.3	2660	0.6	9300	21	6040	0.18	4670	0.3	2910	0.6
8	4 x D	6400	29	5320	0.24	4120	0.4	2560	0.8	6900	29	5730	0.24	4440	0.4	2760	0.8
10	3 x D	5600	26	5810	0.3	4500	0.5	2800	1	6100	26	6330	0.3	4910	0.5	3050	1
10	4 x D	5100	35	5300	0.3	4100	0.5	2550	1	5500	35	5710	0.3	4420	0.5	2750	1
12	3 x D	4700	35	7470	0.36	5780	0.6	3600	1.2	5100	35	8100	0.36	6280	0.6	3900	1.2
12	4 x D	4200	43	6670	0.36	5170	0.6	3210	1.2	4600	43	7310	0.36	5660	0.6	3520	1.2
12	5 x D	3600	52	5720	0.36	4430	0.6	2750	1.2	3900	52	6200	0.36	4800	0.6	2980	1.2
16	3 x D	3500	46	6540	0.48	5070	0.8	3150	1.6	3800	46	7100	0.48	5500	0.8	3420	1.6
16	4 x D	3200	57	5980	0.48	4630	0.8	2880	1.6	3400	57	6360	0.48	4920	0.8	3060	1.6
16	5 x D	2700	69	5050	0.48	3910	0.8	2430	1.6	2900	69	5420	0.48	4200	0.8	2610	1.6
20	4 x D	2500	72	5060	0.6	3920	1	2440	2	2700	72	5470	0.6	4230	1	2630	2

Material		Rostfreier Stahl								Guss							
DC mm	ULDR	n min ⁻¹	a _p mm	3% a _e		5% a _e		10% a _e		n min ⁻¹	a _p mm	3% a _e		5% a _e		10% a _e	
				Vf mm/ min	a _e mm	Vf mm/ min	a _e mm	Vf mm/ min	a _e mm			Vf mm/ min	a _e mm	Vf mm/ min	a _e mm	Vf mm/ min	a _e mm
3	4 x D	6900	9	830	0.09	640	0.15	400	0.3	8900	9	1110	0.09	860	0.15	530	0.3
4	4 x D	5700	13	1050	0.12	810	0.2	500	0.4	8300	13	2250	0.12	1740	0.2	1080	0.4
5	4 x D	6400	16	1770	0.15	1370	0.25	850	0.5	8500	16	3190	0.15	2470	0.25	1530	0.5
6	4 x D	7600	21	4160	0.18	3220	0.3	2000	0.6	11100	21	7230	0.18	5600	0.3	3480	0.6
8	4 x D	5700	28	4110	0.24	3180	0.4	1980	0.8	8300	28	6950	0.24	5380	0.4	3350	0.8
10	3 x D	5000	26	5050	0.3	3910	0.5	2430	1	7300	26	7640	0.3	5920	0.5	3680	1
10	4 x D	4500	34	4540	0.3	3520	0.5	2190	1	6600	34	6950	0.3	5380	0.5	3350	1
12	3 x D	4200	35	5520	0.36	4280	0.6	2660	1.2	6100	35	9740	0.36	7550	0.6	4690	1.2
12	4 x D	3800	43	5000	0.36	3870	0.6	2410	1.2	5500	43	8860	0.36	6860	0.6	4270	1.2
12	5 x D	3200	52	4210	0.36	3260	0.6	2030	1.2	4700	52	7550	0.36	5850	0.6	3640	1.2
16	3 x D	3100	46	5360	0.48	4150	0.8	2580	1.6	4500	46	8600	0.48	6660	0.8	4140	1.6
16	4 x D	2800	57	4840	0.48	3750	0.8	2330	1.6	4100	57	7810	0.48	6050	0.8	3760	1.6
16	5 x D	2400	69	4150	0.48	3210	0.8	2000	1.6	3500	69	6660	0.48	5160	0.8	3210	1.6
20	4 x D	2200	72	4950	0.6	3830	1	2380	2	3300	72	6770	0.6	5240	1	3260	2

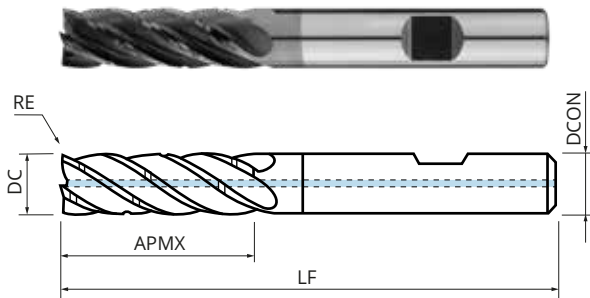

- Zur Anwendung in Stahl, rostfreiem Stahl, Guss und Superlegierungen
- Mit zentraler Innenkühlung für bessere Standzeiten und bessere Späneabfuhr speziell in Taschen
- Mit Spanteiler für kurze Späne

ABMESSUNGEN

Artikelnummer (WGR. 9817)	DC mm	ULDR	APMX mm	LF mm	DCON mm	RE mm	ZEFP
RCRLL 4040R02-IKZ	4	4xD	16	60	6	0.2	4
RCRLL 4050R02-IKZ	5	4xD	20	62	6	0.2	4
RCRLL 5060R02-IKZ	6	4xD	24	70	6	0.2	5
RCRLL 5080R02-IKZ	8	4xD	32	75	8	0.2	5
RCRLM 5100R02-IKZ	10	3xD	30	80	10	0.2	5
RCRLL 5100R02-IKZ	10	4xD	40	90	10	0.2	5
RCRLM 6120R03-IKZ	12	3xD	36	93	12	0.3	6
RCRLL 6120R03-IKZ	12	4xD	48	105	12	0.3	6
RCRLM 6160R03-IKZ	16	3xD	48	105	16	0.3	6
RCRLL 6160R03-IKZ	16	4xD	64	120	16	0.3	6
RCRLL 6200R05-IKZ	20	4xD	80	140	20	0.5	6

SCHNITTDATEN

Material		Baustahl									Werkzeugstahl						
DC mm	ULDR	n min ⁻¹	a _p mm	3% a _e		5% a _e		10% a _e		n min ⁻¹	a _p mm	3% a _e		5% a _e		10% a _e	
				Vf mm/ min	a _e mm	Vf mm/ min	a _e mm	Vf mm/ min	a _e mm			Vf mm/ min	a _e mm	Vf mm/ min	a _e mm	Vf mm/ min	a _e mm
4	4 x D	9500	13	2970	0.12	2300	0.2	1430	0.4	7300	13	1970	0.12	1530	0.2	950	0.4
5	4 x D	10700	16	4440	0.15	3440	0.25	2140	0.5	8100	16	3050	0.15	2360	0.25	1470	0.5
6	4 x D	12700	21	9920	0.18	7690	0.3	4780	0.6	9700	21	6340	0.18	4910	0.3	3050	0.6
8	4 x D	9500	28	12410	0.24	9610	0.4	5980	0.8	7300	28	6080	0.24	4710	0.4	2930	0.8
10	3 x D	8400	26	9820	0.3	7610	0.5	4730	1	6400	26	6710	0.3	5200	0.5	3230	1
10	4 x D	7600	34	8930	0.3	6920	0.5	4300	1	5800	34	6080	0.3	4710	0.5	2930	1
12	3 x D	7000	35	12450	0.36	9640	0.6	6000	1.2	5300	35	8560	0.36	6630	0.6	4120	1.2
12	4 x D	6300	43	11310	0.36	8760	0.6	5450	1.2	4800	43	7760	0.36	6010	0.6	3740	1.2
16	3 x D	5200	46	10640	0.48	8240	0.8	5130	1.6	4000	46	7550	0.48	5850	0.8	3640	1.6
16	4 x D	4700	57	9680	0.48	7490	0.8	4660	1.6	3600	57	6850	0.48	5300	0.8	3300	1.6
20	4 x D	3800	72	8930	0.6	6920	1	4300	2	2900	72	5930	0.6	4590	1	2860	2

Material		Rostfreier Stahl									Guss						
DC mm	ULDR	n min ⁻¹	a _p mm	3% a _e		5% a _e		10% a _e		n min ⁻¹	a _p mm	3% a _e		5% a _e		10% a _e	
				Vf mm/ min	a _e mm	Vf mm/ min	a _e mm	Vf mm/ min	a _e mm			Vf mm/ min	a _e mm	Vf mm/ min	a _e mm	Vf mm/ min	a _e mm
4	4 x D	6300	13	1170	0.12	910	0.2	560	0.4	8300	13	2250	0.12	1740	0.2	1080	0.4
5	4 x D	7100	16	1970	0.15	1530	0.25	950	0.5	8500	16	3190	0.15	2470	0.25	1530	0.5
6	4 x D	8400	21	4650	0.18	3600	0.3	2240	0.6	11100	21	7230	0.18	5600	0.3	3480	0.6
8	4 x D	6300	28	4590	0.24	3560	0.4	2210	0.8	8300	28	6950	0.24	5380	0.4	3350	0.8
10	3 x D	5600	26	5660	0.3	4380	0.5	2720	1	7300	26	7640	0.3	5920	0.5	3680	1
10	4 x D	5000	34	5140	0.3	3980	0.5	2480	1	6600	34	6950	0.3	5380	0.5	3350	1
12	3 x D	4600	35	6140	0.36	4760	0.6	2960	1.2	6100	35	9740	0.36	7550	0.6	4690	1.2
12	4 x D	4200	43	5580	0.36	4320	0.6	2690	1.2	5500	43	8860	0.36	6860	0.6	4270	1.2
16	3 x D	3500	46	6060	0.48	4700	0.8	2920	1.6	4500	46	8600	0.48	6660	0.8	4140	1.6
16	4 x D	3100	57	5510	0.48	4270	0.8	2650	1.6	4100	57	7810	0.48	6050	0.8	3760	1.6
20	4 x D	2500	72	5730	0.6	4440	1	2760	2	3300	72	6770	0.6	5240	1	3260	2

Material		Inconel 625									Titan						
DC mm	ULDR	n min ⁻¹	a _p mm	3% a _e		5% a _e		10% a _e		n min ⁻¹	a _p mm	3% a _e		5% a _e		10% a _e	
				Vf mm/ min	a _e mm	Vf mm/ min	a _e mm	Vf mm/ min	a _e mm			Vf mm/ min	a _e mm	Vf mm/ min	a _e mm	Vf mm/ min	a _e mm
4	4 x D	2300	13	440	0.12	340	0.2	210	0.4	3100	13	580	0.12	450	0.2	280	0.4
5	4 x D	2600	16	740	0.15	570	0.25	350	0.5	3100	16	880	0.15	680	0.25	420	0.5
6	4 x D	3100	21	1830	0.18	1420	0.3	880	0.6	3900	21	2290	0.18	1780	0.3	1100	0.6
8	4 x D	2300	28	1720	0.24	1330	0.4	830	0.8	2900	28	2150	0.24	1660	0.4	1030	0.8
10	3 x D	1900	26	1650	0.3	1280	0.5	790	1	2600	26	2280	0.3	1770	0.5	1100	1
10	4 x D	1900	34	1650	0.3	1280	0.5	790	1	2300	34	2060	0.3	1600	0.5	990	1
12	3 x D	1700	35	2420	0.36	1880	0.6	1160	1.2	2200	35	2670	0.36	2060	0.6	1280	1.2
12	4 x D	1500	43	2200	0.36	1700	0.6	1060	1.2	1900	43	2410	0.36	1860	0.6	1160	1.2
16	3 x D	1300	46	2730	0.48	2110	0.8	1310	1.6	1600	46	2280	0.48	1770	0.8	1100	1.6
16	4 x D	1100	57	2480	0.48	1920	0.8	1190	1.6	1400	57	2060	0.48	1600	0.8	990	1.6
20	4 x D	900	72	2310	0.6	1790	1	1110	2	1100	72	2060	0.6	1600	1	990	2

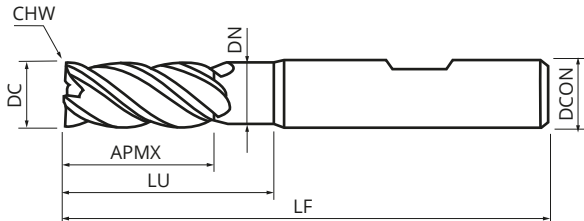

- Besonders gut geeignet zum Tauchfräsen in Stahl und rostfreiem Stahl
- Geeignet für bis zu 45° Ramping-Winkel, 3 – 5° maximaler Helix-Winkel
- Bohrbearbeitung möglich

ABMESSUNGEN

Artikelnummer (WGR. 9814)	DC mm	APMX mm	LU mm	LF mm	DCON mm	DN mm	CHW mm	ZEFP
GSXMT 4030-HB	3	8	15	57	6	2.8	0.15	4
GSXMT 4040-HB	4	11	18	57	6	3.8	0.15	4
GSXMT 4050-HB	5	13	18	57	6	4.8	0.15	4
GSXMT 4060-HB	6	13	20	57	6	5.8	0.2	4
GSXMT 4080-HB	8	19	26	63	8	7.6	0.2	4
GSXMT 4100-HB	10	22	30	72	10	9.5	0.3	4
GSXMT 4120-HB	12	26	36	83	12	11.5	0.35	4
GSXMT 4160-HB	16	32	42	92	16	15.5	0.4	4
GSXMT 4200-HB	20	38	52	104	20	19.5	0.5	4

SCHNITTDATEN

Bearbeitung		VOLLNUTFRÄSEN									
Material	Bemerkung	a_p (xD)	a_e (xD)	Vc m/min	4 mm/Z	6 mm/Z	8 mm/Z	10 mm/Z	12 mm/Z	16 mm/Z	20 mm/Z
Stahl	< 850 N/mm ²	1	1	130 - 150	0.024	0.030	0.040	0.050	0.060	0.080	0.100
	< 1200 N/mm ²	1	1	90 - 110	0.018	0.022	0.028	0.034	0.039	0.049	0.059
	< 1400 N/mm ²	1	1	50 - 70	0.014	0.018	0.024	0.029	0.032	0.041	0.049
Rostfreier Stahl	< 750 N/mm ²	1	1	70 - 90	0.018	0.022	0.028	0.034	0.032	0.049	0.059
	< 950 N/mm ²	0.5	1	50 - 70	0.014	0.017	0.022	0.026	0.030	0.038	0.046
Guss	< 300 HB	1	1	90 - 130	0.018	0.022	0.028	0.034	0.039	0.049	0.059
Superlegierung	Titan < 1100 N/mm ²	0.5	1	30 - 50	0.014	0.017	0.022	0.026	0.030	0.038	0.046
	HRSA < 1300 N/mm ²	0.5	1	30 - 50	0.014	0.017	0.022	0.026	0.030	0.038	0.046

Bearbeitung		UMFANGSFRÄSEN									
Material	Bemerkung	a_p (xD)	a_e (xD)	Vc m/min	4 mm/Z	6 mm/Z	8 mm/Z	10 mm/Z	12 mm/Z	16 mm/Z	20 mm/Z
Stahl	< 850 N/mm ²	1	0.3	150 - 180	0.026	0.035	0.048	0.060	0.075	0.090	0.120
	< 1200 N/mm ²	1	0.3	120 - 150	0.019	0.024	0.032	0.040	0.048	0.056	0.080
	< 1400 N/mm ²	1	0.3	60 - 80	0.018	0.023	0.030	0.036	0.041	0.047	0.063
Rostfreier Stahl	< 750 N/mm ²	1.5	0.5	90 - 110	0.021	0.026	0.034	0.041	0.047	0.052	0.071
	< 950 N/mm ²	1.2	0.3	60 - 80	0.018	0.023	0.030	0.036	0.041	0.047	0.063
Guss	< 300 HB	1	0.3	120 - 150	0.021	0.026	0.034	0.041	0.047	0.052	0.071
Superlegierung	Titan < 1100 N/mm ²	1	0.3	40 - 50	0.026	0.032	0.042	0.050	0.057	0.064	0.078
	HRSA < 1300 N/mm ²	1	0.3	40 - 50	0.026	0.032	0.042	0.050	0.057	0.064	0.078

Bearbeitung		RAMPING									
Material	Bemerkung	α °	a_e (xD)	Vc m/min	4 mm/Z	6 mm/Z	8 mm/Z	10 mm/Z	12 mm/Z	16 mm/Z	20 mm/Z
Stahl	< 850 N/mm ²	45	1	100 - 120	0.015	0.019	0.021	0.024	0.028	0.035	0.043
	< 1200 N/mm ² < 1400 N/mm ²	15	1	55 - 75	0.014	0.017	0.023	0.023	0.026	0.032	0.039
Rostfreier Stahl	< 750 N/mm ²	10	1	60 - 80	0.014	0.018	0.023	0.028	0.032	0.040	0.048
	< 950 N/mm ²	5	1	45 - 65	0.014	0.017	0.022	0.026	0.030	0.038	0.046
Guss	< 300 HB	15	1	60 - 80	0.014	0.018	0.023	0.028	0.032	0.040	0.048
Superlegierung	Titan < 1100 N/mm ²	5	1	30 - 40	0.018	0.023	0.030	0.036	0.042	0.052	0.063
	HRSA < 1300 N/mm ²	5	1	30 - 40	0.018	0.023	0.030	0.036	0.042	0.052	0.063

Bearbeitung		HELIX-FRÄSEN									
Material	Bemerkung	α °	a_e (xD)	Vc m/min	4 mm/Z	6 mm/Z	8 mm/Z	10 mm/Z	12 mm/Z	16 mm/Z	20 mm/Z
Stahl	< 850 N/mm ²	5	0.3	110 - 130	0.014	0.018	0.024	0.030	0.032	0.040	0.048
	< 1200 N/mm ²	4	0.3	70 - 90	0.013	0.016	0.021	0.026	0.029	0.037	0.045
	< 1400 N/mm ²	3	0.3	50 - 70	0.012	0.015	0.019	0.023	0.026	0.032	0.039
Rostfreier Stahl	< 750 N/mm ²	4	0.4	70 - 90	0.013	0.016	0.021	0.026	0.029	0.037	0.045
	< 950 N/mm ²	3	0.4	70 - 90	0.012	0.015	0.019	0.023	0.026	0.036	0.039
Guss	< 300 HB	4	0.4	70 - 90	0.013	0.016	0.021	0.026	0.029	0.037	0.045
Superlegierung	Titan < 1100 N/mm ²	3	0.4	30 - 50	0.011	0.014	0.019	0.021	0.024	0.030	0.037
	HRSA < 1300 N/mm ²	3	0.4	30 - 50	0.011	0.014	0.019	0.021	0.024	0.030	0.037

Bearbeitung		BOHREN									
Material	Bemerkung	a_p (xD)	a_e (xD)	Vc m/min	4 mm/Z	6 mm/Z	8 mm/Z	10 mm/Z	12 mm/Z	16 mm/Z	20 mm/Z
Stahl	< 850 N/mm ²	1	1	85 - 105	0.010	0.012	0.016	0.019	0.022	0.027	0.033
	< 1200 N/mm ²	1	1	55 - 75	0.009	0.011	0.014	0.017	0.019	0.024	0.030
	< 1400 N/mm ²	1	1	55 - 75	0.009	0.011	0.014	0.017	0.019	0.024	0.030
Rostfreier Stahl	< 750 N/mm ² < 950 N/mm ²	1	1	55 - 75	0.009	0.011	0.014	0.017	0.019	0.024	0.030
Guss	< 300 HB	1	1	55 - 75	0.009	0.011	0.014	0.017	0.019	0.024	0.030
Superlegierung	Titan < 1100 N/mm ²	0.5	1	20 - 40	0.010	0.013	0.017	0.021	0.024	0.030	0.036
	HRSA < 1300 N/mm ²	0.5	1	20 - 40	0.010	0.013	0.017	0.021	0.024	0.030	0.036

Bearbeitung		TROCHOIDALFRÄSEN									
Material	Bemerkung	a_p (xD)	a_e (xD)	Vc m/min	4 mm/Z	6 mm/Z	8 mm/Z	10 mm/Z	12 mm/Z	16 mm/Z	20 mm/Z
Stahl	< 850 N/mm ²	2	0.1	160 - 200	0.049	0.061	0.079	0.095	0.108	0.135	0.164
	< 1200 N/mm ²	2	0.1	110 - 130	0.044	0.055	0.071	0.085	0.097	0.122	0.148
	< 1400 N/mm ²	2	0.1	80 - 100	0.039	0.049	0.063	0.076	0.086	0.108	0.131
Rostfreier Stahl	< 750 N/mm ²	2	0.1	110 - 130	0.044	0.055	0.071	0.085	0.097	0.122	0.147
	< 950 N/mm ²	2	0.1	80 - 100	0.039	0.049	0.063	0.076	0.086	0.108	0.131
Guss	< 300 HB	2	0.1	120 - 150	0.044	0.055	0.071	0.085	0.097	0.122	0.148
Superlegierung	Titan < 1100 N/mm ²	2	0.05	50 - 70	0.054	0.067	0.087	0.104	0.119	0.149	0.181
	HRSA < 1300 N/mm ²	2	0.05	50 - 70	0.054	0.067	0.087	0.104	0.119	0.149	0.181

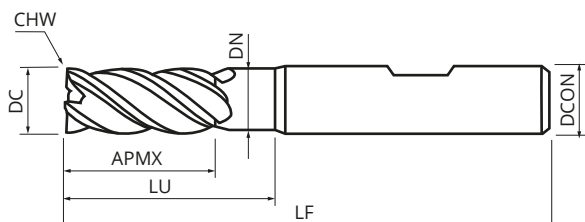

- Besonders gut geeignet in Stahl bis HRC 48 und Guss

ABMESSUNGEN

Artikelnummer (WGR. 9814)	DC mm	APMX mm	LU mm	LF mm	DCON mm	DN mm	CHW mm	ZEFP
GSXMFE 4010-HA	1	2.5	5	57	6	0.8	0.07	4
GSXMFE 4020-HA	2	5	10	57	6	1.8	0.1	4
GSXMFE 4030-HA	3	8	15	57	6	2.8	0.1	4
GSXMFE 4040-HA	4	11	17	57	6	3.8	0.15	4
GSXMFE 4050-HA	5	13	19	57	6	4.8	0.15	4
GSXMFE 4060-HA	6	13	21	57	6	5.8	0.2	4
GSXMFE 4080-HA	8	19	27	63	8	7.6	0.2	4
GSXMFE 4100-HA	10	22	32	72	10	9.5	0.3	4
GSXMFE 4120-HA	12	26	38	83	12	11.5	0.35	4
GSXMFE 4160-HA	16	32	44	92	16	15.5	0.4	4
GSXMFE 4200-HA	20	38	54	104	20	19.5	0.5	4

Artikelnummer (WGR. 9814)	DC mm	APMX mm	LU mm	LF mm	DCON mm	DN mm	CHW mm	ZEFP
GSXMFE 4010-HB	1	2.5	5	57	6	0.8	0.07	4
GSXMFE 4020-HB	2	5	10	57	6	1.8	0.1	4
GSXMFE 4030-HB	3	8	15	57	6	2.8	0.1	4
GSXMFE 4040-HB	4	11	17	57	6	3.8	0.15	4
GSXMFE 4050-HB	5	13	19	57	6	4.8	0.15	4
GSXMFE 4060-HB	6	13	21	57	6	5.8	0.2	4
GSXMFE 4080-HB	8	19	27	63	8	7.6	0.2	4
GSXMFE 4100-HB	10	22	32	72	10	9.5	0.3	4
GSXMFE 4120-HB	12	26	38	83	12	11.5	0.35	4
GSXMFE 4160-HB	16	32	44	92	16	15.5	0.4	4
GSXMFE 4200-HB	20	38	54	104	20	19.5	0.5	4

SCHNITTDATEN

Bearbeitung		VOLLNUTFRÄSEN										
Material	Bemerkung	a_p (xD)	a_e (xD)	V_c m/min	2 mm/Z	4 mm/Z	6 mm/Z	8 mm/Z	10 mm/Z	12 mm/Z	16 mm/Z	20 mm/Z
Stahl	< 850 N/mm ²	1.1	1	110 - 140	0.010	0.020	0.030	0.040	0.050	0.060	0.080	0.100
	< 1200 N/mm ²	1	1	90 - 120	0.008	0.017	0.025	0.034	0.042	0.050	0.065	0.080
	< 1400 N/mm ²	0.8	1	70 - 90	0.007	0.014	0.021	0.028	0.035	0.042	0.049	0.070
Rostfreier Stahl	< 750 N/mm ² < 950 N/mm ²											
Guss	< 300 HB	1	1	80 - 120	0.009	0.017	0.025	0.034	0.042	0.050	0.065	0.080
Superlegierung	Titan < 1100 N/mm ² HRSA < 1300 N/mm ²	0.5	1	30 - 40	0.006	0.012	0.017	0.022	0.026	0.030	0.038	0.046
Gehärteter Stahl	< 300 HB											

Bearbeitung		UMFANGSFRÄSEN										
Material	Bemerkung	a_p (xD)	a_e (xD)	V_c m/min	2 mm/Z	4 mm/Z	6 mm/Z	8 mm/Z	10 mm/Z	12 mm/Z	16 mm/Z	20 mm/Z
Stahl	< 850 N/mm ²	1.5	0.3	150 - 180	0.013	0.026	0.039	0.052	0.065	0.078	0.104	0.130
	< 1200 N/mm ²	1.5	0.3	120 - 150	0.010	0.022	0.033	0.044	0.055	0.065	0.085	0.104
	< 1400 N/mm ²	1.2	0.3	90 - 110	0.009	0.018	0.027	0.036	0.046	0.055	0.064	0.091
Rostfreier Stahl	< 750 N/mm ² < 950 N/mm ²											
Guss	< 300 HB	1.2	0.3	100 - 140	0.012	0.022	0.033	0.044	0.055	0.065	0.085	0.104
Superlegierung	Titan < 1100 N/mm ² HRSA < 1300 N/mm ²	1.2	0.3	40 - 50	0.008	0.016	0.025	0.034	0.044	0.052	0.060	0.070
Gehärteter Stahl	< 300 HB	1.2	0.3	40 - 50	0.005	0.012	0.018	0.025	0.033	0.040	0.048	0.055

Bearbeitung		RAMPING										
Material	Bemerkung	α °	a_e (xD)	V_c m/min	2 mm/Z	4 mm/Z	6 mm/Z	8 mm/Z	10 mm/Z	12 mm/Z	16 mm/Z	20 mm/Z
Stahl	< 850 N/mm ²	2	1	90 - 110	0.006	0.012	0.021	0.031	0.038	0.047	0.051	0.06
	< 1200 N/mm ²	1.5	1	80 - 100	0.005	0.011	0.018	0.026	0.032	0.039	0.044	0.053
	< 1400 N/mm ²	1.5	1	50 - 70	0.005	0.010	0.016	0.023	0.029	0.035	0.038	0.048
Rostfreier Stahl	< 750 N/mm ² < 950 N/mm ²											
Guss	< 300 HB	2	1	100 - 120	0.006	0.012	0.024	0.031	0.042	0.050	0.058	0.067
Superlegierung	Titan < 1100 N/mm ² HRSA < 1300 N/mm ²	1.5	1	50 - 70	0.005	0.011	0.018	0.026	0.032	0.028	0.043	0.052
Gehärteter Stahl	< 300 HB	1	1	50 - 60	0.005	0.008	0.016	0.021	0.060	0.030	0.032	0.041

Bearbeitung		HELIX-FRÄSEN										
Material	Bemerkung	α °	a_e (xD)	V_c m/min	2 mm/Z	4 mm/Z	6 mm/Z	8 mm/Z	10 mm/Z	12 mm/Z	16 mm/Z	20 mm/Z
Stahl	< 850 N/mm ²	2	0.3	110 - 130	0.012	0.025	0.035	0.047	0.060	0.074	0.081	0.094
	< 1200 N/mm ²	1.5	0.3	90 - 110	0.010	0.023	0.030	0.041	0.051	0.060	0.068	0.084
	< 1400 N/mm ²	1.5	0.3	70 - 90	0.009	0.020	0.026	0.037	0.047	0.055	0.060	0.075
Rostfreier Stahl	< 750 N/mm ² < 950 N/mm ²											
Guss	< 300 HB	2	0.3	100 - 120	0.012	0.028	0.038	0.050	0.065	0.077	0.085	0.095
Superlegierung	Titan < 1100 N/mm ² HRSA < 1300 N/mm ²	1.5	0.3	50 - 70	0.008	0.011	0.018	0.023	0.029	0.035	0.036	0.046
Gehärteter Stahl	< 300 HB	1	0.3	50 - 60	0.008	0.018	0.023	0.031	0.039	0.047	0.052	0.065

Bearbeitung		TROCHOIDALFRÄSEN										
Material	Bemerkung	a_p (xD)	a_e (xD)	V_c m/min	2 mm/Z	4 mm/Z	6 mm/Z	8 mm/Z	10 mm/Z	12 mm/Z	16 mm/Z	20 mm/Z
Stahl	< 850 N/mm ²	2	0.1	240 - 270	0.031	0.061	0.092	0.123	0.153	0.184	0.245	0.307
	< 1200 N/mm ²	2	0.1	190 - 210	0.024	0.053	0.079	0.106	0.132	0.156	0.204	0.250
	< 1400 N/mm ²	2	0.1	130 - 160	0.02	0.040	0.060	0.080	0.102	0.122	0.142	0.202
Rostfreier Stahl	< 750 N/mm ² < 950 N/mm ²											
Guss	< 300 HB	2	0.1	180 - 210	0.028	0.051	0.077	0.103	0.128	0.152	0.198	0.243
Superlegierung	Titan < 1100 N/mm ² HRSA < 1300 N/mm ²	2	0.1	60 - 80	0.018	0.036	0.056	0.077	0.099	0.117	0.135	0.158
Gehärteter Stahl	< 300 HB	1.5	0.1	50 - 60	0.011	0.026	0.040	0.055	0.073	0.088	0.106	0.121

GSXSVA 4000 VHM-Schaftfräser VA – kurz



NEU

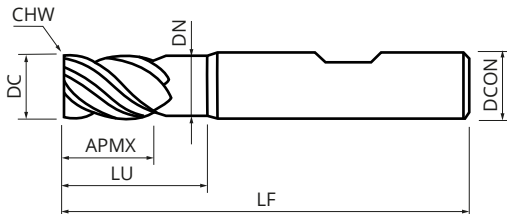

- Besonders gut geeignet in rostfreiem Stahl, Titan und Stahl

ABMESSUNGEN

Artikelnummer (WGR. 9814)	DC mm	APMX mm	LU mm	LF mm	DCON mm	DN mm	CHW mm	ZEFP
GSXSVA 4040-HB	4	8	15	54	6	3.8	0.15	4
GSXSVA 4050-HB	5	9	15	54	6	4.8	0.15	4
GSXSVA 4060-HB	6	10	17	54	6	5.8	0.2	4
GSXSVA 4080-HB	8	12	21	58	8	7.6	0.2	4
GSXSVA 4100-HB	10	14	24	66	10	9.5	0.3	4
GSXSVA 4120-HB	12	16	26	73	12	11.5	0.35	4
GSXSVA 4160-HB	16	22	32	82	16	15.5	0.4	4
GSXSVA 4200-HB	20	26	40	92	20	19.5	0.5	4

SCHNITTDATEN

Bearbeitung		VOLLNUTFRÄSEN									
Material	Bemerkung	a_p (xD)	a_e (xD)	Vc m/min	4 mm/Z	6 mm/Z	8 mm/Z	10 mm/Z	12 mm/Z	16 mm/Z	20 mm/Z
Stahl	< 850 N/mm ²	1	1	130 - 150	0.022	0.032	0.043	0.054	0.065	0.076	0.108
	< 1200 N/mm ²	0.7	1	90 - 120	0.016	0.024	0.030	0.037	0.042	0.048	0.064
	< 1400 N/mm ²	0.5	1	80 - 100	0.015	0.023	0.030	0.038	0.045	0.053	0.076
Rostfreier Stahl	< 750 N/mm ²	1	1	70 - 90	0.016	0.024	0.030	0.037	0.042	0.048	0.064
	< 950 N/mm ²	0.5	1	50 - 70	0.013	0.018	0.024	0.028	0.032	0.037	0.050
Guss	< 300 HB	1	1	90 - 130	0.016	0.024	0.030	0.037	0.042	0.048	0.064
Superlegierung	Titan < 1100 N/mm ²	0.5	1	30 - 50	0.013	0.018	0.024	0.028	0.032	0.037	0.050
	HRSA < 1300 N/mm ²	0.3	1	20-30	0.010	0.013	0.018	0.024	0.027	0.032	0.043

Bearbeitung		UMFANGSFRÄSEN									
Material	Bemerkung	a_p (xD)	a_e (xD)	Vc m/min	4 mm/Z	6 mm/Z	8 mm/Z	10 mm/Z	12 mm/Z	16 mm/Z	20 mm/Z
Stahl	< 850 N/mm ²	1.5	0.4	150 - 180	0.028	0.042	0.056	0.070	0.084	0.112	0.140
	< 1200 N/mm ²	1.2	0.3	120 - 150	0.024	0.036	0.048	0.059	0.070	0.092	0.112
	< 1400 N/mm ²	1	0.3	90 - 110	0.019	0.029	0.039	0.050	0.059	0.069	0.098
Rostfreier Stahl	< 750 N/mm ²	1.5	0.4	90 - 110	0.019	0.028	0.037	0.044	0.051	0.056	0.077
	< 950 N/mm ²	1.2	0.3	60 - 80	0.017	0.025	0.032	0.039	0.044	0.051	0.068
Guss	< 300 HB	1	0.3	120 - 150	0.019	0.028	0.037	0.044	0.051	0.056	0.077
Superlegierung	Titan < 1100 N/mm ²	1	0.3	40 - 50	0.024	0.035	0.045	0.054	0.060	0.067	0.084
	HRSA < 1300 N/mm ²	0.7	0.3	20-30	0.013	0.027	0.378	0.043	0.054	0.059	0.065

Bearbeitung		RAMPING									
Material	Bemerkung	α °	a_e (xD)	Vc m/min	4 mm/Z	6 mm/Z	8 mm/Z	10 mm/Z	12 mm/Z	16 mm/Z	20 mm/Z
Stahl	< 850 N/mm ²	3	1	100 - 120	0.011	0.016	0.023	0.030	0.038	0.049	0.054
	< 1200 N/mm ² < 1400 N/mm ²	2	1	90 - 110	0.009	0.011	0.014	0.018	0.022	0.027	0.035
Rostfreier Stahl	< 750 N/mm ²	3	1	70 - 90	0.009	0.011	0.016	0.021	0.026	0.031	0.038
	< 950 N/mm ²	2	1	50 - 70	0.008	0.009	0.011	0.016	0.022	0.028	0.035
Guss	< 300 HB	2	0.3	100-130	0.011	0.016	0.023	0.030	0.038	0.049	0.054
Superlegierung	Titan < 1100 N/mm ²	2	0.5	40-50	0.013	0.018	0.024	0.028	0.032	0.037	0.050
	HRSA < 1300 N/mm ²	1	0.3	30-40	0.009	0.011	0.016	0.021	0.026	0.031	0.038

Bearbeitung		HELIX-FRÄSEN									
Material	Bemerkung	α °	a_e (xD)	Vc m/min	4 mm/Z	6 mm/Z	8 mm/Z	10 mm/Z	12 mm/Z	16 mm/Z	20 mm/Z
Stahl	< 850 N/mm ²	5	0.3	100 - 120	0.013	0.019	0.025	0.030	0.036	0.042	0.050
	< 1200 N/mm ² < 1400 N/mm ²	4	0.3	90 - 110	0.011	0.016	0.022	0.027	0.032	0.039	0.045
	< 750 N/mm ²	4	0.4	70 - 90	0.011	0.016	0.022	0.027	0.032	0.039	0.045
Rostfreier Stahl	< 950 N/mm ²	3	0.4	50 - 70	0.009	0.011	0.016	0.021	0.026	0.031	0.038
Guss	< 300 HB	2	0.3	100-130	0.019	0.028	0.037	0.044	0.051	0.056	0.077
Superlegierung	Titan < 1100 N/mm ²	2	0.2	40-50	0.011	0.016	0.022	0.027	0.032	0.039	0.045
	HRSA < 1300 N/mm ²	1	0.1	30-40	0.009	0.011	0.016	0.021	0.026	0.031	0.038

Bearbeitung		TROCHOIDALFRÄSEN									
Material	Bemerkung	a_p (xD)	a_e (xD)	Vc m/min	4 mm/Z	6 mm/Z	8 mm/Z	10 mm/Z	12 mm/Z	16 mm/Z	20 mm/Z
Stahl	< 850 N/mm ²	1.2	0.1	240 - 270	0.043	0.099	0.133	0.166	0.199	0.265	0.331
	< 1200 N/mm ² < 1400 N/mm ²	1.2	0.1	190 - 210	0.038	0.086	0.114	0.143	0.168	0.220	0.270
	< 750 N/mm ²	1.2	0.1	130 - 160	0.032	0.065	0.086	0.110	0.132	0.154	0.218
Rostfreier Stahl	< 950 N/mm ²	1.2	0.1	110-130	0.040	0.072	0.119	0.140	0.151	0.180	0.200
Guss	< 300 HB	1.2	0.1	80 - 100	0.038	0.070	0.097	0.113	0.130	0.157	0.177
Superlegierung	Titan < 1100 N/mm ²	1.2	0.1	120 - 150	0.019	0.083	0.111	0.139	0.164	0.214	0.262
	HRSA < 1300 N/mm ²	1.2	0.1	70 - 90	0.018	0.059	0.097	0.119	0.130	0.161	0.194
		1.2	0.1	30-40	0.016	0.038	0.052	0.065	0.076	0.097	0.108



**NEUE*
MODELLE**

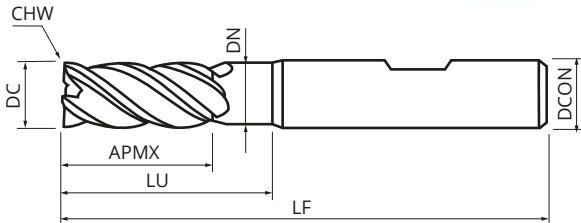

- Besonders gut geeignet in rostfreiem Stahl, Titan und Stahl

ABMESSUNGEN

Artikelnummer (WGR. 9814)	DC mm	APMX mm	LU mm	LF mm	DCON mm	DN mm	CHW mm	ZEFP
* GSXMVA 4010	1	2.5	5	57	6	0.8	0.07	4
* GSXMVA 4015	1.5	3.8	7.5	57	6	1.3	0.07	4
* GSXMVA 4020	2	5	10	57	6	1.8	0.1	4
* GSXMVA 4025	2.5	6.3	12.5	57	6	2.3	0.1	4
GSXMVA 4030	3	8	15	57	6	2.8	0.1	4
GSXMVA 4040	4	11	17	57	6	3.8	0.15	4
GSXMVA 4050	5	13	19	57	6	4.8	0.15	4
GSXMVA 4060	6	13	21	57	6	5.8	0.2	4
GSXMVA 4080	8	19	27	63	8	7.6	0.2	4
GSXMVA 4100	10	22	32	72	10	9.5	0.3	4
GSXMVA 4120	12	26	38	83	12	11.5	0.35	4
GSXMVA 4160	16	32	44	92	16	15.5	0.4	4
GSXMVA 4200	20	38	54	104	20	19.5	0.5	4
* GSXMVA 4250	25	45	65	121	25	24.5	0.6	4

SCHNITTDATEN

Bearbeitung		VOLLNUTFRÄSEN											
Material	Bemerkung	a_p (xD)	a_e (xD)	Vc m/min	2 mm/Z	4 mm/Z	6 mm/Z	8 mm/Z	10 mm/Z	12 mm/Z	16 mm/Z	20 mm/Z	25 mm/Z
Stahl	< 850 N/mm ²	1	1	130 - 150	0.012	0.020	0.030	0.040	0.050	0.060	0.070	0.100	0.120
	< 1200 N/mm ²	0.7	1	90 - 120	0.009	0.015	0.022	0.028	0.034	0.039	0.044	0.059	0.071
	< 1400 N/mm ²	0.5	1	80 - 100	0.008	0.014	0.021	0.028	0.035	0.042	0.049	0.070	0.084
Rostfreier Stahl	< 750 N/mm ²	1	1	70 - 90	0.009	0.015	0.022	0.028	0.034	0.039	0.044	0.059	0.071
	< 950 N/mm ²	0.5	1	50 - 70	0.007	0.012	0.017	0.022	0.026	0.030	0.034	0.046	0.055
Guss	< 300 HB	1	1	90 - 130	0.009	0.015	0.022	0.028	0.034	0.039	0.044	0.059	0.071
Superlegierung	Titan < 1100 N/mm ²	0.5	1	30 - 50	0.007	0.012	0.017	0.022	0.026	0.030	0.034	0.046	0.055
	HRSA < 1300 N/mm ²	0.3	1	20-30	0.005	0.009	0.012	0.017	0.022	0.025	0.030	0.040	0.045

Bearbeitung		UMFANGSFRÄSEN											
Material	Bemerkung	a_p (xD)	a_e (xD)	Vc m/min	2 mm/Z	4 mm/Z	6 mm/Z	8 mm/Z	10 mm/Z	12 mm/Z	16 mm/Z	20 mm/Z	25 mm/Z
Stahl	< 850 N/mm ²	2	0.4	150 - 180	0.013	0.026	0.039	0.052	0.065	0.078	0.104	0.130	0.156
	< 1200 N/mm ²	1.5	0.3	120 - 150	0.010	0.022	0.033	0.044	0.055	0.065	0.085	0.104	0.125
	< 1400 N/mm ²	1.2	0.3	90 - 110	0.009	0.018	0.027	0.036	0.046	0.055	0.064	0.091	0.109
Rostfreier Stahl	< 750 N/mm ²	1.5	0.4	90 - 110	0.011	0.018	0.026	0.034	0.041	0.047	0.052	0.071	0.085
	< 950 N/mm ²	1.5	0.3	60 - 80	0.009	0.016	0.023	0.030	0.036	0.041	0.047	0.063	0.076
Guss	< 300 HB	1.5	0.3	120 - 150	0.011	0.018	0.026	0.034	0.041	0.047	0.052	0.071	0.085
Superlegierung	Titan < 1100 N/mm ²	1.5	0.3	40 - 50	0.013	0.022	0.032	0.042	0.050	0.056	0.062	0.078	0.094
	HRSA < 1300 N/mm ²	1	0.3	20-30	0.005	0.012	0.025	0.0350	0.040	0.050	0.055	0.060	0.080

Bearbeitung		RAMPING											
Material	Bemerkung	α °	a_e (xD)	Vc m/min	2 mm/Z	4 mm/Z	6 mm/Z	8 mm/Z	10 mm/Z	12 mm/Z	16 mm/Z	20 mm/Z	25 mm/Z
Stahl	< 850 N/mm ²	3	1	100 - 120	0.006	0.010	0.015	0.021	0.028	0.035	0.045	0.050	0.060
	< 1200 N/mm ² < 1400 N/mm ²	2	1	90 - 110	0.005	0.008	0.010	0.013	0.017	0.020	0.025	0.032	0.038
Rostfreier Stahl	< 750 N/mm ²	3	1	70 - 90	0.005	0.008	0.010	0.015	0.019	0.024	0.029	0.035	0.042
	< 950 N/mm ²	2	1	50 - 70	0.004	0.007	0.008	0.010	0.015	0.020	0.026	0.032	0.038
Guss	< 300 HB	2	0.3	100-130	0.006	0.010	0.015	0.021	0.028	0.035	0.045	0.050	0.060
Superlegierung	Titan < 1100 N/mm ²	2	0.5	40-50	0.007	0.012	0.017	0.022	0.026	0.030	0.034	0.046	0.055
	HRSA < 1300 N/mm ²	1	0.3	30-40	0.005	0.008	0.010	0.015	0.019	0.024	0.029	0.035	0.042

Bearbeitung		HELIX-FRÄSEN											
Material	Bemerkung	α °	a_e (xD)	Vc m/min	2 mm/Z	4 mm/Z	6 mm/Z	8 mm/Z	10 mm/Z	12 mm/Z	16 mm/Z	20 mm/Z	25 mm/Z
Stahl	< 850 N/mm ²	5	0.3	100 - 120	0.008	0.012	0.018	0.023	0.028	0.033	0.039	0.046	0.055
	< 1200 N/mm ² < 1400 N/mm ²	4	0.3	90 - 110	0.006	0.010	0.015	0.020	0.025	0.030	0.036	0.042	0.050
Rostfreier Stahl	< 750 N/mm ²	4	0.4	70 - 90	0.006	0.010	0.015	0.020	0.025	0.030	0.036	0.042	0.050
	< 950 N/mm ²	3	0.4	50 - 70	0.005	0.008	0.010	0.015	0.019	0.024	0.029	0.035	0.042
Guss	< 300 HB	2	0.3	100-130	0.006	0.010	0.015	0.021	0.028	0.035	0.045	0.050	0.060
Superlegierung	Titan < 1100 N/mm ²	2	0.2	40-50	0.006	0.010	0.015	0.020	0.025	0.030	0.036	0.042	0.050
	HRSA < 1300 N/mm ²	1	0.1	30-40	0.005	0.008	0.010	0.015	0.019	0.024	0.029	0.035	0.042

Bearbeitung		TROCHOIDALFRÄSEN											
Material	Bemerkung	a_p (xD)	a_e (xD)	Vc m/min	2 mm/Z	4 mm/Z	6 mm/Z	8 mm/Z	10 mm/Z	12 mm/Z	16 mm/Z	20 mm/Z	25 mm/Z
Stahl	< 850 N/mm ²	2	0.1	240 - 270	0.025	0.040	0.092	0.123	0.153	0.184	0.245	0.307	0.315
	< 1200 N/mm ²	2	0.1	190 - 210	0.022	0.035	0.079	0.106	0.132	0.156	0.204	0.250	0.270
	< 1400 N/mm ²	2	0.1	130 - 160	0.020	0.030	0.060	0.080	0.102	0.122	0.142	0.202	0.220
Rostfreier Stahl	< 750 N/mm ²	2	0.1	110-130	0.014	0.037	0.067	0.110	0.130	0.140	0.167	0.185	0.195
	< 950 N/mm ²	2	0.1	80 - 100	0.012	0.035	0.065	0.090	0.105	0.120	0.145	0.164	0.180
Guss	< 300 HB	2	0.1	120 - 150	0.011	0.018	0.077	0.103	0.128	0.152	0.198	0.243	0.260
Superlegierung	Titan < 1100 N/mm ²	2	0.1	70 - 90	0.010	0.017	0.055	0.090	0.110	0.120	0.149	0.180	0.195
	HRSA < 1300 N/mm ²	2	0.1	30-40	0.009	0.015	0.035	0.048	0.060	0.070	0.090	0.100	0.110

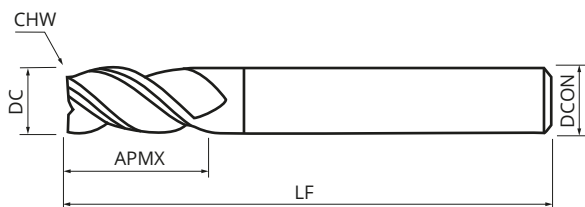

- Universell einsetzbares Fräs Werkzeug, besonders geeignet für instabile Bearbeitungen
- Spezielle Geometrie zur Herstellung von Passfedernuten
- Minustoleranz

ABMESSUNGEN

Artikelnummer (WGR. 9814)	DC mm	APMX mm	LF mm	DCON mm	CHW mm	TOL mm	ZEFP
GSXMVA 3010	1	2	38	4	-	-0.02/-0.035	3
GSXMVA 3011	1.1	2.2	38	4	-	-0.02/-0.035	3
GSXMVA 3012	1.2	2.4	38	4	-	-0.02/-0.035	3
GSXMVA 3013	1.3	2.6	38	4	-	-0.02/-0.035	3
GSXMVA 3014	1.4	2.8	38	4	-	-0.02/-0.035	3
GSXMVA 3015	1.5	3	38	4	-	-0.02/-0.035	3
GSXMVA 3016	1.6	3.2	38	4	-	-0.02/-0.035	3
GSXMVA 3017	1.7	3.4	38	4	-	-0.02/-0.035	3
GSXMVA 3018	1.8	3.6	38	4	-	-0.02/-0.035	3
GSXMVA 3019	1.9	3.8	38	4	-	-0.02/-0.035	3
GSXMVA 3020	2	4	38	6	-	-0.02/-0.035	3
GSXMVA 3021	2.1	4.2	38	6	-	-0.02/-0.035	3
GSXMVA 3022	2.2	4.4	38	6	-	-0.02/-0.035	3
GSXMVA 3023	2.3	4.6	38	6	-	-0.02/-0.035	3
GSXMVA 3024	2.4	4.8	38	6	-	-0.02/-0.035	3
GSXMVA 3025	2.5	5	38	6	0.1	-0.02/-0.035	3
GSXMVA 3026	2.6	5.2	38	6	0.1	-0.02/-0.035	3
GSXMVA 3027	2.7	5.4	38	6	0.1	-0.02/-0.035	3
GSXMVA 3028	2.8	5.6	50	6	0.1	-0.02/-0.035	3
GSXMVA 3029	2.9	5.8	50	6	0.1	-0.02/-0.035	3
GSXMVA 3030	3	6	50	6	0.1	-0.02/-0.035	3
GSXMVA 3031	3.1	7	50	6	0.1	-0.025/-0.04	3
GSXMVA 3032	3.2	7	50	6	0.1	-0.025/-0.04	3
GSXMVA 3033	3.3	7	50	6	0.1	-0.025/-0.04	3
GSXMVA 3034	3.4	7	50	6	0.1	-0.025/-0.04	3
GSXMVA 3035	3.5	8	50	6	0.1	-0.025/-0.04	3

ABMESSUNGEN

Artikelnummer (WGR. 9814)	DC mm	APMX mm	LF mm	DCON mm	CHW mm	TOL mm	ZEFP
GSXMVA 3038	3.8	8	54	6	0.1	-0.025/-0.04	3
GSXMVA 3039	3.9	8	54	6	0.1	-0.025/-0.04	3
GSXMVA 3040	4	8	54	6	0.1	-0.025/-0.04	3
GSXMVA 3045	4.5	10	54	6	0.1	-0.025/-0.04	3
GSXMVA 3048	4.8	10	54	6	0.1	-0.025/-0.04	3
GSXMVA 3050	5	10	54	6	0.1	-0.025/-0.04	3
GSXMVA 30575	5.75	13	54	6	0.1	-0.025/-0.04	3
GSXMVA 3060	6	13	54	6	0.15	-0.025/-0.04	3
GSXMVA 3070	7	16	58	8	0.15	-0.03/-0.05	3
GSXMVA 30775	7.75	19	58	8	0.15	-0.03/-0.05	3
GSXMVA 3080	8	19	58	8	0.15	-0.03/-0.05	3
GSXMVA 3090	9	19	66	10	0.15	-0.03/-0.05	3
GSXMVA 3097	9.7	22	66	10	0.15	-0.03/-0.05	3
GSXMVA 3100	10	22	66	10	0.2	-0.03/-0.05	3
GSXMVA 3117	11.7	26	73	12	0.2	-0.035/-0.055	3
GSXMVA 3120	12	26	73	12	0.2	-0.035/-0.055	3
GSXMVA 3137	13.7	26	75	14	0.2	-0.035/-0.055	3
GSXMVA 3140	14	26	75	14	0.2	-0.035/-0.055	3
GSXMVA 3157	15.7	30	82	16	0.2	-0.035/-0.055	3
GSXMVA 3160	16	30	82	16	0.2	-0.035/-0.055	3

Material	Stahl / legierter Stahl										
	< 850 N/mm										
	Bohren			Vollnutfräsen				Schlichten			
DC mm	n min ⁻¹	Vf mm/min	a _p Step mm	n min ⁻¹	Vf mm/min	a _p mm	a _e mm	n min ⁻¹	Vf mm/min	a _p mm	a _e mm
1.0	31850	287	1	19110	287	1	1	22930	344	1	0.1
bis 1.5	21240	255	1.5	18050	407	1.5	1.5	21660	488	1.5	0.1
bis 2.0	15930	287	2	17520	526	2	2	21020	631	2	0.1
bis 2.5	12740	268	2.5	15290	574	2.5	2.5	20390	765	2.5	0.1
bis 3.0	12740	344	3	12740	574	3	3	16990	765	3	0.2
bis 4.0	9560	430	4	9560	574	4	4	12740	765	4	0.2
bis 5.0	8920	401	5	7650	574	5	5	10200	765	5	0.2
bis 6.0	7440	401	6	6370	574	6	6	8500	765	6	0.2
bis 7.0	6370	344	7	5460	574	7	7	7280	765	7	0.2
bis 8.0	5580	334	8	4780	574	8	8	6370	765	8	0.2
bis 9.0	4960	297	8	4250	574	9	9	5670	766	9	0.2
bis 10.0	4460	334	8	3830	575	10	10	5100	765	10	0.2
bis 12.0	3720	334	8	3190	575	12	12	4250	765	12	0.2
bis 14.0	3190	382	8	2730	574	14	14	3640	765	14	0.2
bis 16.0	2790	334	4	2390	574	16	16	3190	766	16	0.2

SCHNITTDATEN

Material	Stahl / legierter Stahl										
	< 1300 N/mm										
	Bohren			Vollnutfräsen				Schlichten			
DC mm	n min ⁻¹	Vf mm/min	a _p Step mm	n min ⁻¹	Vf mm/min	a _p mm	a _e mm	n min ⁻¹	Vf mm/min	a _p mm	a _e mm
1.0	25480	229	1	17520	169	1	1	22930	207	1	0.1
bis 1.5	16990	204	1.5	16990	240	1.5	1.5	21660	293	1.5	0.1
bis 2.0	12740	229	2	12740	241	2	2	21020	373	2	0.1
bis 2.5	10200	214	2.5	10200	242	2.5	2.5	20390	453	2.5	0.1
bis 3.0	10620	287	3	8500	240	3	3	16990	454	3	0.2
bis 4.0	7970	358	4	6370	239	4	4	12740	451	4	0.2
bis 5.0	7650	344	5	5100	241	5	5	10200	453	5	0.2
bis 6.0	6370	344	6	4250	240	6	6	8500	495	6	0.2
bis 7.0	5460	295	7	3640	240	7	7	7280	494	7	0.2
bis 8.0	4780	287	8	3190	240	8	8	6370	495	8	0.2
bis 9.0	4250	255	8	2840	241	9	9	5670	495	9	0.2
bis 10.0	3830	287	8	2550	240	10	10	5100	495	10	0.2
bis 12.0	3190	287	8	2130	240	12	12	4250	495	12	0.2
bis 14.0	2730	328	8	1820	240	14	14	3640	494	14	0.2
bis 16.0	2390	287	4	1600	240	16	16	3190	495	16	0.2

Material	Rostfreier Stahl										
	ferritisch und martensitisch										
	Bohren			Vollnutfräsen				Schlichten			
DC mm	n min ⁻¹	Vf mm/min	a _p Step mm	n min ⁻¹	Vf mm/min	a _p mm	a _e mm	n min ⁻¹	Vf mm/min	a _p mm	a _e mm
1.0	22300	201	0.5	19110	230	1	1	22930	303	1	0.1
bis 1.5	14870	178	0.75	19110	344	1.5	1.5	21660	429	1.5	0.1
bis 2.0	11150	201	1	18320	440	2	2	21020	549	2	0.1
bis 2.5	8920	187	1.25	15290	459	2.5	2.5	20390	667	2.5	0.1
bis 3.0	9560	258	1.5	12740	459	3	3	16990	668	3	0.2
bis 4.0	7170	322	2	9560	459	4	4	12740	666	4	0.2
bis 5.0	6060	272	2.5	7650	459	5	5	10200	668	5	0.2
bis 6.0	5050	272	3	6370	522	6	6	8500	765	6	0.2
bis 7.0	4330	233	3.5	5460	523	7	7	7280	765	7	0.2
bis 8.0	3790	227	4	4780	522	8	8	6370	765	8	0.2
bis 9.0	3370	202	4.5	4250	523	9	9	5670	766	9	0.2
bis 10.0	3030	227	5	3830	523	10	10	5100	765	10	0.2
bis 12.0	2530	227	4	3190	523	12	12	4250	765	12	0.2
bis 14.0	2170	259	4	2730	522	14	14	3640	765	14	0.2
bis 16.0	1900	227	4	2390	522	16	16	3190	766	16	0.2

SCHNITTDATEN

Material	Rostfreier Stahl										
	austenitisch										
	Bohren			Vollnutfräsen				Schlichten			
DC mm	n min ⁻¹	Vf mm/min	a _p Step mm	n min ⁻¹	Vf mm/min	a _p mm	a _e mm	n min ⁻¹	Vf mm/min	a _p mm	a _e mm
1.0	19110	172	0.3	17520	163	0.3	1	22930	221	0.3	0.1
bis 1.5	12740	153	0.45	16990	235	0.5	1.5	21660	306	0.5	0.1
bis 2.0	9560	172	0.6	12740	234	0.7	2	19110	362	0.7	0.1
bis 2.5	7650	161	0.75	10200	233	0.8	2.5	15290	363	0.8	0.1
bis 3.0	8500	229	0.9	8500	233	1	3	12740	360	1	0.2
bis 4.0	6370	287	1.2	6370	234	1.3	4	9560	359	1.3	0.2
bis 5.0	4780	215	1.5	5100	233	1.7	5	7650	361	1.7	0.2
bis 6.0	3990	215	1.8	4250	248	2	6	6370	383	6	0.2
bis 7.0	3420	184	2.1	3640	247	2.3	7	5460	384	7	0.2
bis 8.0	2990	179	2.4	3190	248	2.6	8	4780	383	8	0.2
bis 9.0	2660	159	2.7	2840	248	3	9	4250	383	9	0.2
bis 10.0	2390	179	3	2550	248	3.3	10	3830	384	10	0.2
bis 12.0	2000	179	3.6	2130	248	4	12	3190	383	12	0.2
bis 14.0	1710	205	4	1820	247	4.6	14	2730	383	14	0.2
bis 16.0	1500	179	4	1600	249	5.3	16	2390	383	16	0.2

Material	Superlegierung										
	Bohren			Vollnutfräsen				Schlichten			
DC mm	n min ⁻¹	Vf mm/min	a _p Step mm	n min ⁻¹	Vf mm/min	a _p mm	a _e mm	n min ⁻¹	Vf mm/min	a _p mm	a _e mm
1.0	11150	100	0.33	19110	178	0.3	1	22300	208	0.3	0.1
bis 1.5	7440	89	0.49	12740	176	0.5	1.5	14870	206	0.5	0.1
bis 2.0	5580	100	0.66	9560	175	0.7	2	11150	205	0.7	0.1
bis 2.5	4460	94	0.82	7650	175	0.8	2.5	8920	204	0.8	0.1
bis 3.0	4780	129	0.99	6370	174	1	3	7440	204	1	0.2
bis 4.0	3590	161	1.32	4780	175	1.3	4	5580	205	1.3	0.2
bis 5.0	3190	143	1.65	3830	175	1.7	5	4460	204	1.7	0.2
bis 6.0	2660	143	1.98	3190	192	2	6	3720	224	2	0.2
bis 7.0	2280	123	2.31	2730	192	2.3	7	3190	224	2.3	0.2
bis 8.0	2000	119	2.64	2390	192	2.6	8	2790	224	8	0.2
bis 9.0	1770	106	2.97	2130	192	3	9	2480	224	9	0.2
bis 10.0	1600	119	3.3	1920	193	3.3	10	2230	224	10	0.2
bis 12.0	1330	119	4	1600	192	4	12	1860	224	12	0.2
bis 14.0	1140	136	4	1370	192	4.6	14	1600	225	14	0.2
bis 16.0	1000	119	3	1200	193	5.3	16	1400	225	16	0.2

GSXLVA 4000

VHM-Schaftfräser mit kleinen Fasen

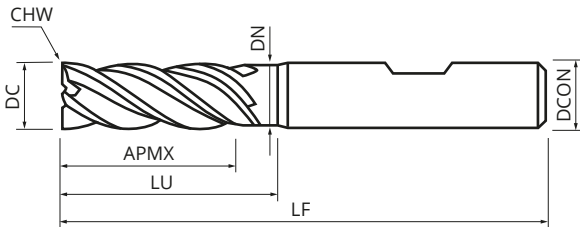

- Zur Anwendung in rostfreiem Stahl, Superlegierungen und Stahl bis HRC 45
- Kleinere Schutzfasen
- Längere Schneide und Halsfreistellung

ABMESSUNGEN

Artikelnummer (WGR. 9814)	DC mm	APMX mm	LU mm	LF mm	DCON mm	DN mm	CHW mm	ZEFP
GSXLVA 4030	3	8	18	63	6	2.7	0.1	4
GSXLVA 4040	4	11	21	63	6	3.7	0.1	4
GSXLVA 4050	5	13	21	63	6	4.7	0.1	4
GSXLVA 4060	6	15	21	63	6	5.5	0.1	4
GSXLVA 4080	8	21	26	63	8	7.5	0.1	4
GSXLVA 4100	10	26	31	72	10	9.5	0.1	4
GSXLVA 4120	12	30	37	83	12	11.5	0.1	4
GSXLVA 4160	16	40	50	100	16	15.5	0.2	4
GSXLVA 4200	20	40	54	105	20	19.5	0.2	4

SCHNITTDATEN

Bearbeitung		VOLLNUTFRÄSEN										
Material	Bemerkung	a_p (xD)	a_e (xD)	Vc m/min	3 mm/Z	4 mm/Z	6 mm/Z	8 mm/Z	10 mm/Z	12 mm/Z	16 mm/Z	20 mm/Z
Stahl	< 850 N/mm ²	1	1	130 - 150	0.012	0.020	0.030	0.040	0.050	0.060	0.070	0.100
	< 1200 N/mm ²	0.7	1	90 - 120	0.009	0.015	0.022	0.028	0.034	0.039	0.044	0.059
	< 1400 N/mm ²	0.5	1	80 - 100	0.008	0.014	0.021	0.028	0.035	0.042	0.049	0.070
Rostfreier Stahl	< 750 N/mm ²	1	1	70 - 90	0.009	0.015	0.022	0.028	0.034	0.039	0.044	0.059
	< 950 N/mm ²	0.5	1	50 - 70	0.007	0.012	0.017	0.022	0.026	0.030	0.034	0.046
Guss	< 300 HB	1	1	90 - 130	0.009	0.015	0.022	0.028	0.034	0.039	0.044	0.059
Superlegierung	Titan < 1100 N/mm ²	0.5	1	30 - 50	0.007	0.012	0.017	0.022	0.026	0.030	0.034	0.046
	HRSA < 1300 N/mm ²	0.3	1	20-30	0.005	0.009	0.012	0.017	0.022	0.025	0.030	0.040

Bearbeitung		UMFANGSFRÄSEN										
Material	Bemerkung	a_p (xD)	a_e (xD)	Vc m/min	3 mm/Z	4 mm/Z	6 mm/Z	8 mm/Z	10 mm/Z	12 mm/Z	16 mm/Z	20 mm/Z
Stahl	< 850 N/mm ²	2	0.4	150 - 180	0.013	0.026	0.039	0.052	0.065	0.078	0.104	0.130
	< 1200 N/mm ²	1.5	0.3	120 - 150	0.010	0.022	0.033	0.044	0.055	0.065	0.085	0.104
	< 1400 N/mm ²	1.2	0.3	90 - 110	0.009	0.018	0.027	0.036	0.046	0.055	0.064	0.091
Rostfreier Stahl	< 750 N/mm ²	1.5	0.4	90 - 110	0.011	0.018	0.026	0.034	0.041	0.047	0.052	0.071
	< 950 N/mm ²	1.5	0.3	60 - 80	0.009	0.016	0.023	0.030	0.036	0.041	0.047	0.063
Guss	< 300 HB	1.5	0.3	120 - 150	0.011	0.018	0.026	0.034	0.041	0.047	0.052	0.071
Superlegierung	Titan < 1100 N/mm ²	1.5	0.3	40 - 50	0.013	0.022	0.032	0.042	0.050	0.056	0.062	0.078
	HRSA < 1300 N/mm ²	1	0.3	20-30	0.005	0.012	0.025	0.035	0.040	0.050	0.055	0.060

Bearbeitung		RAMPING										
Material	Bemerkung	α °	a_e (xD)	Vc m/min	3 mm/Z	4 mm/Z	6 mm/Z	8 mm/Z	10 mm/Z	12 mm/Z	16 mm/Z	20 mm/Z
Stahl	< 850 N/mm ²	3	1	100 - 120	0.006	0.010	0.015	0.021	0.028	0.035	0.045	0.050
	< 1200 N/mm ² < 1400 N/mm ²	2	1	90 - 110	0.005	0.008	0.010	0.013	0.017	0.020	0.025	0.032
Rostfreier Stahl	< 750 N/mm ²	3	1	70 - 90	0.005	0.008	0.010	0.015	0.019	0.024	0.029	0.035
	< 950 N/mm ²	2	1	50 - 70	0.004	0.007	0.008	0.010	0.015	0.020	0.026	0.032
Guss	< 300 HB	2	0.3	100-130	0.006	0.010	0.015	0.021	0.028	0.035	0.045	0.050
Superlegierung	Titan < 1100 N/mm ²	2	0.5	40-50	0.007	0.012	0.017	0.022	0.026	0.030	0.034	0.046
	HRSA < 1300 N/mm ²	1	0.3	30-40	0.005	0.008	0.010	0.015	0.019	0.024	0.029	0.035

Bearbeitung		HELIX-FRÄSEN										
Material	Bemerkung	α °	a_e (xD)	Vc m/min	3 mm/Z	4 mm/Z	6 mm/Z	8 mm/Z	10 mm/Z	12 mm/Z	16 mm/Z	20 mm/Z
Stahl	< 850 N/mm ²	5	0.3	100 - 120	0.008	0.012	0.018	0.023	0.028	0.033	0.039	0.046
	< 1200 N/mm ² < 1400 N/mm ²	4	0.3	90 - 110	0.006	0.010	0.015	0.020	0.025	0.030	0.036	0.042
Rostfreier Stahl	< 750 N/mm ²	4	0.4	70 - 90	0.006	0.010	0.015	0.020	0.025	0.030	0.036	0.042
	< 950 N/mm ²	3	0.4	50 - 70	0.005	0.008	0.010	0.015	0.019	0.024	0.029	0.035
Guss	< 300 HB	2	0.3	100-130	0.006	0.010	0.015	0.021	0.028	0.035	0.045	0.050
Superlegierung	Titan < 1100 N/mm ²	2	0.2	40-50	0.006	0.010	0.015	0.020	0.025	0.030	0.036	0.042
	HRSA < 1300 N/mm ²	1	0.1	30-40	0.005	0.008	0.010	0.015	0.019	0.024	0.029	0.035

Bearbeitung		TROCHOIDALFRÄSEN										
Material	Bemerkung	a_p (xD)	a_e (xD)	Vc m/min	3 mm/Z	4 mm/Z	6 mm/Z	8 mm/Z	10 mm/Z	12 mm/Z	16 mm/Z	20 mm/Z
Stahl	< 850 N/mm ²	2	0.1	240 - 270	0.025	0.040	0.092	0.123	0.153	0.184	0.245	0.307
	< 1200 N/mm ²	2	0.1	190 - 210	0.022	0.035	0.079	0.106	0.132	0.156	0.204	0.250
	< 1400 N/mm ²	2	0.1	130 - 160	0.020	0.030	0.060	0.080	0.102	0.122	0.142	0.202
Rostfreier Stahl	< 750 N/mm ²	2	0.1	110-130	0.014	0.037	0.067	0.110	0.130	0.140	0.167	0.185
	< 950 N/mm ²	2	0.1	80 - 100	0.012	0.035	0.065	0.090	0.105	0.120	0.145	0.164
Guss	< 300 HB	2	0.1	120 - 150	0.011	0.018	0.077	0.103	0.128	0.152	0.198	0.243
Superlegierung	Titan < 1100 N/mm ²	2	0.1	70 - 90	0.010	0.017	0.055	0.090	0.110	0.120	0.149	0.180
	HRSA < 1300 N/mm ²	2	0.1	30-40	0.009	0.015	0.035	0.048	0.060	0.070	0.090	0.100



DCON=6-10 DCON=12

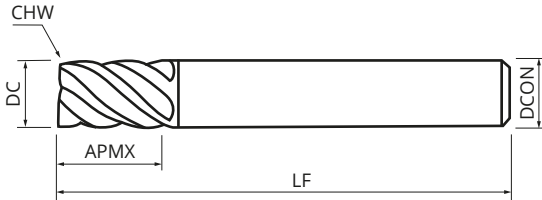

- Zur Anwendung in rostfreiem Stahl, Superlegierungen und Stahl bis HRC 45
- Spezielles Schneidendesign für HSC Bearbeitung

ABMESSUNGEN

Artikelnummer (WGR. 9810)	DC mm	APMX mm	LF mm	DCON mm	CHW mm	ZEFP
GCST 5060	6	13	57	6	0.2	5
GCST 5080	8	19	63	8	0.2	5
GCST 5100	10	14	66	10	0.3	5
GCST 5120	12	16	73	12	0.35	5

SCHNITTDATEN

Bearbeitung		UMFANGSFRÄSEN						
Material	Bemerkung	a_p (xD)	a_e (xD)	V_c m/min	6 mm/Z	8 mm/Z	10 mm/Z	12 mm/Z
Stahl	< 850 N/mm ²	1.5	0.3	130 - 160	0.040	0.045	0.050	0.060
	< 1200 N/mm ²	1.5	0.3	100 - 130	0.035	0.040	0.045	0.052
	< 1400 N/mm ²	1.5	0.3	60 - 90	0.028	0.032	0.042	0.053
Rostfreier Stahl	< 750 N/mm ²	1.5	0.3	100 - 130	0.025	0.027	0.032	0.052
	< 950 N/mm ²	1.5	0.3	60 - 90	0.020	0.021	0.025	0.038
Guss	< 300 HB	1.5	0.3	100 - 130	0.040	0.045	0.050	0.060
Superlegierung	Titan < 1100 N/mm ²	1.5	0.2	60 - 90	0.022	0.024	0.028	0.048
	HRSA < 1300 N/mm ²	1.5	0.1	30 - 50	0.016	0.018	0.022	0.037

GCMT 5000 VHM-Schaftfräser – lang

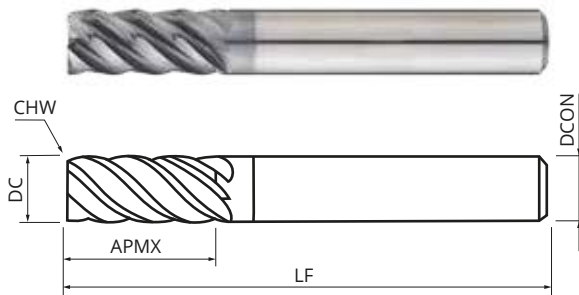

- Zur Anwendung in rostfreiem Stahl, Superlegierungen und Stahl bis HRC 45
- Verbessertes Schneidendesign für eine optimale Spanabfuhr und Stabilität beim Bearbeiten von schwer zerspanbaren Materialien

ABMESSUNGEN

Artikelnummer (WGR. 9810)	DC mm	APMX mm	LF mm	DCON mm	CHW mm	ZEFP
GCMT 5100	10	22	72	10	0.3	5
GCMT 5120	12	26	83	12	0.35	5
GCMT 5160	16	36	92	16	0.4	5

SCHNITTDATEN

Bearbeitung		UMFANGSFRÄSEN					
Material	Bemerkung	a_p (xD)	a_e (xD)	V_c m/min	10 mm/Z	12 mm/Z	16 mm/Z
Stahl	< 850 N/mm ²	1.5	0.3	130 - 160	0.050	0.060	0.075
	< 1200 N/mm ²	1.5	0.3	100 - 130	0.045	0.052	0.065
	< 1400 N/mm ²	1.5	0.3	60 - 90	0.035	0.045	0.055
Rostfreier Stahl	< 750 N/mm ²	1.5	0.3	100 - 130	0.035	0.050	0.065
	< 950 N/mm ²	1.5	0.3	60 - 90	0.025	0.038	0.045
Guss	< 300 HB	1.5	0.3	100 - 130	0.050	0.060	0.070
Superlegierung	Titan < 1100 N/mm ²	1.5	0.2	60 - 90	0.028	0.048	0.052
	HRSA < 1300 N/mm ²	1.5	0.1	30 - 50	0.022	0.037	0.040

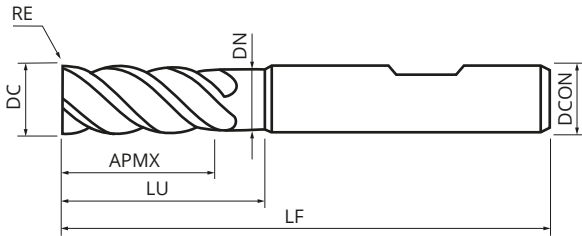

■ Zur Anwendung in Stahl bis HRC 48 und Guss

ABMESSUNGEN

Artikelnummer HB (WGR. 9814)	Artikelnummer HA (WGR. 9814)	DC mm	APMX mm	LU mm	LF mm	DCON mm	DN mm	RE mm	ZEFP
GRXFE 4030R03-HB	GRXFE 4030R03-HA	3	8	15	57	6	2.8	0.3	4
GRXFE 4030R05-HB	GRXFE 4030R05-HA	3	8	15	57	6	2.8	0.5	4
GRXFE 4040R02-HB	GRXFE 4040R02-HA	4	11	17	57	6	3.8	0.2	4
GRXFE 4040R05-HB	GRXFE 4040R05-HA	4	11	17	57	6	3.8	0.5	4
GRXFE 4040R10-HB	GRXFE 4040R10-HA	4	11	17	57	6	3.8	1	4
GRXFE 4050R05-HB	GRXFE 4050R05-HA	5	13	19	57	6	4.8	0.5	4
GRXFE 4050R10-HB	GRXFE 4050R10-HA	5	13	19	57	6	4.8	1	4
GRXFE 4060R05-HB	GRXFE 4060R05-HA	6	13	21	57	6	5.8	0.5	4
GRXFE 4060R10-HB	GRXFE 4060R10-HA	6	13	21	57	6	5.8	1	4
GRXFE 4060R20-HB	GRXFE 4060R20-HA	6	13	21	57	6	5.8	2	4
GRXFE 4080R05-HB	GRXFE 4080R05-HA	8	19	27	63	8	7.6	0.5	4
GRXFE 4080R10-HB	GRXFE 4080R10-HA	8	19	27	63	8	7.6	1	4
GRXFE 4080R15-HB	GRXFE 4080R15-HA	8	19	27	63	8	7.6	1.5	4
GRXFE 4080R20-HB	GRXFE 4080R20-HA	8	19	27	63	8	7.6	2	4
GRXFE 4100R05-HB	GRXFE 4100R05-HA	10	22	32	72	10	9.5	0.5	4
GRXFE 4100R10-HB	GRXFE 4100R10-HA	10	22	32	72	10	9.5	1	4
GRXFE 4100R15-HB	GRXFE 4100R15-HA	10	22	32	72	10	9.5	1.5	4
GRXFE 4100R20-HB	GRXFE 4100R20-HA	10	22	32	72	10	9.5	2	4
GRXFE 4120R05-HB	GRXFE 4120R05-HA	12	26	38	83	12	11.5	0.5	4
GRXFE 4120R10-HB	GRXFE 4120R10-HA	12	26	38	83	12	11.5	1	4
GRXFE 4120R15-HB	GRXFE 4120R15-HA	12	26	38	83	12	11.5	1.5	4
GRXFE 4120R20-HB	GRXFE 4120R20-HA	12	26	38	83	12	11.5	2	4
GRXFE 4120R30-HB	GRXFE 4120R30-HA	12	26	38	83	12	11.5	3	4
GRXFE 4160R05-HB	GRXFE 4160R05-HA	16	32	44	92	16	15.5	0.5	4
GRXFE 4160R10-HB	GRXFE 4160R10-HA	16	32	44	92	16	15.5	1	4
GRXFE 4160R20-HB	GRXFE 4160R20-HA	16	32	44	92	16	15.5	2	4
GRXFE 4160R30-HB	GRXFE 4160R30-HA	16	32	44	92	16	15.5	3	4
GRXFE 4160R40-HB	GRXFE 4160R40-HA	16	32	44	92	16	15.5	4	4
GRXFE 4200R05-HB	GRXFE 4200R05-HA	20	38	54	104	20	19.5	0.5	4
GRXFE 4200R10-HB	GRXFE 4200R10-HA	20	38	54	104	20	19.5	1	4
GRXFE 4200R20-HB	GRXFE 4200R20-HA	20	38	54	104	20	19.5	2	4
GRXFE 4200R30-HB	GRXFE 4200R30-HA	20	38	54	104	20	19.5	3	4

SCHNITTDATEN

Bearbeitung		VOLLNUTFRÄSEN										
Material	Bemerkung	a_p (xD)	a_e (xD)	V_c m/min	2 mm/Z	4 mm/Z	6 mm/Z	8 mm/Z	10 mm/Z	12 mm/Z	16 mm/Z	20 mm/Z
Stahl	< 850 N/mm ²	1.1	1	110 - 140	0.010	0.020	0.030	0.040	0.050	0.060	0.080	0.100
	< 1200 N/mm ²	1	1	90 - 120	0.008	0.017	0.025	0.034	0.042	0.050	0.065	0.080
	< 1400 N/mm ²	0.8	1	70 - 90	0.007	0.014	0.021	0.028	0.035	0.042	0.049	0.070
Rostfreier Stahl	< 750 N/mm ² < 950 N/mm ²											
Guss	< 300 HB	1	1	80 - 120	0.009	0.017	0.025	0.034	0.042	0.050	0.065	0.080
Superlegierung	Titan < 1100 N/mm ² HRSA < 1300 N/mm ²	0.5	1	30 - 40	0.006	0.012	0.017	0.022	0.026	0.030	0.038	0.046
Gehärteter Stahl	< 300 HB											

Bearbeitung		UMFANGSFRÄSEN										
Material	Bemerkung	a_p (xD)	a_e (xD)	V_c m/min	2 mm/Z	4 mm/Z	6 mm/Z	8 mm/Z	10 mm/Z	12 mm/Z	16 mm/Z	20 mm/Z
Stahl	< 850 N/mm ²	1.5	0.3	150 - 180	0.013	0.026	0.039	0.052	0.065	0.078	0.104	0.130
	< 1200 N/mm ²	1.5	0.3	120 - 150	0.010	0.022	0.033	0.044	0.055	0.065	0.085	0.104
	< 1400 N/mm ²	1.2	0.3	90 - 110	0.009	0.018	0.027	0.036	0.046	0.055	0.064	0.091
Rostfreier Stahl	< 750 N/mm ² < 950 N/mm ²											
Guss	< 300 HB	1.2	0.3	100 - 140	0.012	0.022	0.033	0.044	0.055	0.065	0.085	0.104
Superlegierung	Titan < 1100 N/mm ² HRSA < 1300 N/mm ²	1.2	0.3	40 - 50	0.008	0.016	0.025	0.034	0.044	0.052	0.060	0.070
Gehärteter Stahl	< 300 HB	1.2	0.3	40 - 50	0.005	0.012	0.018	0.025	0.033	0.040	0.048	0.055

Bearbeitung		RAMPING										
Material	Bemerkung	α °	a_e (xD)	V_c m/min	2 mm/Z	4 mm/Z	6 mm/Z	8 mm/Z	10 mm/Z	12 mm/Z	16 mm/Z	20 mm/Z
Stahl	< 850 N/mm ²	2	1	90 - 110	0.006	0.012	0.021	0.031	0.038	0.047	0.051	0.06
	< 1200 N/mm ²	1.5	1	80 - 100	0.005	0.011	0.018	0.026	0.032	0.039	0.044	0.053
	< 1400 N/mm ²	1.5	1	50 - 70	0.005	0.010	0.016	0.023	0.029	0.035	0.038	0.048
Rostfreier Stahl	< 750 N/mm ² < 950 N/mm ²											
Guss	< 300 HB	2	1	100 - 120	0.006	0.012	0.024	0.031	0.042	0.050	0.058	0.067
Superlegierung	Titan < 1100 N/mm ² HRSA < 1300 N/mm ²	1.5	1	50 - 70	0.005	0.011	0.018	0.026	0.032	0.028	0.043	0.052
Gehärteter Stahl	< 300 HB	1	1	50 - 60	0.005	0.008	0.016	0.021	0.060	0.030	0.032	0.041

Bearbeitung		HELIX-FRÄSEN										
Material	Bemerkung	α °	a_e (xD)	V_c m/min	2 mm/Z	4 mm/Z	6 mm/Z	8 mm/Z	10 mm/Z	12 mm/Z	16 mm/Z	20 mm/Z
Stahl	< 850 N/mm ²	2	0.3	110 - 130	0.012	0.025	0.035	0.047	0.060	0.074	0.081	0.094
	< 1200 N/mm ²	1.5	0.3	90 - 110	0.010	0.023	0.030	0.041	0.051	0.060	0.068	0.084
	< 1400 N/mm ²	1.5	0.3	70 - 90	0.009	0.020	0.026	0.037	0.047	0.055	0.060	0.075
Rostfreier Stahl	< 750 N/mm ² < 950 N/mm ²											
Guss	< 300 HB	2	0.3	100 - 120	0.012	0.028	0.038	0.050	0.065	0.077	0.085	0.095
Superlegierung	Titan < 1100 N/mm ² HRSA < 1300 N/mm ²	1.5	0.3	50 - 70	0.008	0.011	0.018	0.023	0.029	0.035	0.036	0.046
Gehärteter Stahl	< 300 HB	1	0.3	50 - 60	0.008	0.018	0.023	0.031	0.039	0.047	0.052	0.065

Bearbeitung		TROCHOIDALFRÄSEN										
Material	Bemerkung	a_p (xD)	a_e (xD)	V_c m/min	2 mm/Z	4 mm/Z	6 mm/Z	8 mm/Z	10 mm/Z	12 mm/Z	16 mm/Z	20 mm/Z
Stahl	< 850 N/mm ²	2	0.1	240 - 270	0.031	0.061	0.092	0.123	0.153	0.184	0.245	0.307
	< 1200 N/mm ²	2	0.1	190 - 210	0.024	0.053	0.079	0.106	0.132	0.156	0.204	0.250
	< 1400 N/mm ²	2	0.1	130 - 160	0.02	0.040	0.060	0.080	0.102	0.122	0.142	0.202
Rostfreier Stahl	< 750 N/mm ² < 950 N/mm ²											
Guss	< 300 HB	2	0.1	180 - 210	0.028	0.051	0.077	0.103	0.128	0.152	0.198	0.243
Superlegierung	Titan < 1100 N/mm ² HRSA < 1300 N/mm ²	2	0.1	60 - 80	0.018	0.036	0.056	0.077	0.099	0.117	0.135	0.158
Gehärteter Stahl	< 300 HB	1.5	0.1	50 - 60	0.011	0.026	0.040	0.055	0.073	0.088	0.106	0.121

GCRESN 4000 VHM-Torusfräser

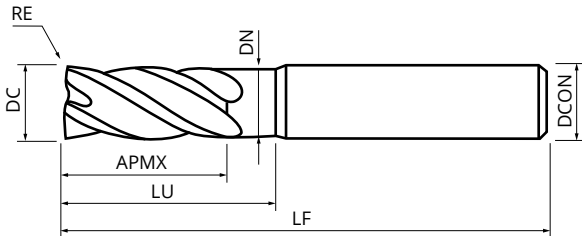

- Zur Anwendung in Stahl, gehärtetem Stahl und Kupfer

DC	RE	Toleranzen	
1 - 6	R0.2 - R2	0/-0.015 DC-TOL	±0.01 RE
8 - 20	R0.2 - R2	0/-0.02 DC-TOL	±0.01 RE

ABMESSUNGEN

Artikelnummer (WGR. 9818)	DC mm	APMX mm	LU mm	LF mm	DCON mm	DN mm	RE mm	ZEFP
GCRESN 4030R02	3	4.5	9	50	6	2.9	0.2	4
GCRESN 4030R05	3	4.5	9	50	6	2.9	0.5	4
GCRESN 4040R02	4	6	12	50	6	3.9	0.2	4
GCRESN 4040R05	4	6	12	50	6	3.9	0.5	4
GCRESN 4040R10	4	6	12	50	6	3.9	1.0	4
GCRESN 4050R02	5	7.5	15	50	6	4.8	0.2	4
GCRESN 4050R05	5	7.5	15	50	6	4.8	0.5	4
GCRESN 4050R10	5	7.5	15	50	6	4.8	1.0	4
GCRESN 4060R02	6	9	18	50	6	5.7	0.2	4
GCRESN 4060R03	6	9	18	50	6	5.7	0.3	4
GCRESN 4060R05	6	9	18	50	6	5.7	0.5	4
GCRESN 4060R10	6	9	18	50	6	5.7	1.0	4
GCRESN 4060R15	6	9	18	50	6	5.7	1.5	4
GCRESN 4080R02	8	12	24	60	8	7.6	0.2	4
GCRESN 4080R03	8	12	24	60	8	7.6	0.3	4
GCRESN 4080R05	8	12	24	60	8	7.6	0.5	4
GCRESN 4080R10	8	12	24	60	8	7.6	1.0	4
GCRESN 4080R20	8	12	24	60	8	7.6	2.0	4
GCRESN 4100R03	10	15	30	70	10	9.5	0.3	4
GCRESN 4100R05	10	15	30	70	10	9.5	0.5	4
GCRESN 4100R10	10	15	30	70	10	9.5	1.0	4
GCRESN 4100R15	10	15	30	70	10	9.5	1.5	4
GCRESN 4100R20	10	15	30	70	10	9.5	2.0	4
GCRESN 4120R03	12	20	36	80	12	11.5	0.3	4

ABMESSUNGEN

Artikelnummer (WGR. 9818)	DC mm	APMX mm	LU mm	LF mm	DCON mm	DN mm	RE mm	ZEFP
GCRESN 4120R05	12	20	36	80	12	11.5	0.5	4
GCRESN 4120R10	12	20	36	80	12	11.5	1.0	4
GCRESN 4120R15	12	20	36	80	12	11.5	1.5	4
GCRESN 4120R20	12	20	36	80	12	11.5	2.0	4
GCRESN 4160R05	16	24	48	93	16	15	0.5	4
GCRESN 4160R10	16	24	48	93	16	15	1.0	4
GCRESN 4160R20	16	24	48	93	16	15	2.0	4
GCRESN 4200R05	20	30	60	105	20	19	0.5	4
GCRESN 4200R10	20	30	60	105	20	19	1.0	4
GCRESN 4200R20	20	30	60	105	20	19	2.0	4

SCHNITTDATEN

Material	Kohlenstoffstahl											
	HB 180 - 250											
	Schruppen				Schichten 3D				Schichten Planfräsen			
DC mm	n min ⁻¹	Vf mm/min	a _p mm	a _e mm	n min ⁻¹	Vf mm/min	a _p mm	a _e mm	n min ⁻¹	Vf mm/min	a _p mm	a _e mm
3	19639	2150	4.5	0.3	27601	8280	0.033	0.067	17516	5255	0.057	1.2
4	14729	2200	6	0.4	20701	7866	0.033	0.067	13137	4992	0.057	1.6
5	11783	2200	5	0.5	16561	9274	0.033	0.067	10510	5885	0.057	2
6	9820	2553	6	0.6	13800	8832	0.092	0.183	8758	5605	0.155	2.4
8	7365	2504	8	0.8	10350	8901	0.041	0.082	6568	5649	0.069	3.2
10	5892	2828	10	1	8280	8943	0.106	0.212	5255	5675	0.179	4
12	4910	2650	18	1.2	6900	8556	0.041	0.082	4379	5430	0.069	4.8
16	3682	2651	24	1.6	5175	8280	0.106	0.212	3284	5255	0.179	6.4
20	2946	2357	30	2	4140	7452	0.106	0.212	2627	4729	0.179	8

Material	Stahl											
	HRC 25 - 34											
	Schruppen				Schichten 3D				Schichten Planfräsen			
DC mm	n min ⁻¹	Vf mm/min	a _p mm	a _e mm	n min ⁻¹	Vf mm/min	a _p mm	a _e mm	n min ⁻¹	Vf mm/min	a _p mm	a _e mm
3	17516	1611	4.05	0.252	21231	5096	0.033	0.067	15393	3694	0.057	1.2
4	13137	1734	5.4	0.336	15924	5414	0.033	0.067	11545	3925	0.057	1.6
5	10510	1810	4.5	0.42	12739	5096	0.033	0.067	9236	3694	0.057	2
6	8758	1927	5.4	0.504	10616	5096	0.092	0.183	7696	3694	0.155	2.4
8	6568	1708	7.2	0.672	7962	5255	0.041	0.082	5772	3810	0.069	3.2
10	5255	2207	9	0.84	6369	5605	0.106	0.212	4618	4064	0.179	4
12	4379	2250	13.2	1.008	5308	5945	0.041	0.082	3848	4310	0.069	4.8
16	3284	2233	17.6	1.344	3981	4777	0.106	0.212	2886	3463	0.179	6.4
20	2627	1944	22	1.68	3185	4204	0.106	0.212	2309	3048	0.179	8

SCHNITTDATEN

Material	Vorgehärteter Stahl											
	HRC 35 – 45											
	Schruppen				Schichten 3D				Schichten Planfräsen			
DC mm	n min ⁻¹	Vf mm/min	a _p mm	a _e mm	n min ⁻¹	Vf mm/min	a _p mm	a _e mm	n min ⁻¹	Vf mm/min	a _p mm	a _e mm
3	12208	1123	3.6	0.192	18047	3248	0.033	0.067	12739	2293	0.057	1.2
4	9156	1099	4.8	0.256	13535	3411	0.033	0.067	9554	2408	0.057	1.6
5	7325	1025	4	0.32	10828	3032	0.033	0.067	7643	2140	0.057	2
6	6104	1099	4.8	0.384	9023	3068	0.092	0.183	6369	2166	0.155	2.4
8	4578	1007	6.4	0.512	6768	2842	0.041	0.082	4777	2006	0.069	3.2
10	3662	1465	8	0.64	5414	3898	0.106	0.212	3822	2752	0.179	4
12	3850	1850	9.6	0.768	4512	3970	0.041	0.082	3185	2803	0.069	4.8
16	3850	2079	16	1.024	3384	3384	0.106	0.212	2389	2389	0.179	6.4
20	3850	2233	20	1.28	2707	2924	0.106	0.212	1911	2064	0.179	8

Material	Gehärteter Stahl											
	HRC 46 – 55											
	Schruppen				Schichten 3D				Schichten Planfräsen			
DC mm	n min ⁻¹	Vf mm/min	a _p mm	a _e mm	n min ⁻¹	Vf mm/min	a _p mm	a _e mm	n min ⁻¹	Vf mm/min	a _p mm	a _e mm
3	5300	590	2.925	0.168	15393	2155	0.033	0.067	9023	1263	0.057	1.2
4	5300	590	3.9	0.224	11545	2540	0.033	0.067	6768	1489	0.057	1.6
5	4800	490	3.25	0.28	9236	2217	0.033	0.067	5414	1299	0.057	2
6	4777	764	3.9	0.336	7696	2155	0.092	0.183	4512	1263	0.155	2.4
8	3583	659	5.2	0.448	5772	2032	0.041	0.082	3384	1191	0.069	3.2
10	2866	1009	6.5	0.56	4618	2217	0.106	0.212	2707	1299	0.179	4
12	2389	1003	9.6	0.672	3848	2309	0.041	0.082	2256	1354	0.069	4.8
16	1791	752	16	0.896	2886	2136	0.106	0.212	1692	1252	0.179	6.4
20	1433	659	20	1.12	2309	1847	0.106	0.212	1354	1083	0.179	8

SCHNITTDATEN

Material	Gehärteter Stahl											
	HRC 56 - 60											
	Schruppen				Schichten 3D				Schichten Planfräsen			
DC mm	n min ⁻¹	Vf mm/min	a _p mm	a _e mm	n min ⁻¹	Vf mm/min	a _p mm	a _e mm	n min ⁻¹	Vf mm/min	a _p mm	a _e mm
3	5300	500	2.7	0.12	11677	1401	0.033	0.067	3715	446	0.057	1.2
4	5300	500	3.6	0.16	8758	1576	0.033	0.067	2787	502	0.057	1.6
5	4800	450	3	0.2	7006	1401	0.033	0.067	2229	446	0.057	2
6	3450	386	3.6	0.24	5839	1425	0.092	0.183	1858	453	0.155	2.4
8	2588	342	4.8	0.32	4379	1226	0.041	0.082	1393	390	0.069	3.2
10	2070	233	6	0.4	3503	1261	0.106	0.212	1115	401	0.179	4
12	1730	850	9.6	0.48	2919	1168	0.041	0.082	929	372	0.069	4.8
16	1294	518	9.6	0.64	2189	1051	0.106	0.212	697	334	0.179	6.4
20	1035	455	12	0.8	1752	981	0.106	0.212	557	312	0.179	8

Material	Kupfer											
	Schruppen				Schichten 3D				Schichten Planfräsen			
DC mm	n min ⁻¹	Vf mm/min	a _p mm	a _e mm	n min ⁻¹	Vf mm/min	a _p mm	a _e mm	n min ⁻¹	Vf mm/min	a _p mm	a _e mm
3	21000	2300	5.4	0.168	30255	5446	0.033	0.067	18577	3344	0.057	1.05
4	15600	2304	7.2	0.192	22691	2304	0.033	0.067	13933	2304	0.057	1.4
5	12400	2350	6	0.24	18153	2350	0.033	0.067	11146	2350	0.057	1.75
6	10400	2650	7.2	0.288	15127	2650	0.092	0.183	9289	2650	0.155	2.1
8	10400	2650	9.6	0.384	11346	2650	0.041	0.082	6967	2650	0.069	2.8
10	6210	2484	12	0.48	9076	3631	0.106	0.212	5573	2229	0.179	3.5
12	5175	2484	14.4	0.576	7564	3631	0.041	0.082	4644	2229	0.069	4.2
16	3881	3105	19.2	0.768	5673	4538	0.106	0.212	3483	2787	0.179	5.6
20	3105	2732	24	0.96	4538	3994	0.106	0.212	2787	2452	0.179	7

GCRELN 4000

VHM-Torusfräser 5xD

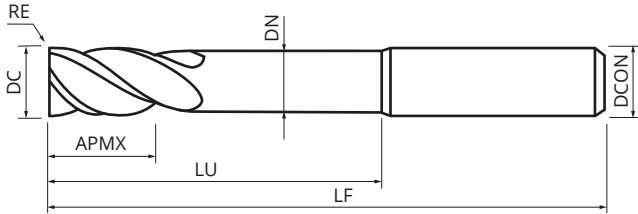

- Zur Anwendung in Stahl, gehärtetem Stahl und Kupfer

DC	RE	Toleranzen	
1 - 6	R0.2 - R2	0/-0.015 DC-TOL	±0.01 RE
8 - 20	R0.2 - R2	0/-0.02 DC-TOL	±0.01 RE

ABMESSUNGEN

Artikelnummer (WGR. 9818)	DC mm	APMX mm	LU mm	LF mm	DCON mm	DN mm	RE mm	ZEFP
GCRELN 4030R02	3	4.5	15	56	6	2.9	0.2	4
GCRELN 4030R05	3	4.5	15	56	6	2.9	0.5	4
GCRELN 4040R02	4	6	20	58	6	3.9	0.2	4
GCRELN 4040R05	4	6	20	58	6	3.9	0.5	4
GCRELN 4040R10	4	6	20	58	6	3.9	1.0	4
GCRELN 4050R02	5	7.5	25	60	6	4.8	0.2	4
GCRELN 4050R05	5	7.5	25	60	6	4.8	0.5	4
GCRELN 4050R10	5	7.5	25	60	6	4.8	1.0	4
GCRELN 4060R03	6	9	30	62	6	5.7	0.3	4
GCRELN 4060R05	6	9	30	62	6	5.7	0.5	4
GCRELN 4060R10	6	9	30	62	6	5.7	1.0	4
GCRELN 4060R15	6	9	30	62	6	5.7	1.5	4
GCRELN 4080R03	8	12	40	71	8	7.6	0.3	4
GCRELN 4080R05	8	12	40	71	8	7.6	0.5	4
GCRELN 4080R10	8	12	40	71	8	7.6	1.0	4
GCRELN 4080R20	8	12	40	71	8	7.6	2.0	4
GCRELN 4100R03	10	15	50	90	10	9.5	0.3	4
GCRELN 4100R05	10	15	50	90	10	9.5	0.5	4
GCRELN 4100R10	10	15	50	90	10	9.5	1.0	4
GCRELN 4100R15	10	15	50	90	10	9.5	1.5	4
GCRELN 4100R20	10	15	50	90	10	9.5	2.0	4
GCRELN 4120R03	12	18	60	100	12	11.5	0.3	4
GCRELN 4120R05	12	18	60	100	12	11.5	0.5	4
GCRELN 4120R10	12	18	60	100	12	11.5	1.0	4
GCRELN 4120R15	12	18	60	100	12	11.5	1.5	4
GCRELN 4120R20	12	18	60	100	12	11.5	2.0	4
GCRELN 4160R05	16	24	80	122	16	15	0.5	4
GCRELN 4160R10	16	24	80	122	16	15	1.0	4
GCRELN 4160R20	16	24	80	122	16	15	2.0	4

SCHNITTDATEN

Material	Kohlenstoffstahl											
	HB 180 - 250											
	Schruppen				Schichten 3D				Schichten Planfräsen			
DC mm	n min ⁻¹	Vf mm/min	a _p mm	a _e mm	n min ⁻¹	Vf mm/min	a _p mm	a _e mm	n min ⁻¹	Vf mm/min	a _p mm	a _e mm
3	16690	2150	4.5	0.27	23460	7040	0.033	0.07	15760	4730	0.051	1.2
4	11170	2200	6.0	0.36	17600	6690	0.053	0.11	11820	4490	0.080	1.6
5	10020	2200	5.0	0.45	14080	7880	0.053	0.11	9460	5300	0.114	2.0
6	8350	2170	6.0	0.54	11730	7510	0.053	0.11	7880	5040	0.062	2.4
8	6260	2130	8.0	0.72	8800	7570	0.075	0.15	5910	5080	0.161	3.2
10	5010	2400	10.0	0.90	7040	7600	0.075	0.15	4730	5110	0.062	4.0
12	4170	2650	18.0	1.08	5870	7270	0.075	0.15	3940	4890	0.161	4.8
16	3130	2250	24.0	1.44	4400	7040	0.075	0.15	2960	4730	0.080	6.4
20	2500	2000	30.0	1.80	3520	6330	0.075	0.15	2360	4260	0.161	8.0

Material	Stahl											
	HRC 25 - 34											
	Schruppen				Schichten 3D				Schichten Planfräsen			
DC mm	n min ⁻¹	Vf mm/min	a _p mm	a _e mm	n min ⁻¹	Vf mm/min	a _p mm	a _e mm	n min ⁻¹	Vf mm/min	a _p mm	a _e mm
3	15760	1610	4.1	0.227	19110	4590	0.033	0.07	13850	3320	0.051	1.2
4	11820	1730	5.4	0.302	14330	4870	0.053	0.11	10390	3530	0.080	1.6
5	9460	1810	4.5	0.378	11460	4590	0.053	0.11	8310	3320	0.114	2.0
6	7880	1730	5.4	0.454	9550	4590	0.053	0.11	6930	3320	0.062	2.4
8	5910	1540	7.2	0.605	7170	4730	0.075	0.15	5200	3430	0.161	3.2
10	4730	1990	9.0	0.756	5730	5040	0.075	0.15	4160	3660	0.062	4.0
12	3940	2250	13.2	0.907	4780	5350	0.075	0.15	3460	3880	0.161	4.8
16	2960	2010	17.6	1.210	3580	4300	0.075	0.15	2600	3120	0.080	6.4
20	2360	1750	22.0	1.512	2870	3780	0.075	0.15	2080	2740	0.161	8.0

SCHNITTDATEN

Material	Vorgehärteter Stahl											
	HRC 35 – 45											
	Schruppen				Schichten 3D				Schichten Planfräsen			
DC mm	n min ⁻¹	Vf mm/min	a _p mm	a _e mm	n min ⁻¹	Vf mm/min	a _p mm	a _e mm	n min ⁻¹	Vf mm/min	a _p mm	a _e mm
3	11600	1070	3.6	0.173	16240	2920	0.033	0.07	11460	2060	0.045	1.2
4	8700	1040	4.8	0.230	12180	3070	0.053	0.11	8600	2170	0.072	1.6
5	6960	970	4.0	0.288	9750	2730	0.053	0.11	6880	1930	0.101	2.0
6	5800	1040	4.8	0.346	8120	2760	0.053	0.11	5730	1950	0.055	2.4
8	4350	960	6.4	0.461	6090	2560	0.075	0.15	4300	1810	0.143	3.2
10	3480	1390	8.0	0.576	4870	3510	0.075	0.15	3440	2480	0.055	4.0
12	3850	1850	9.6	0.691	4060	3570	0.075	0.15	2870	2520	0.143	4.8
16	2170	1170	16.0	0.922	3050	3050	0.075	0.15	2150	2150	0.072	6.4
20	1740	1010	20.0	1.152	2440	2630	0.075	0.15	1720	1860	0.143	8.0

Material	Gehärteter Stahl											
	HRC 46 – 55											
	Schruppen				Schichten 3D				Schichten Planfräsen			
DC mm	n min ⁻¹	Vf mm/min	a _p mm	a _e mm	n min ⁻¹	Vf mm/min	a _p mm	a _e mm	n min ⁻¹	Vf mm/min	a _p mm	a _e mm
3	4510	590	2.9	0.151	13850	1940	0.033	0.07	8120	1140	0.045	1.2
4	4080	540	3.9	0.202	10390	2290	0.053	0.11	6090	1340	0.072	1.6
5	4080	490	3.3	0.252	8310	1990	0.053	0.11	4870	1170	0.101	2.0
6	4060	650	3.9	0.302	6930	1940	0.053	0.11	4060	1140	0.055	2.4
8	3050	560	5.2	0.403	5200	1830	0.075	0.15	3050	1070	0.143	3.2
10	2440	860	6.5	0.504	4160	1990	0.075	0.15	2440	1170	0.055	4.0
12	2030	850	9.6	0.605	3460	2080	0.075	0.15	2030	1220	0.143	4.8
16	1520	640	16.0	0.806	2600	1920	0.075	0.15	1520	1130	0.072	6.4
20	1220	560	20.0	1.008	2080	1660	0.075	0.15	1220	970	0.143	8.0

SCHNITTDATEN

Material	Gehärteter Stahl											
	HRC 56 - 60											
	Schruppen				Schichten 3D				Schichten Planfräsen			
DC mm	n min ⁻¹	Vf mm/min	a _p mm	a _e mm	n min ⁻¹	Vf mm/min	a _p mm	a _e mm	n min ⁻¹	Vf mm/min	a _p mm	a _e mm
3	4510	500	2.7	0.108	9340	1120	0.033	0.067	3340	400	0.040	1.2
4	4080	500	3.6	0.144	7010	1260	0.053	0.106	2510	450	0.063	1.6
5	4080	450	3.0	0.180	5610	1120	0.053	0.106	2010	400	0.089	2.0
6	2930	330	3.6	0.216	4670	1140	0.053	0.106	1670	410	0.048	2.4
8	2200	290	4.8	0.288	3500	980	0.075	0.150	1250	350	0.125	3.2
10	1760	200	6.0	0.360	2800	1010	0.075	0.150	1000	360	0.048	4.0
12	1470	850	9.6	0.432	2340	930	0.075	0.150	840	330	0.125	4.8
16	1100	440	9.6	0.576	1750	840	0.075	0.150	630	300	0.063	6.4
20	880	390	12.0	0.720	1400	780	0.075	0.150	500	280	0.125	8.0

Material	Kupfer											
	Schruppen				Schichten 3D				Schichten Planfräsen			
DC mm	n min ⁻¹	Vf mm/min	a _p mm	a _e mm	n min ⁻¹	Vf mm/min	a _p mm	a _e mm	n min ⁻¹	Vf mm/min	a _p mm	a _e mm
3	17850	2300	5.4	0.151	25720	4630	0.033	0.07	18580	3340	0.057	1.1
4	13260	2300	7.2	0.173	19290	2300	0.053	0.11	13930	2300	0.089	1.4
5	10540	2350	6.0	0.216	15430	2350	0.053	0.11	11150	2350	0.126	1.8
6	8840	2650	7.2	0.259	12860	2650	0.053	0.11	9290	2650	0.069	2.1
8	6630	2650	9.6	0.346	9640	2650	0.075	0.15	6970	2650	0.179	2.8
10	5280	2110	12.0	0.432	7710	3090	0.075	0.15	5570	2230	0.069	3.5
12	4400	2110	14.4	0.518	6430	3090	0.075	0.15	4640	2230	0.179	4.2
16	3300	2640	19.2	0.691	4820	3860	0.075	0.15	3480	2790	0.089	5.6
20	2640	2320	24.0	0.864	3860	3390	0.075	0.15	2790	2450	0.179	7.0



0/-0.005

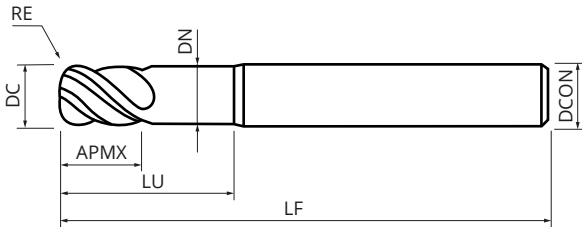

- Zur Anwendung in Stahl bis HRC 55, rostfreiem Stahl, Superlegierungen sowie Kupfer

DC	RE	Toleranzen	
2 - 6	R0,3 - R1	0/-0.02 DC-TOL	±0.01 RE
8 - 12	R0,5 - R3	-0.01/ -0.03 DC-TOL	±0.015 RE

ABMESSUNGEN

Artikelnummer (WGR. 7780)	DC mm	APMX mm	LU mm	LF mm	DCON mm	DN mm	RE mm	ZEFP
GCR 4020-05-06	2	2	6	45	4	1.91	0.5	4
GCR 4030-05-12	3	3	12	60	6	2.92	0.5	4
GCR 4040-03-08	4	4	8	50	4	3.82	0.3	4
GCR 4040-05-12	4	4	12	50	6	3.82	0.5	4
GCR 4040-05-16	4	4	16	60	6	3.82	0.5	4
GCR 4060-05-18	6	6	18	60	6	5.82	0.5	4
GCR 4060-05-24L	6	6	24	90	6	5.82	0.5	4
GCR 4060-10-18	6	6	18	60	6	5.82	1.0	4
GCR 4060-10-24L	6	6	24	90	6	5.82	1.0	4
GCR 4080-05-26	8	8	26	70	8	7.82	0.5	4
GCR 4080-05-32L	8	8	32	100	8	7.82	0.5	4
GCR 4080-10-26	8	8	26	70	8	7.82	1.0	4
GCR 4080-10-32L	8	8	32	100	8	7.82	1.0	4
GCR 4080-15-24	8	8	24	70	8	7.82	1.5	4
GCR 4080-15-32L	8	8	32	100	8	7.82	1.5	4
GCR 4080-20-24	8	8	24	70	8	7.82	2.0	4
GCR 4080-20-32L	8	8	32	100	8	7.82	2.0	4
GCR 4100-05-30	10	10	30	80	10	9.82	0.5	4
GCR 4100-05-30L	10	10	30	120	10	9.82	0.5	4
GCR 4100-10-30	10	10	30	80	10	9.82	1.0	4
GCR 4100-10-40L	10	10	40	120	10	9.82	1.0	4
GCR 4100-15-30	10	10	30	80	10	9.82	1.5	4
GCR 4100-15-40L	10	10	40	120	10	9.82	1.5	4
GCR 4100-20-30	10	10	30	80	10	9.82	2.0	4
GCR 4100-20-40L	10	10	40	120	10	9.82	2.0	4
GCR 4100-30-30	10	10	30	80	10	9.82	3.0	4
GCR 4100-30-40L	10	10	40	120	10	9.82	3.0	4
GCR 4120-05-36	12	12	36	100	12	11.82	0.5	4
GCR 4120-05-48L	12	12	48	120	12	11.82	0.5	4
GCR 4120-10-36	12	12	36	100	12	11.82	1.0	4
GCR 4120-10-48L	12	12	48	120	12	11.82	1.0	4
GCR 4120-20-36	12	12	36	100	12	11.82	2.0	4
GCR 4120-20-48L	12	12	48	120	12	11.82	2.0	4
GCR 4120-30-36	12	12	36	100	12	11.82	3.0	4
GCR 4120-30-48L	12	12	48	120	12	11.82	3.0	4

SCHNITTDATEN

Material			Stahl							
			~ HRC 20 / ~ 800 N/mm ²							
			Schruppen				Schlichten			
Artikel	DC mm	RE mm	n min ⁻¹	Vf mm/min	a _p mm	a _e mm	n min ⁻¹	Vf mm/min	a _p mm	a _e mm
4020-05-06	2	0.5	30000	7200	0.08	0.8	30000	1720	0.1	0.06
4030-05-12	3	0.5	20000	8400	0.09	1.2	20000	1890	0.1	0.09
4040-03-08	4	0.3	15000	9600	0.09	1.6	15000	1050	0.1	0.07
4040-05-12 / 16	4	0.5	15000	9600	0.1	1.6	15000	1360	0.1	0.09
4060-05-18 / 24L	6	0.5	10000	12000	0.14	2.4	10000	1150	0.2	0.12
4060-10-18 / 24L	6	1.0	10000	12000	0.15	2.4	10000	1630	0.2	0.16
4080-05-26 / 32L	8	0.5	7500	12000	0.18	2.64	7500	990	0.2	0.13
4080-10-26 / 32L	8	1.0	7500	12000	0.2	2.72	7500	1410	0.2	0.19
4080-15-24 / 32L	8	1.5	7500	12000	0.22	2.8	7500	1650	0.2	0.23
4080-20-24 / 32L	8	2.0	7500	12000	0.24	2.88	7500	1990	0.2	0.27
4100-05-30 / 30L	10	0.5	6000	12000	0.22	3.04	6000	940	0.2	0.16
4100-10-30 / 40L	10	1.0	6000	12000	0.24	3.28	6000	1330	0.2	0.22
4100-15-30 / 40L	10	1.5	6000	12000	0.25	3.36	6000	1580	0.2	0.26
4100-20-30 / 40L	10	2.0	6000	12000	0.26	3.44	6000	1890	0.2	0.32
4100-30-30 / 40L	10	3.0	6000	12000	0.27	3.52	6000	2050	0.2	0.35
4120-05-36 / 48L	12	0.5	5000	12000	0.26	3.66	5000	1200	0.2	0.32
4120-10-36 / 48L	12	1.0	5000	12000	0.26	3.7	5000	1580	0.2	0.33
4120-20-36 / 48L	12	2.0	5000	12000	0.28	3.76	5000	1760	0.2	0.35
4120-30-36 / 48L	12	3.0	5000	12000	0.3	4	5000	1950	0.2	0.37

Material			Legierter Stahl							
			HRC 20 ~ 35 / 800 ~ 1100 N/mm ²							
			Schruppen				Schlichten			
Artikel	DC mm	RE mm	n min ⁻¹	Vf mm/min	a _p mm	a _e mm	n min ⁻¹	Vf mm/min	a _p mm	a _e mm
4020-05-06	2	0.5	30000	7200	0.04	0.66	30000	1510	0.05	0.05
4030-05-12	3	0.5	20000	7200	0.04	1.08	20000	1660	0.05	0.08
4040-03-08	4	0.3	15000	7200	0.05	1.32	15000	910	0.05	0.06
4040-05-12 / 16	4	0.5	15000	7200	0.05	1.35	15000	1180	0.05	0.08
4060-05-18 / 24L	6	0.5	10000	7200	0.07	1.98	10000	990	0.1	0.1
4060-10-18 / 24L	6	1.0	10000	7200	0.07	2.16	10000	1400	0.1	0.14
4080-05-26 / 32L	8	0.5	7500	7200	0.08	2.61	7500	860	0.1	0.11
4080-10-26 / 32L	8	1.0	7500	7200	0.09	2.74	7500	1210	0.1	0.16
4080-15-24 / 32L	8	1.5	7500	7200	0.09	2.74	7500	1530	0.1	0.2
4080-20-24 / 32L	8	2.0	7500	7200	0.1	2.79	7500	1720	0.1	0.23
4100-05-30 / 30L	10	0.5	5000	5400	0.14	2.88	5000	660	0.1	0.13
4100-10-30 / 40L	10	1.0	5000	5400	0.14	2.97	5000	940	0.1	0.19
4100-15-30 / 40L	10	1.5	5000	5400	0.14	3.01	5000	1050	0.1	0.24
4100-20-30 / 40L	10	2.0	5000	5400	0.14	3.06	5000	1340	0.1	0.27
4100-30-30 / 40L	10	3.0	5000	5400	0.14	3.08	5000	1560	0.1	0.3
4120-05-36 / 48L	12	0.5	3000	4320	0.18	3.15	3000	660	0.1	0.24
4120-10-36 / 48L	12	1.0	3000	4320	0.18	3.15	3000	720	0.1	0.27
4120-20-36 / 48L	12	2.0	3000	4320	0.18	3.15	3000	870	0.1	0.29
4120-30-36 / 48L	12	3.0	3000	4320	0.17	3.15	3000	1030	0.1	0.33

SCHNITTDATEN

Material			Rostfreier Stahl							
			225 ~ 325 HB							
			Schruppen				Schlichten			
Artikel	DC mm	RE mm	n min ⁻¹	Vf mm/min	a _p mm	a _e mm	n min ⁻¹	Vf mm/min	a _p mm	a _e mm
4020-05-06	2	0.5	30000	7200	0.04	0.66	30000	1510	0.05	0.05
4030-05-12	3	0.5	20000	7200	0.04	1.08	20000	1660	0.05	0.08
4040-03-08	4	0.3	15000	7200	0.05	1.32	15000	910	0.05	0.06
4040-05-12 / 16	4	0.5	15000	7200	0.05	1.35	15000	1180	0.05	0.08
4060-05-18 / 24L	6	0.5	10000	7200	0.07	1.98	10000	990	0.1	0.1
4060-10-18 / 24L	6	1.0	10000	7200	0.07	2.16	10000	1400	0.1	0.14
4080-05-26 / 32L	8	0.5	7500	7200	0.08	2.61	7500	860	0.1	0.11
4080-10-26 / 32L	8	1.0	7500	7200	0.09	2.7	7500	1210	0.1	0.16
4080-15-24 / 32L	8	1.5	7500	7200	0.1	2.79	7500	1530	0.1	0.2
4080-20-24 / 32L	8	2.0	5000	5400	0.14	2.82	7500	1720	0.1	0.23
4100-05-30 / 30L	10	0.5	5000	5400	0.14	2.88	5000	660	0.1	0.13
4100-10-30 / 40L	10	1.0	5000	5400	0.14	2.97	5000	940	0.1	0.19
4100-15-30 / 40L	10	1.5	5000	5400	0.14	3.01	5000	1050	0.1	0.24
4100-20-30 / 40L	10	2.0	5000	5400	0.14	3.06	5000	1340	0.1	0.27
4100-30-30 / 40L	10	3.0	5000	5400	0.14	3.09	5000	1560	0.1	0.3
4120-05-36 / 48L	12	0.5	3000	4320	0.18	2.9	3000	660	0.1	0.24
4120-10-36 / 48L	12	1.0	3000	4320	0.18	2.96	3000	720	0.1	0.27
4120-20-36 / 48L	12	2.0	3000	4320	0.18	3.06	3000	870	0.1	0.29
4120-30-36 / 48L	12	3.0	3000	4320	0.18	3.15	3000	1030	0.1	0.33

Material			Superlegierung							
			Titan							
			Schruppen				Schlichten			
Artikel	DC mm	RE mm	n min ⁻¹	Vf mm/min	a _p mm	a _e mm	n min ⁻¹	Vf mm/min	a _p mm	a _e mm
4020-05-06	2	0.5	21420	4010	0.03	0.33	21420	840	0.04	0.03
4030-05-12	3	0.5	14280	4010	0.03	0.54	14280	920	0.04	0.04
4040-03-08	4	0.3	10710	4010	0.04	0.66	10710	510	0.04	0.03
4040-05-12 / 16	4	0.5	10710	4010	0.04	0.68	10710	660	0.04	0.04
4060-05-18 / 24L	6	0.5	7140	4010	0.05	1	7140	550	0.07	0.05
4060-10-18 / 24L	6	1.0	7140	4010	0.05	1.08	7140	780	0.07	0.07
4080-05-26 / 32L	8	0.5	5360	4000	0.05	1.31	5360	400	0.06	0.04
4080-10-26 / 32L	8	1.0	5360	4000	0.05	1.35	5360	480	0.06	0.06
4080-15-24 / 32L	8	1.5	5360	4000	0.05	1.4	5360	670	0.06	0.08
4080-20-24 / 32L	8	2.0	3570	3010	0.09	1.41	5360	960	0.05	0.12
4100-05-30 / 30L	10	0.5	3570	3010	0.09	1.44	3570	280	0.06	0.05
4100-10-30 / 40L	10	1.0	3570	3010	0.09	1.49	3570	370	0.06	0.07
4100-15-30 / 40L	10	1.5	3570	3010	0.09	1.51	3570	520	0.06	0.1
4100-20-30 / 40L	10	2.0	3570	3010	0.09	1.53	3570	750	0.06	0.14
4100-30-30 / 40L	10	3.0	3570	3010	0.09	1.55	3571	750	0.06	0.16
4120-05-36 / 48L	12	0.5	2140	2400	0.12	1.45	2140	240	0.07	0.05
4120-10-36 / 48L	12	1.0	2140	2400	0.12	1.48	2140	310	0.07	0.07
4120-20-36 / 48L	12	2.0	2140	2400	0.12	1.53	2140	400	0.07	0.11
4120-30-36 / 48L	12	3.0	2140	2400	0.12	1.58	2140	520	0.07	0.17

SCHNITTDATEN

Material			Superlegierung							
			Inconel							
			Schruppen				Schlichten			
Artikel	DC mm	RE mm	n min ⁻¹	Vf mm/min	a _p mm	a _e mm	n min ⁻¹	Vf mm/min	a _p mm	a _e mm
4020-05-06	2	0.5	5140	810	0.03	0.33	5140	170	0.04	0.03
4030-05-12	3	0.5	3430	810	0.03	0.54	3430	190	0.04	0.04
4040-03-08	4	0.3	2570	810	0.04	0.66	2570	100	0.04	0.03
4040-05-12 / 16	4	0.5	2570	810	0.04	0.68	2570	130	0.04	0.04
4060-05-18 / 24L	6	0.5	1740	810	0.05	1	1740	110	0.07	0.05
4060-10-18 / 24L	6	1.0	1740	810	0.05	1.08	1740	160	0.07	0.07
4080-05-26 / 32L	8	0.5	1580	800	0.05	1.31	1580	80	0.06	0.04
4080-10-26 / 32L	8	1.0	1580	800	0.05	1.35	1580	100	0.06	0.06
4080-15-24 / 32L	8	1.5	1580	800	0.05	1.4	1580	130	0.06	0.08
4080-20-24 / 32L	8	2.0	1050	550	0.09	1.41	1580	190	0.05	0.12
4100-05-30 / 30L	10	0.5	1050	550	0.09	1.44	1050	50	0.06	0.05
4100-10-30 / 40L	10	1.0	1050	550	0.09	1.49	1050	70	0.06	0.07
4100-15-30 / 40L	10	1.5	1050	550	0.09	1.51	1050	100	0.06	0.1
4100-20-30 / 40L	10	2.0	1050	550	0.09	1.53	1050	140	0.06	0.14
4100-30-30 / 40L	10	3.0	1050	550	0.09	1.55	1051	140	0.06	0.16
4120-05-36 / 48L	12	0.5	640	410	0.12	1.45	640	40	0.07	0.05
4120-10-36 / 48L	12	1.0	640	410	0.12	1.48	640	50	0.07	0.07
4120-20-36 / 48L	12	2.0	640	410	0.12	1.53	640	70	0.07	0.12
4120-30-36 / 48L	12	3.0	640	410	0.12	1.58	640	100	0.07	0.17

Material			Gehärteter Stahl							
			HRC 36 ~ 55 / 1100 ~ 1450 N/mm ²							
			Schruppen				Schlichten			
Artikel	DC mm	RE mm	n min ⁻¹	Vf mm/min	a _p mm	a _e mm	n min ⁻¹	Vf mm/min	a _p mm	a _e mm
4020-05-06	2	0.5	24000	7000	0.02	0.59	24000	1070	0.05	0.04
4030-05-12	3	0.5	16000	7000	0.04	0.88	16000	1160	0.05	0.07
4040-03-08	4	0.3	12000	7000	0.05	1.17	12000	620	0.05	0.05
4040-05-12 / 16	4	0.5	12000	7000	0.05	1.26	12000	810	0.05	0.07
4060-05-18 / 24L	6	0.5	8000	5250	0.07	1.75	8000	670	0.1	0.08
4060-10-18 / 24L	6	1.0	8000	5250	0.08	1.75	8000	950	0.1	0.12
4080-05-26 / 32L	8	0.5	6000	4100	0.14	1.76	6000	580	0.1	0.1
4080-10-26 / 32L	8	1.0	6000	4100	0.16	1.76	6000	830	0.1	0.14
4080-15-24 / 32L	8	1.5	6000	4100	0.17	1.84	6000	1040	0.1	0.17
4080-20-24 / 32L	8	2.0	6000	4100	0.18	1.96	6000	1170	0.1	0.2
4100-05-30 / 30L	10	0.5	4800	4100	0.18	2.03	4800	520	0.1	0.11
4100-10-30 / 40L	10	1.0	4800	4100	0.19	2.1	4800	740	0.1	0.15
4100-15-30 / 40L	10	1.5	4800	4100	0.19	2.25	4800	960	0.1	0.18
4100-20-30 / 40L	10	2.0	4800	4100	0.2	2.35	4800	1050	0.1	0.22
4100-30-30 / 40L	10	3.0	4800	4100	0.2	2.45	4800	1180	0.1	0.25
4120-05-36 / 48L	12	0.5	4000	4100	0.21	2.8	4000	690	0.1	0.18
4120-10-36 / 48L	12	1.0	4000	4100	0.21	2.8	4000	820	0.1	0.21
4120-20-36 / 48L	12	2.0	4000	4100	0.21	2.8	4000	960	0.1	0.24
4120-30-36 / 48L	12	3.0	4000	4100	0.21	2.8	4000	1080	0.1	0.27



**NEUE*
MODELLE**

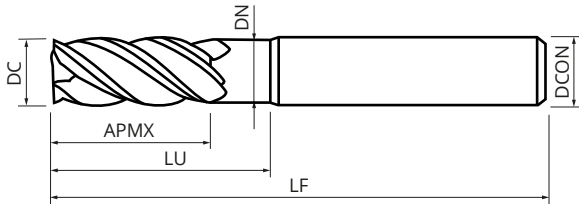

- Zur Anwendung in rostfreiem Stahl, Superlegierungen und Stahl
- Mit extra scharfer Schneidkante

ABMESSUNGEN

Artikelnummer (WGR. 9814)	DC mm	APMX mm	LU mm	LF mm	DCON mm	DN mm	ZEFP
GSSVA 4025	2.5	8	14	57	6	2.3	4
GSSVA 4030	3	8	15	57	6	2.8	4
GSSVA 4040	4	9	15	57	6	3.8	4
GSSVA 4050	5	11	17	57	6	4.8	4
GSSVA 4060	6	13	21	57	6	5.8	4
GSSVA 4080	8	19	27	63	8	7.6	4
GSSVA 4100	10	22	32	72	10	9.5	4
GSSVA 4120	12	26	38	83	12	11.5	4
* GSSVA 4160	16	32	44	92	16	15.5	4

SCHNITTDATEN

Bearbeitung		UMFANGSFRÄSEN									
Material	Bemerkung	a _p (xD)	a _e (xD)	V _c m/min	2.5 mm/Z	4 mm/Z	6 mm/Z	8 mm/Z	10 mm/Z	12 mm/Z	16 mm/Z
Stahl	< 850 N/mm ²	2	0.5	90 - 100	0.013	0.015	0.020	0.025	0.030	0.040	0.050
	< 1200 N/mm ²	2	0.5	60 - 90	0.013	0.015	0.020	0.025	0.030	0.040	0.050
	< 1400 N/mm ²										
Rostfreier Stahl	< 750 N/mm ²	2	0.5	70 - 80	0.014	0.015	0.020	0.025	0.030	0.040	0.050
	< 950 N/mm ²	1.8	0.5	60 - 70	0.014	0.015	0.020	0.025	0.030	0.040	0.050
Guss	< 300 HB										
Superlegierung	Titan < 1100 N/mm ² HRSA < 1300 N/mm ²	1.5	0.5	35 - 45	0.008	0.010	0.013	0.017	0.020	0.028	0.035

Bearbeitung		UMFANGSFRÄSEN HSC									
Material	Bemerkung	a _p (xD)	a _e (xD)	V _c m/min	2.5 mm/Z	4 mm/Z	6 mm/Z	8 mm/Z	10 mm/Z	12 mm/Z	16 mm/Z
Stahl	< 850 N/mm ²	2	0.15	100 - 120	0.035	0.038	0.050	0.065	0.078	0.104	0.129
	< 1200 N/mm ²	2	0.15	70 - 100	0.035	0.038	0.050	0.065	0.078	0.104	0.129
	< 1400 N/mm ²										
Rostfreier Stahl	< 750 N/mm ²	2	0.15	90 - 100	0.034	0.038	0.050	0.065	0.078	0.104	0.129
	< 950 N/mm ²	1.8	0.15	80 - 90	0.034	0.038	0.050	0.065	0.078	0.104	0.129
Guss	< 300 HB										
Superlegierung	Titan < 1100 N/mm ² HRSA < 1300 N/mm ²	1.5	0.15	50 - 60	0.015	0.017	0.024	0.030	0.034	0.048	0.059

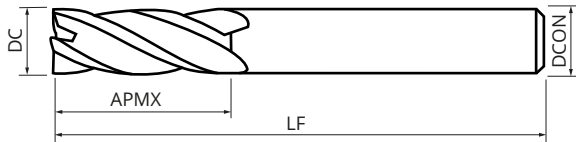

■ Zur Anwendung in Stahl bis HRC 55

ABMESSUNGEN

Artikelnummer (WGR. 7780)	DC mm	APMX mm	LF mm	DCON mm	ZEFP
GS 4010	1	2.5	45	4	4
GS 4015	1.5	3.75	45	4	4
GS 4020	2	5	45	4	4
GS 4030	3	8	45	6	4
GS 4040	4	11	45	6	4
GS 4060	6	15	60	6	4
GS 4080	8	19	60	8	4
GS 4100	10	25	70	10	4

SCHNITTDATEN

Material	Stahl							
	~ HRC 20 / ~ 800 N/mm ²							
	Standard Fräsbearbeitung				HSC Fräsen			
DC mm	n min ⁻¹	Vf mm/min	a _p mm	a _e mm	n min ⁻¹	Vf mm/min	a _p mm	a _e mm
1	20000	240	2.5	0.05	-	-	-	-
1.5	13500	245	3.75	0.075	-	-	-	-
2	1100	245	5	0.1	-	-	-	-
3	7400	370	7.5	0.15	30000	1500	7.5	0.15
4	5900	435	10	0.2	23800	1755	10	0.2
6	4400	580	15	0.3	15900	2095	15	0.3
8	3300	550	20	0.4	11900	1958	20	0.4
10	2600	525	25	0.5	9500	1920	25	0.5

SCHNITTDATEN

Material	Rostfreier Stahl							
	ferritisch und martensitisch							
	Standard Fräsbearbeitung				HSC Fräsen			
DC mm	n min ⁻¹	Vf mm/min	a _p mm	a _e mm	n min ⁻¹	Vf mm/min	a _p mm	a _e mm
1	15000	215	2.5	0.05	-	-	-	-
1.5	10000	215	3.75	0.075	-	-	-	-
2	8500	215	5	0.1	-	-	-	-
3	6400	260	7.5	0.15	26500	1075	7.5	0.15
4	5000	340	10	0.2	19800	1345	10	0.2
6	3500	415	15	0.3	13200	1565	15	0.3
8	2600	415	20	0.4	9900	1580	20	0.4
10	2100	405	25	0.5	7900	1525	25	0.5

Material	Vorgehärteter Stahl							
	HRC 30 - 45							
	Standard Fräsbearbeitung				HSC Fräsen			
DC mm	n min ⁻¹	Vf mm/min	a _p mm	a _e mm	n min ⁻¹	Vf mm/min	a _p mm	a _e mm
1	11000	85	2.5	0.05	-	-	-	-
1.5	8000	90	3.75	0.075	-	-	-	-
2	6400	90	5	0.1	-	-	-	-
3	4500	105	7.5	0.15	21200	495	7.5	0.15
4	3500	120	10	0.2	15800	540	10	0.2
6	2450	130	15	0.3	10600	560	15	0.3
8	1850	125	20	0.4	7900	535	20	0.4
10	1450	125	25	0.5	6300	545	25	0.5

Material	Gehärteter Stahl							
	HRC 46 - 55							
	Standard Fräsbearbeitung				HSC Fräsen			
DC mm	n min ⁻¹	Vf mm/min	a _p mm	a _e mm	n min ⁻¹	Vf mm/min	a _p mm	a _e mm
1	7100	40	0.02	0.59	-	-	-	-
1.5	5100	50	0.04	0.88	-	-	-	-
2	4000	55	0.05	1.17	-	-	-	-
3	2800	65	0.05	1.26	15800	365	0.05	0.07
4	2150	70	0.07	1.75	11900	385	0.1	0.08
6	1500	70	0.08	1.75	7900	370	0.1	0.12
8	1200	70	0.14	1.76	5900	345	0.1	0.1
10	950	65	0.16	1.76	4700	320	0.1	0.14



6-8
ZEFP

~2xD
APMX



HA (h6)



x°



C x 45°

SST
COAT

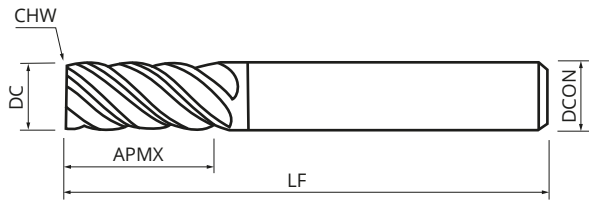

- Besonders gut geeignet für Feinschicht-Bearbeitungen
- <5 µm Verjüngung für exakte Winkelgenauigkeit und Planparallelität

ABMESSUNGEN

Artikelnummer (WGR. 9826)	DC mm	APMX mm	LF mm	DCON mm	CHW mm	ZEFP
FCZM 6030-HP	3	8	57	6	0.05	6
FCZM 6040-HP	4	11	57	6	0.05	6
FCZM 6050-HP	5	13	57	6	0.05	6
FCZM 6060-HP	6	13	57	6	0.05	6
FCZM 6080-HP	8	19	63	8	0.1	6
FCZM 6100-HP	10	22	72	10	0.1	6
FCZM 6120-HP	12	26	83	12	0.1	6
FCZM 6160-HP	16	32	92	16	0.15	6
FCZM 8200-HP	20	38	104	20	0.15	8

SCHNITTDATEN

Bearbeitung		UMFANGFRÄSEN										
Material	Bemerkung	a_p (xD)	a_e (xD)	V_c m/min	3 mm/Z	4 mm/Z	6 mm/Z	8 mm/Z	10 mm/Z	12 mm/Z	16 mm/Z	20 mm/Z
Stahl	< 850 N/mm ²	1.5	0.15 - 0.2	180 - 220	0.010	0.015	0.025	0.040	0.050	0.060	0.070	0.107
	< 1200 N/mm ²	1.5	0.15 - 0.2	150 - 180	0.08	0.012	0.022	0.035	0.045	0.052	0.06	0.086
	< 1400 N/mm ²	1.5	0.15 - 0.2	120 - 150	0.005	0.010	0.020	0.030	0.040	0.045	0.050	0.074
Rostfreier Stahl	< 750 N/mm ²	1.5	0.15 - 0.2	100 - 130	0.003	0.005	0.013	0.020	0.028	0.035	0.043	0.063
	< 950 N/mm ²	1.5	0.15 - 0.2	80 - 100	0.003	0.005	0.013	0.020	0.028	0.036	0.043	0.064
Guss	< 300 HB	1.5	0.15 - 0.2	180 - 220	0.010	0.015	0.025	0.040	0.050	0.060	0.070	0.107
Superlegierung	Titan < 1100 N/mm ²	1.5	0.15 - 0.2	80 - 90	0.002	0.005	0.010	0.015	0.020	0.025	0.033	0.054
	HRSA < 1300 N/mm ²											

OBERFLÄCHENGÜTE

		▼		▼		▼		▼		▼		▼		▼
Rz	-	160	100	63	40	25	16	-						
Ra	-	50	25	12.5	6.3	3.2	3.2	-						
	-	N12	N11	N10	N9	N8	N8	-						
		▼	▼	▼	▼	▼	▼	▼	▼	▼	▼	▼	▼	▼
Rz	10	6.3	4	2.5	1.6	1	0.63	0.25						
Ra	1.6	0.8	0.8	0.4	0.2	0.1	0.05	0.025						
	N7	N6	N6	N5	N4	N3	N2	N1						



4-6
ZEFP

HA (h6)



SST
COAT



Abb. 1



Abb. 2

- Besonders gut geeignet für das effiziente Vorschlichten und Schlichten von Stahl bis HRC 65
- 25° Anstellwinkel

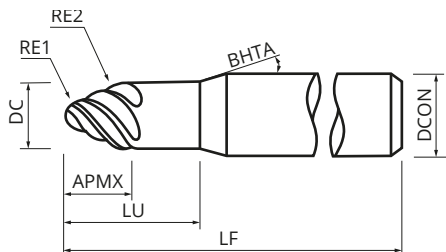
ABMESSUNGEN

Artikelnummer (WGR. 9826)	DC mm	RE1 mm	RE2 mm	APMX mm	LU mm	BHTA °	LF mm	DCON mm	ZEFP	Abb.
HBCBC 4050-08-40	5	0.8	40	4.49	8.3	16	50	6	4	1
HBCBC 4080-15-100	8	1.5	100	6.9	-	-	55	8	4	2
HBCBC 6080-15-100	8	1.5	100	6.9	-	-	55	8	6	2
HBCBC 4100-20-160	10	2	160	8.43	20	16	70	12	4	1
HBCBC 6100-20-160	10	2	160	8.43	20	16	70	12	6	1

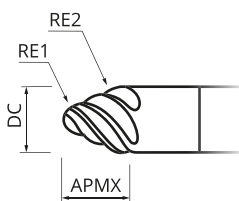
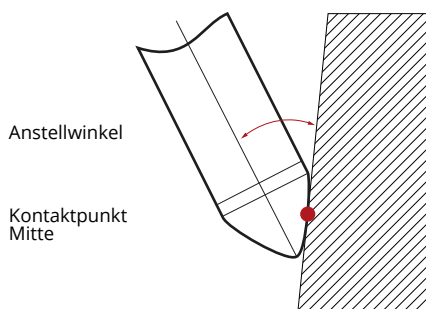

RE-Toleranz	
RE1 ≤ 2	RE2 ≤ 160
± 0.01	± 0.01

SCHNITTDATEN

Material		Kohlenstoffstahl											
		HB 180 – 250											
		Schruppen				Schichten mit RE2				Schichten mit RE1			
DC mm	ZEFP	n min ⁻¹	Vf mm/min	a _p mm	a _e mm	n min ⁻¹	Vf mm/min	a _p mm	a _e mm	n min ⁻¹	Vf mm/min	a _p mm	a _e mm
5	4	14100	3090	0.9	0.4	15500	2040	0.47	0.07	16900	2230	0.1	0.12
8	4	8800	3160	1.3	0.6	9700	2090	0.75	0.09	10600	2280	0.13	0.15
10	4	7100	3230	1.4	0.7	7800	2130	0.95	0.1	8500	2330	0.15	0.18
8	6	8800	4730	1.3	0.3	9700	3130	0.75	0.09	10600	2280	0.13	0.15
10	6	7100	4840	1.4	0.35	7800	3200	0.95	0.1	8500	2330	0.15	0.18

Material		Stahl											
		HRC 25 – 34											
		Schruppen				Schichten mit RE2				Schichten mit RE1			
DC mm	ZEFP	n min ⁻¹	Vf mm/min	a _p mm	a _e mm	n min ⁻¹	Vf mm/min	a _p mm	a _e mm	n min ⁻¹	Vf mm/min	a _p mm	a _e mm
5	4	12800	2530	0.86	0.4	13900	1650	0.47	0.07	15200	1810	0.1	0.12
8	4	8000	2580	1.24	0.6	8700	1690	0.75	0.09	9500	1850	0.13	0.15
10	4	6400	2640	1.33	0.7	7000	1730	0.95	0.1	7600	1890	0.15	0.18
8	6	8000	3870	1.24	0.3	8700	2530	0.75	0.09	9500	1850	0.13	0.15
10	6	6400	3960	1.33	0.35	7000	2590	0.95	0.1	7600	1890	0.15	0.18

Material		Vorgehärteter Stahl											
		HRC 35 – 45											
		Schruppen				Schichten mit RE2				Schichten mit RE1			
DC mm	ZEFP	n min ⁻¹	Vf mm/min	a _p mm	a _e mm	n min ⁻¹	Vf mm/min	a _p mm	a _e mm	n min ⁻¹	Vf mm/min	a _p mm	a _e mm
5	4	11800	2100	0.81	0.4	12500	1340	0.47	0.07	13700	1470	0.1	0.12
8	4	7400	2150	1.17	0.6	7900	1370	0.75	0.09	8600	1500	0.13	0.15
10	4	5900	2200	1.26	0.7	6300	1400	0.95	0.1	6900	1530	0.15	0.18
8	6	7400	3230	1.17	0.3	7900	2050	0.75	0.09	8600	1500	0.13	0.15
10	6	5900	3300	1.26	0.35	6300	2100	0.95	0.1	6900	1530	0.15	0.18

Material		Gehärteter Stahl											
		HRC 46 – 55											
		Schruppen				Schichten mit RE2				Schichten mit RE1			
DC mm	ZEFP	n min ⁻¹	Vf mm/min	a _p mm	a _e mm	n min ⁻¹	Vf mm/min	a _p mm	a _e mm	n min ⁻¹	Vf mm/min	a _p mm	a _e mm
5	4	10600	1690	0.77	0.32	11300	1090	0.47	0.06	12400	1190	0.1	0.1
8	4	6600	1730	1.11	0.48	7100	1110	0.75	0.07	7700	1220	0.13	0.12
10	4	5300	1770	1.2	0.56	5700	1140	0.95	0.08	6200	1240	0.15	0.14
8	6	6600	2590	1.11	0.24	7100	1660	0.75	0.07	7700	1220	0.13	0.12
10	6	5300	2650	1.2	0.28	5700	1700	0.95	0.08	6200	1240	0.15	0.14

SCHNITTDATEN

Material		Gehärteter Stahl											
		HRC 56 – 64											
		Schruppen				Schichten mit RE2				Schichten mit RE1			
DC mm	ZEFP	n min ⁻¹	Vf mm/min	a _p mm	a _e mm	n min ⁻¹	Vf mm/min	a _p mm	a _e mm	n min ⁻¹	Vf mm/min	a _p mm	a _e mm
5	4	8600	1250	0.69	0.28	10200	880	0.47	0.05	11100	960	0.1	0.08
8	4	5400	1270	1	0.42	6400	900	0.75	0.06	7000	990	0.13	0.12
10	4	4300	1300	1.08	0.49	5100	920	0.95	0.07	5600	1010	0.15	0.14
8	6	5400	1910	1	0.21	6400	1350	0.75	0.06	7000	990	0.13	0.12
10	6	4300	1950	1.08	0.25	5100	1380	0.95	0.07	5600	1010	0.15	0.14

Material		Gehärteter Stahl											
		HRC 65 – 70											
		Schruppen				Schichten mit RE2				Schichten mit RE1			
DC mm	ZEFP	n min ⁻¹	Vf mm/min	a _p mm	a _e mm	n min ⁻¹	Vf mm/min	a _p mm	a _e mm	n min ⁻¹	Vf mm/min	a _p mm	a _e mm
5	4	7100	920	0.63	0.24	7600	600	0.47	0.04	8400	650	0.1	0.07
8	4	4400	940	0.9	0.36	4800	610	0.75	0.05	5200	670	0.13	0.09
10	4	3600	960	0.97	0.42	3800	620	0.95	0.06	4200	680	0.15	0.11
8	6	4400	1400	0.9	0.18	4800	910	0.75	0.05	5200	670	0.13	0.09
10	6	3600	1430	0.97	0.21	3800	930	0.95	0.06	4200	680	0.15	0.11

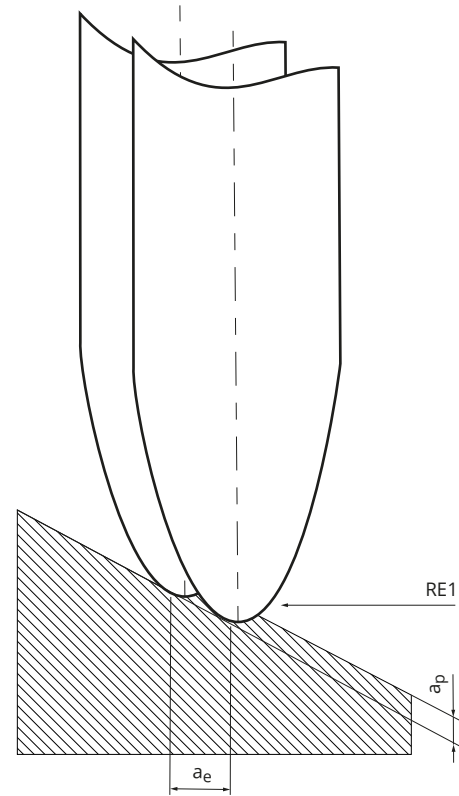
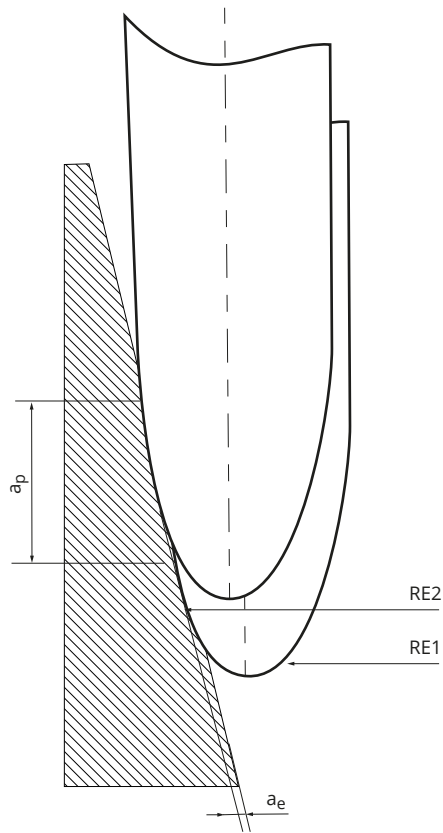

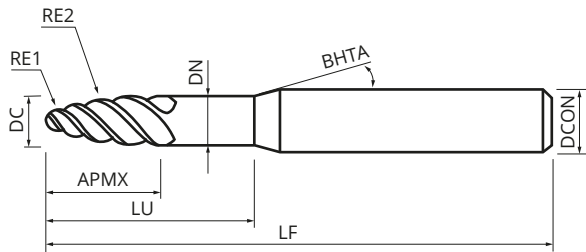

- Besonders gut geeignet für das effiziente Vorschlichten und Schlichten von Stahl bis HRC 65
- 9.15° Anstellwinkel

ABMESSUNGEN

Artikelnummer (WGR. 9826)	DC mm	RE1 mm	RE2 mm	APMX mm	LU mm	BHTA °	LF mm	DCON mm	DN mm	ZFP
HBTBC 4030-05-20	3	0.5	20	6.73	10	15	50	4	2.9	4
HBTBC 4050-10-40	5	1	40	10.32	20	15	60	6	4.8	4
HBTBC 4075-15-60	7.5	1.5	60	15.53	30	15	75	8	7.3	4
HBTBC 6075-15-60	7.5	1.5	60	15.53	30	15	75	8	7.3	6
HBTBC 4100-20-80	10	2	80	20.7	40	15	100	12	9.5	4
HBTBC 6100-20-80	10	2	80	20.7	40	15	100	12	9.5	6

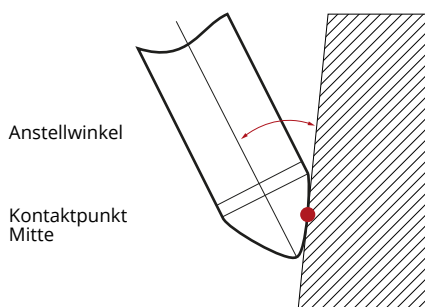

RE-Toleranz	
RE1 ≤ 2	RE2 ≤ 160
± 0.01	± 0.01

SCHNITTDATEN

Material		Kohlenstoffstahl											
		HB 180 - 250											
		Schruppen				Schichten mit RE2				Schichten mit RE1			
DC mm	ZEFP	n min ⁻¹	Vf mm/min	a _p mm	a _e mm	n min ⁻¹	Vf mm/min	a _p mm	a _e mm	n min ⁻¹	Vf mm/min	a _p mm	a _e mm
3	4	23400	2810	0.6	0.2	25700	1850	0.33	0.055	28200	2030	0.07	0.07
5	4	14100	3090	0.9	0.4	15500	2040	0.47	0.07	16900	2230	0.1	0.1
7.5	4	9400	3370	1.3	0.6	10300	2220	0.58	0.09	11300	2440	0.1	0.1
10	4	7100	3230	1.4	0.7	7800	2130	0.67	0.1	8500	2330	0.12	0.12
7.5	6	9400	5050	1.3	0.6	10300	3330	0.58	0.09	11300	2440	0.1	0.1
10	6	7100	4840	1.4	0.7	7800	3200	0.67	0.1	8500	2330	0.12	0.12

Material		Stahl											
		HRC 25 - 34											
		Schruppen				Schichten mit RE2				Schichten mit RE1			
DC mm	ZEFP	n min ⁻¹	Vf mm/min	a _p mm	a _e mm	n min ⁻¹	Vf mm/min	a _p mm	a _e mm	n min ⁻¹	Vf mm/min	a _p mm	a _e mm
3	4	21300	2300	0.57	0.2	23200	1500	0.33	0.055	25400	1650	0.07	0.07
5	4	12800	2530	0.86	0.4	13900	1650	0.47	0.07	15200	1810	0.1	0.1
7.5	4	8500	2760	1.24	0.6	9300	1800	0.58	0.09	10200	1970	0.1	0.1
10	4	6400	2640	1.33	0.7	7000	1730	0.67	0.1	7600	1890	0.12	0.12
7.5	6	8500	4130	1.24	0.6	9300	2700	0.58	0.09	10200	1970	0.1	0.1
10	6	6400	3960	1.33	0.7	7000	2590	0.67	0.1	7600	1890	0.12	0.12

Material		Vorgehärteter Stahl											
		HRC 35 - 45											
		Schruppen				Schichten mit RE2				Schichten mit RE1			
DC mm	ZEFP	n min ⁻¹	Vf mm/min	a _p mm	a _e mm	n min ⁻¹	Vf mm/min	a _p mm	a _e mm	n min ⁻¹	Vf mm/min	a _p mm	a _e mm
3	4	19700	1910	0.54	0.2	20900	1220	0.33	0.055	22800	1330	0.07	0.07
5	4	11800	2100	0.81	0.4	12500	1340	0.47	0.07	13700	1470	0.1	0.1
7.5	4	7900	2300	1.17	0.6	8400	1460	0.58	0.09	9200	1600	0.1	0.1
10	4	5900	2200	1.26	0.7	6300	1400	0.67	0.1	6900	1530	0.12	0.12
7.5	6	7900	3440	1.17	0.6	8400	2190	0.58	0.09	9200	1600	0.1	0.1
10	6	5900	3300	1.26	0.7	6300	2100	0.67	0.1	6900	1530	0.12	0.12

SCHNITTDATEN

Material		Gehärteter Stahl											
		HRC 46 – 55											
		Schruppen				Schichten mit RE2				Schichten mit RE1			
DC mm	ZEFP	n min ⁻¹	Vf mm/min	a _p mm	a _e mm	n min ⁻¹	Vf mm/min	a _p mm	a _e mm	n min ⁻¹	Vf mm/min	a _p mm	a _e mm
3	4	17600	1540	0.51	0.16	18800	990	0.33	0.04	20600	1080	0.07	0.06
5	4	10600	1690	0.77	0.32	11300	1090	0.47	0.06	12400	1190	0.1	0.08
7.5	4	7100	1840	1.11	0.48	7500	1180	0.58	0.07	8300	1300	0.1	0.08
10	4	5300	1770	1.2	0.56	5700	1140	0.67	0.08	6200	1240	0.12	0.1
7.5	6	7100	2760	1.11	0.48	7500	1770	0.58	0.07	8300	1300	0.1	0.08
10	6	5300	2650	1.2	0.56	5700	1700	0.67	0.08	6200	1240	0.12	0.1

Material		Gehärteter Stahl											
		HRC 56 – 64											
		Schruppen				Schichten mit RE2				Schichten mit RE1			
DC mm	ZEFP	n min ⁻¹	Vf mm/min	a _p mm	a _e mm	n min ⁻¹	Vf mm/min	a _p mm	a _e mm	n min ⁻¹	Vf mm/min	a _p mm	a _e mm
3	4	14400	1130	0.46	0.14	16900	800	0.33	0.04	18500	880	0.07	0.05
5	4	8600	1250	0.69	0.28	10200	880	0.47	0.05	11100	960	0.1	0.08
7.5	4	5800	1360	1	0.42	6800	960	0.58	0.06	7400	1050	0.1	0.08
10	4	4300	1300	1.08	0.49	5100	920	0.67	0.07	5600	1010	0.12	0.1
7.5	6	5800	2040	1	0.42	6800	1440	0.58	0.06	7400	1050	0.1	0.08
10	6	4300	1950	1.08	0.49	5100	1380	0.67	0.07	5600	1010	0.12	0.1

Material		Gehärteter Stahl											
		HRC 65 – 70											
		Schruppen				Schichten mit RE2				Schichten mit RE1			
DC mm	ZEFP	n min ⁻¹	Vf mm/min	a _p mm	a _e mm	n min ⁻¹	Vf mm/min	a _p mm	a _e mm	n min ⁻¹	Vf mm/min	a _p mm	a _e mm
3	4	11700	830	0.42	0.12	12700	540	0.33	0.03	13900	590	0.07	0.04
5	4	7100	920	0.63	0.24	7600	600	0.47	0.04	8400	650	0.1	0.06
7.5	4	4700	1000	0.9	0.36	5100	650	0.58	0.05	5600	710	0.1	0.06
10	4	3600	960	0.97	0.42	3800	620	0.67	0.06	4200	680	0.12	0.07
7.5	6	4700	1490	0.9	0.36	5100	970	0.58	0.05	5600	710	0.1	0.06
10	6	3600	1430	0.97	0.42	3800	930	0.67	0.06	4200	680	0.12	0.07

GSXRM 4000 VHM-Schruppfräser

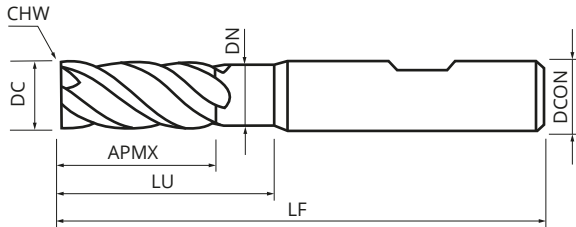

- Schrappfräser speziell geeignet für rostfreien Stahl, Superlegierungen und Stahl

ABMESSUNGEN

Artikelnummer (WGR. 9812)	DC mm	APMX mm	LU mm	LF mm	DCON mm	DN mm	CHW mm	ZEFP
GSXRM 4040	4	11	17	57	6	3.8	0.15	4
GSXRM 4050	5	13	19	57	6	4.8	0.15	4
GSXRM 4060	6	13	21	57	6	5.8	0.2	4
GSXRM 4080	8	19	27	63	8	7.6	0.2	4
GSXRM 4100	10	22	32	72	10	9.5	0.3	4
GSXRM 4120	12	26	38	83	12	11.5	0.35	4
GSXRM 4160	16	32	44	92	16	15.5	0.4	4
GSXRM 4200	20	38	54	104	20	19.5	0.5	4

SCHNITTDATEN

Bearbeitung		VOLLNUTFRÄSEN									
Material	Bemerkung	a_p (xD)	a_e (xD)	Vc m/min	4 mm/Z	6 mm/Z	8 mm/Z	10 mm/Z	12 mm/Z	16 mm/Z	20 mm/Z
Stahl	< 850 N/mm ²	1	1	120 - 140	0.024	0.036	0.048	0.060	0.072	0.096	0.120
	< 1200 N/mm ²	1	1	60 - 80	0.022	0.034	0.044	0.055	0.068	0.088	0.110
	< 1400 N/mm ²	1	1	50 - 70	0.020	0.030	0.040	0.050	0.060	0.080	0.100
Rostfreier Stahl	< 750 N/mm ²	1	1	60 - 80	0.020	0.030	0.040	0.050	0.060	0.080	0.100
	< 950 N/mm ²	0.5	1	40 - 60	0.016	0.024	0.032	0.040	0.048	0.064	0.080
Guss	< 300 HB	1	1	60 - 80	0.022	0.034	0.044	0.055	0.068	0.088	0.110
Superlegierung	Titan < 1100 N/mm ² HRSA < 1300 N/mm ²	0.3	1	50 - 60	0.016	0.024	0.032	0.040	0.048	0.064	0.080

Bearbeitung		UMFANGSFRÄSEN									
Material	Bemerkung	a_p (xD)	a_e (xD)	Vc m/min	4 mm/Z	6 mm/Z	8 mm/Z	10 mm/Z	12 mm/Z	16 mm/Z	20 mm/Z
Stahl	< 850 N/mm ²	1.5	0.5	160 - 180	0.024	0.036	0.048	0.060	0.072	0.096	0.120
	< 1200 N/mm ²	1.5	0.5	100 - 120	0.022	0.034	0.044	0.055	0.068	0.088	0.110
	< 1400 N/mm ²	1.5	0.5	90 - 110	0.020	0.030	0.040	0.050	0.060	0.080	0.100
Rostfreier Stahl	< 750 N/mm ²	2	0.5	100 - 120	0.020	0.030	0.040	0.050	0.060	0.080	0.100
	< 950 N/mm ²	1.5	0.25	80 - 100	0.022	0.034	0.044	0.055	0.068	0.088	0.110
Guss	< 300 HB	1	1	100 - 120	0.022	0.034	0.044	0.055	0.068	0.088	0.110
Superlegierung	Titan < 1100 N/mm ² HRSA < 1300 N/mm ²	1.5	0.25	60 - 70	0.016	0.024	0.032	0.040	0.048	0.064	0.080

Bearbeitung		HELIX-FRÄSEN									
Material	Bemerkung	α °	a_e (xD)	Vc m/min	4 mm/Z	6 mm/Z	8 mm/Z	10 mm/Z	12 mm/Z	16 mm/Z	20 mm/Z
Stahl	< 850 N/mm ²	6	0.4	120 - 140	0.019	0.029	0.038	0.047	0.054	0.072	0.090
	< 1200 N/mm ²	4	0.4	60 - 80	0.018	0.027	0.035	0.043	0.051	0.066	0.083
	< 1400 N/mm ²	2.5	0.4	50 - 70	0.016	0.024	0.032	0.039	0.045	0.060	0.075
Rostfreier Stahl	< 750 N/mm ²	4	0.4	60 - 80	0.016	0.024	0.032	0.039	0.045	0.060	0.075
	< 950 N/mm ²	2.5	0.4	40 - 60	0.013	0.019	0.026	0.031	0.036	0.048	0.060
Guss	< 300 HB	4	0.4	60 - 80	0.018	0.027	0.035	0.043	0.051	0.066	0.083
Superlegierung	Titan < 1100 N/mm ² HRSA < 1300 N/mm ²	2	0.4	50 - 60	0.013	0.019	0.026	0.031	0.036	0.048	0.060

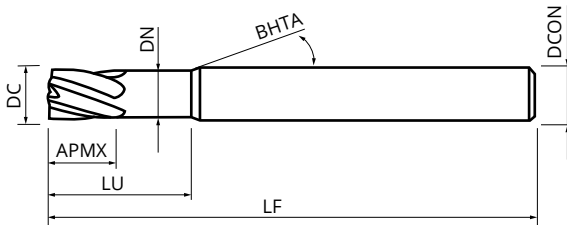

- Besonders gut geeignet in Stahl bis HRC 66
- Spezielle Stirngeometrie für Highfeed-Operationen
- RECAM-Toleranz 0.01mm

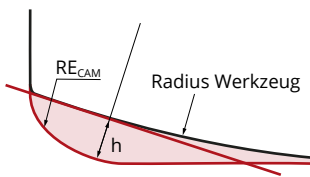

ABMESSUNGEN

Artikelnummer (WGR. 9819)	DC mm	RECAM mm	h mm	APMX mm	LU mm	BHTA °	LF mm	DCON mm	DN mm	ZEFP
RHCSN 4010R0088	1	0.088	0.017	1	3	16	58	6	0.9	4
RHCSN 4015R0132	1.5	0.132	0.026	1.5	4.5	16	58	6	1.4	4
RHCSN 4020R0176	2	0.176	0.034	2	6	16	58	6	1.8	4
RHCSN 4025R0220	2.5	0.220	0.043	2.5	7.5	16	58	6	2.3	4
RHCSN 4030R0264	3	0.264	0.051	3	9	16	58	6	2.8	4
RHCSN 6040R0352	4	0.352	0.068	4	12	16	58	6	3.8	6
RHCSN 6050R044	5	0.440	0.085	5	15	16	58	6	4.7	6
RHCSN 6060R0528	6	0.528	0.102	6	18	-	58	6	5.7	6
RHCSN 6080R0704	8	0.704	0.136	8	24	-	80	8	7.6	6
RHCSN 6100R088	10	0.880	0.170	10	30	-	80	10	9.5	6
RHCSN 6120R1056	12	1.056	0.204	12	36	-	100	12	11.5	6

SCHNITTDATEN

Material	Legierter Stahl				Hochlegierter Stahl				Werkzeugstahl			
	HB 180 - 250				HRC 25 - 34				HRC 35 - 45			
DC mm	n min ⁻¹	Vf mm/min	a _p mm	a _e mm	n min ⁻¹	Vf mm/min	a _p mm	a _e mm	n min ⁻¹	Vf mm/min	a _p mm	a _e mm
1	57200	10290	0.042	0.75	50900	8550	0.04	0.75	44500	7120	0.037	0.7
1.5	38200	10240	0.063	1.12	34000	8600	0.06	1.12	29500	7100	0.06	1.05
2	28600	10290	0.084	1.5	25400	8530	0.08	1.5	22200	7100	0.074	1.4
2.5	22900	10270	0.105	1.85	20400	8600	0.1	1.85	17700	7100	0.09	1.75
3	19000	10260	0.126	2.25	16900	8510	0.12	2.25	14800	7100	0.111	2.1
4	14300	15440	0.168	3	12700	12800	0.16	3	11100	10650	0.148	2.8
5	11400	15390	0.21	3.75	10100	12720	0.2	3.75	8900	10680	0.185	3.5
6	9500	15390	0.252	4.5	8400	12700	0.24	4.5	7400	10650	0.222	4.2
8	7100	15330	0.336	6	6300	12700	0.32	6	5500	10560	0.296	5.6
10	5700	15390	0.42	7.5	5000	12600	0.4	7.5	4400	10560	0.37	7
12	4700	15220	0.504	9	4200	12700	0.48	9	3700	10650	0.444	8.4

Material	Gehärteter Stahl											
	HRC 48 - 51				HRC 52 - 55				HRC 56 - 59			
DC mm	n min ⁻¹	Vf mm/min	a _p mm	a _e mm	n min ⁻¹	Vf mm/min	a _p mm	a _e mm	n min ⁻¹	Vf mm/min	a _p mm	a _e mm
1	38100	6090	0.037	0.7	31800	5080	0.037	0.7	27000	3240	0.03	0.7
1.5	25500	6100	0.06	1.05	21200	5100	0.06	1.05	18000	3200	0.05	1.05
2	19000	6080	0.074	1.4	15900	5080	0.074	1.4	13500	3240	0.06	1.4
2.5	15300	6100	0.09	1.75	12700	5100	0.09	1.75	10800	3200	0.08	1.75
3	12700	6090	0.111	2.1	10600	5080	0.111	2.1	9000	3240	0.09	2.1
4	9500	9120	0.148	2.8	7900	7580	0.148	2.8	6700	4820	0.12	2.8
5	7600	9120	0.185	3.5	6300	7560	0.185	3.5	5400	4860	0.15	3.5
6	6300	9070	0.222	4.2	5300	7310	0.222	4.2	4500	4860	0.18	4.2
8	4700	9020	0.296	5.6	3900	7250	0.296	5.6	3300	4750	0.24	5.6
10	3800	9120	0.37	7	3100	7250	0.37	7	2700	4860	0.3	7
12	3100	8920	0.444	8.4	2600	7330	0.444	8.4	2200	4750	0.36	8.4

Material	Gehärteter Stahl							
	HRC 60 - 62				HRC 63 - 66			
DC mm	n min ⁻¹	Vf mm/min	a _p mm	a _e mm	n min ⁻¹	Vf mm/min	a _p mm	a _e mm
1	22200	2220	0.025	0.65	19000	1520	0.02	0.6
1.5	14800	2200	0.04	0.98	12700	1500	0.03	0.9
2	11100	2220	0.05	1.3	9500	1520	0.04	1.2
2.5	8900	2200	0.06	1.63	7600	1500	0.05	1.5
3	7400	2220	0.075	1.95	6300	1510	0.06	1.8
4	5500	3300	0.1	2.6	4700	2250	0.08	2.4
5	4400	3300	0.125	3.25	3800	2280	0.1	3
6	3700	3330	0.15	3.9	3100	2230	0.12	3.6
8	2700	3240	0.2	5.2	2300	2200	0.16	4.8
10	2200	3300	0.25	6.5	1900	2280	0.2	6
12	1800	3240	0.3	7.8	1500	2160	0.24	7.2

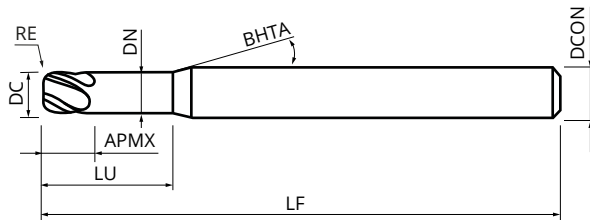

- Besonders gut geeignet in Stahl bis HRC 66
- Spezielle Stirngeometrie für Highfeed-Operationen

DC	RE	Toleranzen	
1 - 6	R0.2 - R1.5	0/-0.015 DC-TOL	±0.015 RE
8 - 10	R2	0/-0.02 DC-TOL	±0.015 RE

ABMESSUNGEN

Artikelnummer (WGR. 9819)	DC mm	RE mm	APMX mm	LU mm	BHTA °	LF mm	DCON mm	DN mm	ZEFP
RHESN 4010-02-030	1	0.2	0.7	3	16	60	6	0.95	4
RHESN 4015-05-045	1.5	0.5	1	4.5	16	60	6	1.4	4
RHESN 4020-05-060	2	0.5	1.3	6	16	60	6	1.9	4
RHESN 4030-08-090	3	0.8	2	9	16	60	6	2.9	4
RHESN 4040-10-120	4	1	2.6	12	16	60	6	3.9	4
RHESN 5050-12-150	5	1.2	3.3	15	16	60	6	4.9	5
RHESN 5060-15-180	6	1.5	4	18	45	60	6	5.85	5
RHESN 6080-20-240	8	2	5.3	24	45	80	8	7.8	6
RHESN 6100-20-300	10	2	6.6	30	45	90	10	9.5	6
RHESN 6120-20-360	12	2	8	36	45	100	12	11.5	6

Restmaterial stirnseitig			
Ø mm	h mm	Ø mm	h mm
1	0.0075	5	0.037
1.5	0.011	6	0.045
2	0.015	8	0.06
3	0.022	10	0.075
4	0.03	12	0.09

Maximal undefiniertes Aufmaß nach dem Schruppen stirnseitig
Nicht zum Schlichten geeignet

SCHNITTDATEN

Material	Hochlegierter Stahl				Werkzeugstahl			
	HRC 25 - 34				HRC 35 - 45			
DC mm	n min ⁻¹	Vf mm/min	a _p mm	a _e mm	n min ⁻¹	Vf mm/min	a _p mm	a _e mm
1	36630	5860	0.08	0.3	33440	4010	0.06	0.3
1.5	24420	6350	0.09	0.4	22290	4730	0.08	0.4
2	18310	7030	0.13	0.5	16720	5350	0.12	0.5
3	12210	7030	0.16	0.7	11150	5350	0.14	0.7
4	9160	7470	0.21	1.0	8360	5680	0.18	1.0
5	7320	9670	0.26	1.3	6690	7360	0.23	1.3
6	6100	9160	0.31	1.5	5570	6970	0.28	1.5
8	4580	11540	0.39	2.0	4180	8780	0.35	2.0
10	3660	11870	0.45	3.0	3340	9030	0.39	3.0
12	3050	10990	0.47	4.0	2790	8360	0.41	4.0

Material	Gehärteter Stahl							
	HRC 46 - 54				HRC 55 - 65			
DC mm	n min ⁻¹	Vf mm/min	a _p mm	a _e mm	n min ⁻¹	Vf mm/min	a _p mm	a _e mm
1	27070	3030	0.05	0.3	20700	2070	0.04	0.3
1.5	18050	3610	0.07	0.4	13800	2430	0.05	0.4
2	13540	4330	0.10	0.5	10350	1320	0.07	0.5
3	9020	4330	0.12	0.7	6900	1320	0.08	0.7
4	6770	4600	0.16	1.0	5180	1410	0.11	1.0
5	5410	5960	0.20	1.3	4140	1820	0.13	1.3
6	4510	5640	0.24	1.5	3450	1730	0.16	1.5
8	3380	7110	0.30	2.0	2590	2170	0.20	2.0
10	2710	7310	0.34	3.0	2070	2240	0.23	3.0
12	2260	6770	0.36	4.0	1730	2070	0.24	4.0

EFLB 4000 VHM-Kugelfräser

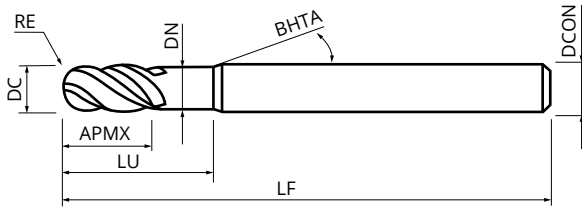

- Zum Schruppen und Vorschlichten in vorgehärtetem und gehärtetem Stahl von 30 bis 70 HRC

DC	RE	Toleranzen	
1 - 3	R0.5 - R1.5	0/-0.01 DC-TOL	±0.005 RE
4 - 6	R2 - R3	0/-0.014 DC-TOL	±0.007 RE
8 - 12	R4 - R6	0/-0.02 DC-TOL	±0.01 RE

ABMESSUNGEN

Artikelnummer (WGR. 9810)	DC mm	RE mm	APMX mm	LU mm	DN mm	LF mm	DCON mm	BHTA °	ZEFP
EFLB 4010-030-4	1	0.5	1.5	3	0.95	50	4	15	4
EFLB 4010-030-6	1	0.5	1.5	3	0.95	50	6	15	4
EFLB 4015-045-4	1.5	0.75	2.5	4.5	1.43	50	4	15	4
EFLB 4015-045-6	1.5	0.75	2.5	4.5	1.43	50	6	15	4
EFLB 4020-060-4	2	1	3	6	1.9	50	4	15	4
EFLB 4020-060-6	2	1	3	6	1.9	50	6	15	4
EFLB 4025-075-4	2.5	1.25	4	7.5	2.38	50	4	15	4
EFLB 4025-075-6	2.5	1.25	4	7.5	2.38	50	6	15	4
EFLB 4030-090-4	3	1.5	4.5	9	2.9	70	4	15	4
EFLB 4030-090-6	3	1.5	4.5	9	2.9	70	6	15	4
EFLB 4040-120-4	4	2	6	12	3.9	70	4	-	4
EFLB 4040-120-6	4	2	6	12	3.9	70	6	15	4
EFLB 4050-150-6	5	2.5	7.5	15	4.7	80	6	15	4
EFLB 4060-180-6	6	3	9	18	5.7	90	6	-	4
EFLB 4060-180-6S	6	3	9	18	5.7	60	6	-	4
EFLB 4080-240-8	8	4	12	24	7.6	100	8	-	4
EFLB 4080-240-8S	8	4	12	24	7.6	70	8	-	4
EFLB 4100-300-10	10	5	15	30	9.5	100	10	-	4
EFLB 4100-300-10S	10	5	15	30	9.5	70	10	-	4
EFLB 4120-360-12	12	6	18	36	11.5	110	12	-	4
EFLB 4120-360-12S	12	6	18	36	11.5	84	12	-	4

SCHNITTDATEN – SCHRUPPEN

Material		Vorgehärteter Stahl				(Vor-)gehärteter Stahl				Gehärteter Stahl			
		30 – 41 HRC				42 – 51 HRC				52 – 57 HRC			
DC mm	RE mm	n min ⁻¹	Vf mm/min	a _p mm	a _e mm	n min ⁻¹	Vf mm/min	a _p mm	a _e mm	n min ⁻¹	Vf mm/min	a _p mm	a _e mm
1	R0.5	40000	5940	0.13	0.39	40000	4160	0.09	0.33	40000	3200	0.08	0.30
1.5	R0.75	40000	7430	0.19	0.66	40000	5200	0.14	0.55	38200	3820	0.12	0.50
2	R1	39000	10150	0.24	0.79	31800	5790	0.17	0.66	28600	4010	0.15	0.60
2.5	R1.25	31200	9280	0.32	1.06	25400	5290	0.23	0.88	22900	3660	0.20	0.80
3	R1.5	26000	9660	0.41	1.26	21200	5520	0.29	1.04	19100	3820	0.25	0.95
4	R2	19500	9420	0.49	1.59	15900	5380	0.35	1.32	14300	3720	0.30	1.20
5	R2.5	15600	9860	0.65	2.12	12700	5630	0.47	1.76	11400	3890	0.40	1.60
6	R3	13000	9660	0.77	2.52	10600	5520	0.55	2.09	9500	3820	0.47	1.90
8	R4	9700	10150	1.06	3.32	7900	5790	0.76	2.75	7100	4010	0.65	2.50
10	R5	7800	10150	1.31	4.12	6300	5790	0.94	3.41	5700	4010	0.80	3.10
12	R6	6500	9660	1.56	4.65	5300	5520	1.12	3.85	4700	3820	0.95	3.50

Material		Gehärteter Stahl											
		58 – 62 HRC				63 – 66 HRC				67 – 70 HRC			
DC mm	RE mm	n min ⁻¹	Vf mm/min	a _p mm	a _e mm	n min ⁻¹	Vf mm/min	a _p mm	a _e mm	n min ⁻¹	Vf mm/min	a _p mm	a _e mm
1	R0.5	40000	2240	0.06	0.24	38200	1490	0.05	0.20	31800	870	0.04	0.16
1.5	R0.75	31800	2220	0.09	0.41	25400	1240	0.08	0.33	21200	720	0.06	0.27
2	R1	23800	2340	0.12	0.49	19100	1310	0.10	0.40	15900	760	0.07	0.33
2.5	R1.25	19100	2140	0.16	0.65	15200	1190	0.13	0.53	12700	690	0.10	0.44
3	R1.5	15900	2220	0.20	0.77	12700	1240	0.16	0.63	10600	720	0.12	0.52
4	R2	11900	2170	0.24	0.98	9500	1210	0.20	0.80	7900	710	0.15	0.66
5	R2.5	9500	2270	0.32	1.31	7600	1270	0.26	1.07	6300	740	0.20	0.88
6	R3	7900	2220	0.38	1.55	6300	1240	0.31	1.27	5300	720	0.23	1.04
8	R4	5900	2340	0.53	2.05	4700	1310	0.43	1.68	3900	760	0.32	1.37
10	R5	4700	2340	0.65	2.54	3800	1310	0.53	2.08	3100	760	0.40	1.70
12	R6	3900	2220	0.77	2.87	3100	1240	0.63	2.35	2600	720	0.47	1.92

SCHNITTDATEN – SCHLICHTEN

Material		Vorgehärteter Stahl				(Vor-)gehärteter Stahl				Gehärteter Stahl			
		30 – 41 HRC				42 – 51 HRC				52 – 57 HRC			
DC mm	RE mm	n min ⁻¹	Vf mm/min	a _p mm	a _e mm	n min ⁻¹	Vf mm/min	a _p mm	a _e mm	n min ⁻¹	Vf mm/min	a _p mm	a _e mm
1	R0.5	40000	3520	0.05	0.04	40000	3360	0.05	0.04	40000	3200	0.05	0.04
1.5	R0.75	40000	4400	0.06	0.06	40000	4200	0.06	0.06	38200	3820	0.06	0.06
2	R1	39000	6000	0.07	0.08	39800	5850	0.07	0.08	28600	4010	0.07	0.08
2.5	R1.25	36900	6500	0.08	0.10	31800	5350	0.08	0.10	22900	3660	0.08	0.10
3	R1.5	30700	6770	0.09	0.12	26500	5570	0.09	0.12	19100	3820	0.09	0.12
4	R2	23000	6600	0.10	0.14	19900	5430	0.10	0.14	14300	3720	0.10	0.14
5	R2.5	18400	6900	0.12	0.16	15900	5680	0.12	0.16	11400	3890	0.12	0.16
6	R3	15300	6770	0.13	0.18	13200	5570	0.13	0.18	9500	3430	0.13	0.18
8	R4	11500	7110	0.15	0.20	9900	5850	0.15	0.20	7100	2860	0.15	0.20
10	R5	9200	7110	0.16	0.22	7900	5850	0.16	0.22	5700	2750	0.16	0.22
12	R6	7600	6770	0.18	0.25	6600	5570	0.18	0.25	4700	2670	0.18	0.25

Material		Gehärteter Stahl											
		58 – 62 HRC				63 – 66 HRC				67 – 70 HRC			
DC mm	RE mm	n min ⁻¹	Vf mm/min	a _p mm	a _e mm	n min ⁻¹	Vf mm/min	a _p mm	a _e mm	n min ⁻¹	Vf mm/min	a _p mm	a _e mm
1	R0.5	40000	2240	0.05	0.04	40000	1790	0.04	0.03	39800	1420	0.03	0.02
1.5	R0.75	31800	2220	0.06	0.06	28600	1600	0.05	0.04	26500	1180	0.03	0.04
2	R1	23800	2340	0.07	0.08	21400	1680	0.06	0.06	19900	1240	0.04	0.05
2.5	R1.25	19100	2140	0.08	0.10	17100	1540	0.06	0.08	15900	1140	0.04	0.06
3	R1.5	15900	2220	0.09	0.12	14300	1600	0.07	0.09	13200	1180	0.05	0.08
4	R2	11900	2170	0.10	0.14	10700	1560	0.08	0.11	9900	1150	0.06	0.09
5	R2.5	9500	2270	0.12	0.16	8500	1630	0.09	0.13	7900	1210	0.07	0.10
6	R3	7900	2220	0.13	0.18	7100	1600	0.10	0.14	6600	1180	0.07	0.12
8	R4	5900	2340	0.15	0.20	5300	1680	0.12	0.16	4900	1240	0.09	0.13
10	R5	4700	2340	0.16	0.22	4200	1680	0.13	0.18	3900	1240	0.10	0.14
12	R6	3900	1780	0.18	0.25	3500	1280	0.14	0.20	3300	950	0.11	0.16

USLB 2000 VHM-Kugelfräser

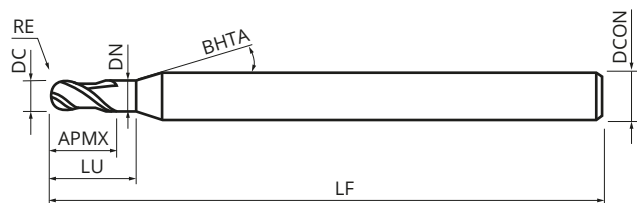
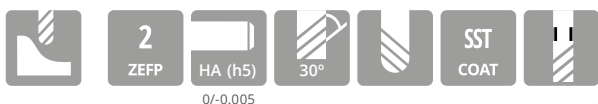

- Zum Schrumpfen und Vorschlichten in vorgehärtetem und gehärtetem Stahl von 30 bis 70 HRC

DC	Toleranzen	
1 - 6	0/-0.015 DC-TOL	±0.01 RE
8 - 12	0/-0.02 DC-TOL	±0.01 RE

ABMESSUNGEN

Artikelnummer (WGR. 9810)	DC mm	RE mm	APMX mm	LU mm	DN mm	BHTA °	LF mm	DCON mm	ZEFP
USLB 2010-025-4	1	0.5	0.8	2.5	0.95	16	50	4	2
USLB 2010-025-6	1	0.5	0.8	2.5	0.95	16	50	6	2
USLB 2015-040-6	1.5	0.75	1.2	4	1.45	16	50	6	2
USLB 2020-050-6	2	1	1.6	5	1.95	16	50	6	2
USLB 2025-060-6	2.5	1.25	2	6	2.4	16	50	6	2
USLB 2030-080-6	3	1.5	2.4	8	2.9	16	70	6	2
USLB 2040-100-6	4	2	3.2	10	3.9	16	70	6	2
USLB 2050-100-6	5	2.5	4	10	4.9	16	80	6	2
USLB 2060-150-6	6	3	4.8	15	5.9	-	80	6	2
USLB 2080-200-8	8	4	8	20	7.9	-	80	8	2
USLB 2100-200-10	10	5	10	20	9.9	-	100	10	2
USLB 2120-250-12	12	6	12	25	11.9	-	100	12	2

SCHNITTDATEN – SCHRUPPEN

Material	Legierter Stahl				(Vor-)gehärteter Stahl			
	HRC 25 - 34				HRC 35 - 44			
DC mm	n min ⁻¹	Vf mm/min	a _p mm	a _e mm	n min ⁻¹	Vf mm/min	a _p mm	a _e mm
1	40570	1390	0.10	0.40	41400	1180	0.10	0.40
1.5	39530	1650	0.14	0.50	40340	1380	0.12	0.45
2	32770	2240	0.22	0.96	29460	1680	0.20	0.09
2.5	26220	2190	0.26	1.10	26750	1780	0.23	1.10
3	21850	2280	0.32	1.44	19640	1720	0.30	1.32
4	16390	2330	0.43	1.91	14730	1740	0.40	1.76
5	13110	2340	0.54	2.40	11780	1750	0.05	2.20
6	10920	2300	0.65	2.88	9820	1680	0.59	2.64
8	8190	2320	0.86	3.84	7360	1740	0.79	3.51
10	6550	2240	1.08	4.80	5890	1680	0.99	4.40
12	5460	2180	1.30	5.76	4910	1630	1.19	5.28

Material	Gehärteter Stahl											
	HRC 45 - 54				HRC 55 - 64				HRC 65 - 70			
DC mm	n min ⁻¹	Vf mm/min	a _p mm	a _e mm	n min ⁻¹	Vf mm/min	a _p mm	a _e mm	n min ⁻¹	Vf mm/min	a _p mm	a _e mm
1	41400	940	0.09	0.35	39810	760	0.07	0.32	23890	360	0.07	0.32
1.5	32910	1130	0.12	0.40	26540	760	0.09	0.42	15920	360	0.09	0.42
2	24680	1130	0.18	0.80	19900	760	0.14	0.64	11940	360	0.14	0.64
2.5	19750	1090	0.23	1.10	15920	760	0.18	0.75	9550	450	0.18	0.75
3	16450	1160	0.27	1.20	13270	780	0.22	0.96	7960	360	0.22	0.96
4	12340	1170	0.36	1.60	9950	790	0.29	1.25	5970	370	0.29	1.25
5	9870	1160	0.45	2.00	7960	790	0.36	1.60	4780	380	0.36	1.60
6	8230	1160	0.54	2.40	6630	780	0.43	1.90	3980	370	0.43	1.90
8	6170	1160	0.72	3.20	4980	780	0.56	2.55	2990	370	0.56	2.55
10	4940	1130	0.90	4.00	3980	760	0.72	3.20	2390	360	0.72	3.20
12	4110	1090	1.08	4.80	3320	730	0.86	3.80	1990	350	0.86	3.80

SCHNITTDATEN – SCHLICHTEN

Material	Legierter Stahl				(Vor-)gehärteter Stahl			
	HRC 25 - 34				HRC 35 - 44			
DC mm	n min ⁻¹	Vf mm/min	a _p mm	a _e mm	n min ⁻¹	Vf mm/min	a _p mm	a _e mm
1	40570	1310	0.06	0.07	41400	1100	0.06	0.07
1.5	39530	1500	0.08	0.09	40340	1300	0.08	0.09
2	39790	2570	0.09	0.10	31850	1690	0.09	0.10
2.5	28710	2180	0.10	0.11	25480	1600	0.10	0.11
3	23930	2230	0.11	0.12	21230	1730	0.11	0.12
4	17950	22850	0.13	0.14	15920	1750	0.13	0.14
5	14360	2260	0.14	0.16	12740	1770	0.14	0.16
6	11960	2250	0.16	0.18	10620	1750	0.16	0.18
8	8970	2220	0.18	0.20	7960	1660	0.18	0.20
10	7180	2180	0.21	0.23	6370	1690	0.21	0.23
12	5980	2050	0.23	0.25	5310	1820	0.23	0.25

Material	Gehärteter Stahl											
	HRC 45 - 54				HRC 55 - 64				HRC 65 - 70			
DC mm	n min ⁻¹	Vf mm/min	a _p mm	a _e mm	n min ⁻¹	Vf mm/min	a _p mm	a _e mm	n min ⁻¹	Vf mm/min	a _p mm	a _e mm
1	41400	1100	0.06	0.07	41400	870	0.06	0.07	35030	600	0.06	0.07
1.5	36090	1170	0.08	0.09	29720	960	0.08	0.09	23350	670	0.08	0.09
2	27070	1440	0.09	0.10	22290	1100	0.09	0.10	17520	800	0.09	0.10
2.5	21660	1360	0.10	0.11	17830	1080	0.10	0.11	14010	800	0.10	0.11
3	18050	1470	0.11	0.12	14860	1130	0.11	0.12	11680	820	0.11	0.12
4	13540	1490	0.13	0.14	11150	1140	0.13	0.14	8760	830	0.13	0.14
5	10830	1500	0.14	0.16	8920	1150	0.14	0.16	7010	830	0.14	0.16
6	9020	1490	0.16	0.18	7430	1130	0.16	0.18	5840	820	0.16	0.18
8	6770	1410	0.18	0.20	5570	1060	0.18	0.20	4380	820	0.18	0.20
10	5410	1440	0.21	0.23	4460	1100	0.21	0.23	3500	800	0.21	0.23
12	4510	1380	0.23	0.25	3720	1060	0.23	0.25	2920	780	0.23	0.25



5xD
APMX



6537
DIN



m7
DC-TOL

SST
COAT

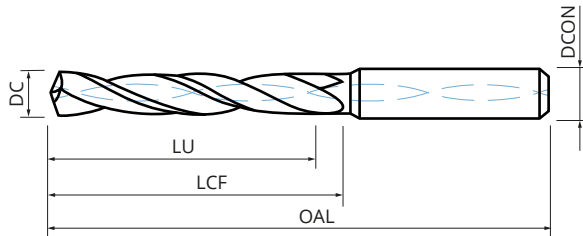

- Zur Anwendung in Stahl bis 45 HRC, rostfreiem Stahl und Titan sowie in Nichteisenmetall

ABMESSUNGEN

Artikelnummer (WGR. 9813)	DC mm	LU mm	LCF mm	DCON mm	OAL mm
SSTD 050300-HA	3	23.5	28	6	66
SSTD 050330-HA	3.3	23.1	28	6	66
SSTD 050340-HA	3.4	22.9	28	6	66
SSTD 050350-HA	3.5	22.8	28	6	66
SSTD 050370-HA	3.7	22.5	28	6	66
SSTD 050380-HA	3.8	30.3	36	6	74
SSTD 050400-HA	4	30	36	6	74
SSTD 050420-HA	4.2	29.7	36	6	74
SSTD 050430-HA	4.3	29.6	36	6	74
SSTD 050450-HA	4.5	29.3	36	6	74
SSTD 050465-HA	4.65	29.1	36	6	74
SSTD 050470-HA	4.7	29	36	6	74
SSTD 050480-HA	4.8	36.8	44	6	82
SSTD 050500-HA	5	36.5	44	6	82
SSTD 050510-HA	5.1	36.4	44	6	82
SSTD 050520-HA	5.2	36.2	44	6	82
SSTD 050550-HA	5.5	35.8	44	6	82
SSTD 050555-HA	5.55	35.7	44	6	82
SSTD 050560-HA	5.6	35.6	44	6	82
SSTD 050580-HA	5.8	35.3	44	6	82
SSTD 050600-HA	6	35	44	6	82
SSTD 050650-HA	6.5	43.3	53	8	91
SSTD 050660-HA	6.6	43.1	53	8	91
SSTD 050680-HA	6.8	42.8	53	8	91
SSTD 050690-HA	6.9	42.7	53	8	91
SSTD 050700-HA	7	42.5	53	8	91
SSTD 050750-HA	7.5	41.8	53	8	91
SSTD 050780-HA	7.8	41.3	53	8	91
SSTD 050800-HA	8	41	53	8	91
SSTD 050850-HA	8.5	48.3	61	10	103
SSTD 050860-HA	8.6	48.1	61	10	103
SSTD 050880-HA	8.8	47.8	61	10	103

ABMESSUNGEN

Artikelnummer (WGR. 9813)	DC mm	LU mm	LCF mm	DCON mm	OAL mm
SSTD 050900-HA	9	47.5	61	10	103
SSTD 050950-HA	9.5	46.8	61	10	103
SSTD 050980-HA	9.8	46.3	61	10	103
SSTD 051000-HA	10	46	61	10	103
SSTD 051020-HA	10.2	55.7	71	12	118
SSTD 051030-HA	10.3	55.6	71	12	118
SSTD 051050-HA	10.5	55.3	71	12	118
SSTD 051080-HA	10.8	54.8	71	12	118
SSTD 051100-HA	11	54.5	71	12	118
SSTD 051150-HA	11.5	53.8	71	12	118
SSTD 051180-HA	11.8	53.3	71	12	118
SSTD 051200-HA	12	53	71	12	118
SSTD 051250-HA	12.5	58.3	77	14	124
SSTD 051300-HA	13	57.5	77	14	124
SSTD 051350-HA	13.5	56.8	77	14	124
SSTD 051400-HA	14	56	77	14	124

Weitere Abmessungen und
HB-Schaft auf Anfrage.

SCHNITTDATEN

Material		Dc	3	4	5	6	8	10	12	14
		Vc m/min	fn mm/U	fn mm/U	fn mm/U	fn mm/U	fn mm/U	fn mm/U	fn mm/U	fn mm/U
Stahl	legiert	100 - 120	0.07	0.09	0.11	0.14	0.17	0.22	0.25	0.29
rostfreier Stahl	ferritisch	60 - 70	0.05	0.07	0.09	0.11	0.12	0.13	0.15	0.17
	martensitisch	40 - 55	0.05	0.07	0.09	0.11	0.12	0.13	0.15	0.17
	austenitisch	55 - 65	0.06	0.08	0.10	0.12	0.12	0.14	0.16	0.18
Superlegierung	Titan	40 - 55	0.03	0.05	0.06	0.07	0.09	0.12	0.13	0.15
Nichteisen Metall	Al-Legierung < 10% Si	200 - 220	0.16	0.22	0.25	0.28	0.30	0.32	0.34	0.37
	Al-Legierung > 10% Si	155 - 180	0.15	0.21	0.24	0.27	0.29	0.31	0.33	0.36
	Andere	105 - 125	0.12	0.16	0.21	0.24	0.26	0.28	0.30	0.33

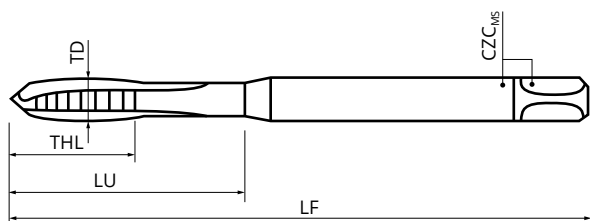

- Zur universellen Anwendung in Stahl, rostfreiem Stahl, Guss, Kupfer und Aluminium
- HSSE-PM Durchgangsgewindebohrer bis 3 x D
- Schafttoleranz h9

ABMESSUNGEN

Artikelnummer (WGR. 9815)	TDZ mm	TP mm	THL mm	LU mm	LF mm	CZC _{MS} mm	DIN
TTM2	M2	0.4	9	-	45	2.8 x 2.1	DIN 371 29.70
TTM2.5	M2.5	0.45	9	14	50	2.8 x 2.1	DIN 371 29.10
TTM3	M3	0.5	10	18	56	3.5 x 2.7	DIN 371 24.50
TTM4	M4	0.7	12	21	63	4.5 x 3.4	DIN 371 24.10
TTM5	M5	0.8	14	25	70	6 x 4.9	DIN 371 25.80
TTM6	M6	1	16	30	80	6 x 4.9	DIN 371 26.20
TTM8	M8	1.25	18	35	90	8 x 6.2	DIN 371 32.30
TTM10	M10	1.5	20	39	100	10 x 8	DIN 371 36.90
TTM12	M12	1.75	24	-	110	9 x 7	DIN 376 49.30
TTM16	M16	2	27	-	110	12 x 9	DIN 376 68.20
TTM20	M20	2.5	32	-	140	16 x 12	DIN 376 105.40

SCHNITTDATEN

Material	Werkstoffbeispiel	N/mm ²	HB	V _c m/min
Unlegierter Baustahl / Weicheisen	1.0330	100 – 450	90 – 120	20 – 30
Baustahl / Einsatzstahl	1.0038	300 – 700	80 – 150	20 – 30
Bau- / Kohlenstoffstahl C < 0.45%	1.0503	400 – 950	172 – 242	20 – 30
Kohlenstoffstahl C > 0.45%	1.7225	450 – 950	217 – 237	15 – 35
Legierter Stahl / Hochlegierter Stahl	1.2379	800 – 1250	235 – 370	10 – 20
Stahl ferritisch und martensitisch	1.4028	450 – 1200	260 – 425	6 – 12
Stahl austenitisch, aust.-ferritisch	1.4571	400 – 950	150 – 215	6 – 12
Stahl austenitisch, aust.-ferritisch und ferritisch	1.4568	850 – 1250	250 – 455	3 – 8
Temperguss	5.4101	300 – 700	100 – 200	15 – 25
Aluminium Si ≤ 0.5%	3.0205	100 – 700	30 – 200	15 – 35
Aluminium Si ≤ 6%	3.2151	150 – 700	45 – 200	15 – 40
Aluminium Si > 6%	3.2381	150 – 900	45 – 265	15 – 40

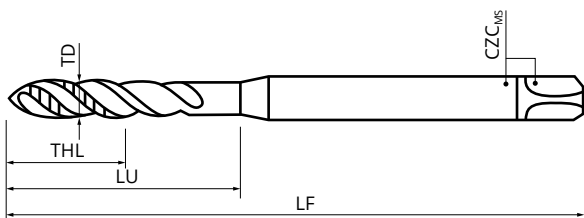

- Zur universellen Anwendung in Stahl, rostfreiem Stahl, Guss, Kupfer und Aluminium
- HSSE-PM Sacklochgewindebohrer bis 3xD
- Schafttoleranz h9

ABMESSUNGEN

Artikelnummer (WGR. 9815)	TDZ mm	TP mm	THL mm	LU mm	LF mm	CZC _{Ms} mm	DIN
TBM3	M3	0.5	7	18	56	3.5 x 2.7	DIN 371
TBM4	M4	0.7	8	21	63	4.5 x 3.4	DIN 371
TBM5	M5	0.8	9	25	70	6 x 4.9	DIN 371
TBM6	M6	1	10	30	80	6 x 4.9	DIN 371
TBM8	M8	1.25	13	35	90	8 x 6.2	DIN 371
TBM10	M10	1.5	15	39	100	10 x 8	DIN 371
TBM12	M12	1.75	18	-	110	9 x 7	DIN 376
TBM16	M16	2	20	-	110	12 x 9	DIN 376
TBM20	M20	2.5	25	-	140	16 x 12	DIN 376

SCHNITTDATEN

Material	Werkstoffbeispiel	N/mm ²	HB	V _c m/min
Unlegierter Baustahl / Weicheisen	1.0330	100 – 450	90 – 120	20 – 30
Baustahl / Einsatzstahl	1.0038	300 – 700	80 – 150	20 – 30
Bau- / Kohlenstoffstahl C < 0.45%	1.0503	400 – 950	172 – 242	20 – 30
Kohlenstoffstahl C > 0.45%	1.7225	450 – 950	217 – 237	15 – 35
Legierter Stahl / Hochlegierter Stahl	1.2379	800 – 1250	235 – 370	10 – 20
Stahl ferritisch und martensitisch	1.4028	450 – 1200	260 – 425	6 – 12
Stahl austenitisch, aust.-ferritisch	1.4571	400 – 950	150 – 215	6 – 12
Stahl austenitisch, aust.-ferritisch und ferritisch	1.4568	850 – 1250	250 – 455	3 – 6
Temperguss	5.4101	300 – 700	100 – 200	15 – 25
Aluminium Si ≤ 0.5%	3.0205	100 – 700	30 – 200	15 – 35
Aluminium Si ≤ 6%	3.2151	150 – 700	45 – 200	15 – 40
Aluminium Si > 6%	3.2381	150 – 900	45 – 265	15 – 40



**NEUE*
MODELLE**

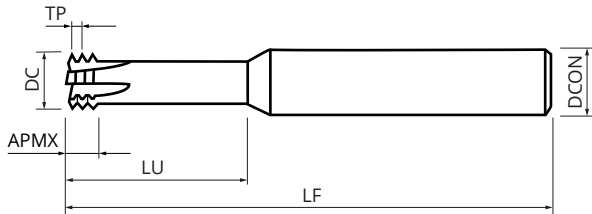

- Zur Anwendung in Stahl bis HRC 63, rostfreiem Stahl, Guss und Superlegierungen
- Zirkulargewindefräsen bis 2.5 x D Gewindetiefe
- LINKSSCHNEIDEND

ABMESSUNGEN

Artikelnummer (WGR. 9823)	FTDZ	TP mm	DC mm	APMX mm	LU mm	LF mm	DCON mm	ZEFP
CDTMLM2	M2 - M2.3	0.4	1.46	1.2	5.8	58	6	4
CDTMLM2.5	M2.5 - M2.6	0.45	1.9	1.35	7.2	58	6	4
CDTMLM3	M3 - MF4	0.5	2.33	1.5	8.25	58	6	4
CDTMLM4	M4	0.7	3.1	2.1	11.2	58	6	4
CDTMLM5	M5	0.8	3.9	2.4	13.7	58	6	4
CDTMLM6	M6 - MF8	1	4.7	3	17.6	58	6	4
CDTMLM8	M8 - MF10	1.25	6.4	3.75	22	62	8	4
CDTMLM10	M10 - MF12	1.5	8.1	4.5	27.5	76	10	4
CDTMLM12	M12	1.75	9.8	5.25	32.8	76	10	4
CDTMLM14	M14 - M16	2	11.5	6	38.2	88	12	4
CDTMLM16	M16 - MF18	2	13.4	6	43.2	92	14	4
* CDTMLM20	M20 - MF22	2.5	15	7.5	56.5	108	16	4
CDTMLMF8X075	MF8	0.75	6.8	2.25	22	62	8	4
CDTMLMF10X100	MF10	1	8.5	3	27.5	76	10	4

Artikelnummer (WGR. 9823)	FTDZ	TP mm	DC mm	APMX mm	LU mm	LF mm	DCON mm	ZEFP
CDTMLG1/8	G1/8"	28	8.1	2.72	27	76	10	4
CDTMLG1/4	G1/4"	19	11	4.01	36	88	12	4
CDTMLG3/8	G3/8"	19	14.4	4.01	44	96	16	4
* CDTMLG1/2	G1/2"	14	17.95	5.44	56	108	18	4

SCHNITTDATEN

Material	Werkstoffnr.	Beispiel	Festigkeit N/mm ²	Vc m/min	Durchmesserbereich Dc - fz								
					<2.0 mm/Z	<3.0 mm/Z	<4.0 mm/Z	<5.0 mm/Z	<6.0 mm/Z	<8.0 mm/Z	<10.0 mm/Z	<12.0 mm/Z	<16.0 mm/Z
Allgemeiner Baustahl	1.0037	St37-2	≤ 500	85	0.013	0.015	0.02	0.024	0.032	0.039	0.047	0.052	0.056
	1.006	St60-2	≤ 850	70	0.012	0.014	0.019	0.022	0.03	0.036	0.043	0.048	0.052
Automatenstahl	1.0718	9SMnPb28	≤ 850	75	0.012	0.014	0.019	0.022	0.03	0.036	0.043	0.048	0.052
	1.0728	60S20	≤ 1000	65	0.011	0.013	0.018	0.02	0.028	0.033	0.039	0.044	0.048
Unlegierter Vergütungsstahl	1.0501	C35	≤ 700	85	0.013	0.015	0.02	0.024	0.032	0.039	0.047	0.052	0.056
	1.1191	Ck45	≤ 850	75	0.012	0.014	0.019	0.022	0.03	0.036	0.043	0.048	0.052
	1.1221	Ck60	≤ 1000	65	0.011	0.013	0.018	0.02	0.028	0.033	0.039	0.044	0.048
Legierter Vergütungsstahl	1.1167	36Mn5	≤ 1000	70	0.011	0.013	0.018	0.02	0.028	0.033	0.039	0.044	0.048
	1.6582	34CrNiMo6	≤ 1200	60	0.01	0.012	0.017	0.019	0.026	0.031	0.036	0.041	0.045
Unlegierter Einsatzstahl	1.1141	Ck15	≤ 750	85	0.013	0.015	0.02	0.024	0.032	0.039	0.047	0.052	0.056
Leg. Einsatzstahl	1.7131	16MnCr5	≤ 1000	70	0.011	0.013	0.018	0.02	0.028	0.033	0.039	0.044	0.048
	1.7147	20MnCr5	≤ 1200	60	0.01	0.012	0.017	0.019	0.026	0.031	0.036	0.041	0.045
Nitrierstahl	1.8506	34CrAlS5	≤ 1000	70	0.011	0.013	0.018	0.02	0.028	0.033	0.039	0.044	0.048
	1.8519	31CrMoV9	≤ 1200	60	0.01	0.012	0.017	0.019	0.026	0.031	0.036	0.041	0.045
Werkzeugstahl	1.2067	100Cr6	≤ 850	70	0.012	0.014	0.019	0.022	0.03	0.036	0.043	0.048	0.052
	1.2316	X36CrMo17	≤ 1100	65	0.011	0.013	0.018	0.02	0.028	0.033	0.039	0.044	0.048
	1.2436	X210CrW12	≤ 1800	50	0.01	0.012	0.017	0.019	0.026	0.031	0.036	0.041	0.045
Rostfreier Stahl	1.4301	X8CrNiS18 9 1)	≤ 700	45	0.012	0.014	0.019	0.022	0.03	0.036	0.043	0.048	0.052
	1.4021	X5CrNi18 10 2)	≤ 700	40	0.011	0.013	0.018	0.02	0.028	0.033	0.039	0.044	0.048
	-	X20Cr5 13 3)	≤ 1100	35	0.01	0.012	0.017	0.019	0.026	0.031	0.036	0.041	0.045
Gusseisen	0.6025	GG-25	≤ 180 HwB	85	0.017	0.019	0.024	0.03	0.038	0.045	0.055	0.06	0.064
	0.706	GGG-60	≤ 260 HB	80	0.015	0.017	0.022	0.026	0.034	0.04	0.048	0.053	0.057
	0.8165	GTS-65	-	75	0.011	0.013	0.018	0.02	0.028	0.033	0.039	0.044	0.048
Titanlegierung	3.7114	TiAl5Sn2,5	≤ 850	45	0.011	0.013	0.018	0.02	0.028	0.033	0.039	0.044	0.048
	3.7164	TiAl6V4	≤ 1200	35	0.01	0.012	0.017	0.019	0.026	0.031	0.036	0.041	0.045
Gehärteter Stahl	-	-	≤ 44 HRC	55	0.009	0.013	0.016	0.02	0.027	0.033	0.04	0.044	0.048
	-	-	≤ 54 HRC	50	0.008	0.012	0.015	0.018	0.025	0.03	0.036	0.04	0.044
	-	-	≤ 63 HRC	40	0.007	0.011	0.014	0.017	0.023	0.028	0.033	0.037	0.041

- 1) geschwefelt
 2) austenitisch
 3) martensitisch

Der angegebene Vorschub bezieht sich auf die Fräser-Aussenbahn:
Vf Mittelpunkt = fz × z × n × (D - DC) / D

SST ZIRKULARBOHRGEWINDEFÄSEN

Arbeitsschritte	Ablauf
1	Werkzeug fährt auf Startposition zentrisch über die Gewindeposition
2	Beginn mit zirkularer Fräsbewegung
3	Zirkulares Bohrgewindefräsen von oben nach unten
4	Bis zur gewünschten Gewindetiefe
5	Beenden des Gewindefräsvorganges mit einer Ausfahrtschleife
6	Verfahren auf Startposition und beenden des Bearbeitungsvorgangs

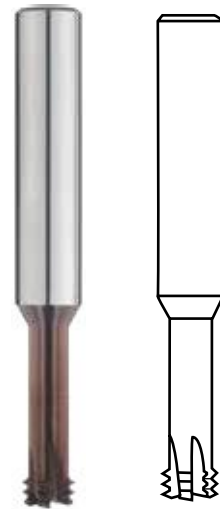

LINKSSCHNEIDEND!



KERNLOCH DURCHMESSER

TDZ	TP	D1 min	D1 max	Bohrdurchmesser
M2	0.4	1.583	1.658	1.6
M2.5	0.45	2.013	2.138	2.1
M3	0.5	2.459	2.599	2.5
M4	0.7	3.242	3.422	3.3
M5	0.8	4.134	4.334	4.2
M6	1	4.917	5.153	5
M8	1.25	6.647	6.912	6.8
M10	1.5	8.376	8.676	8.5
M12	1.75	10.106	10.441	10.2
M16	2	13.835	14.210	14
M20	2.5	17.294	17.774	17.5

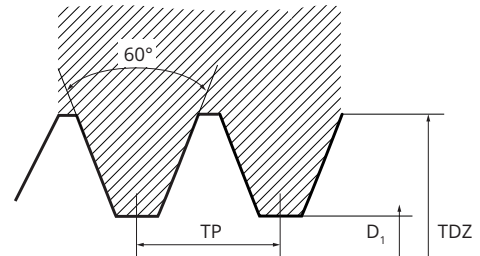

Metrisches ISO-Gewinde nach DIN 13 und DIN ISO 965-1

BERECHNUNGSFORMEL

Parameter	Formel	Einheit
Drehzahl	$n = \frac{v_c \times 1000}{D_c \times \pi}$	[min ⁻¹]
Spezif. Schnittkraft	$k_c = k_{c1.1} \times \left[\frac{p^2}{2 \times Z \times L_f} \right]^{m_c}$	
Drehmoment Gewindebohrer	$M_d = \frac{k_c \times D_N \times p^2}{8000} \times \left[\frac{L_c}{D_N} \right]^\delta \times \left[1.112 - \frac{Y}{100} \right]$	[Nm]
Leistung am Gewindebohrer	$P = \frac{M_d \times n}{9500 \times \eta}$	[kW]

D1	Kernloch Durchmesser	[mm]
TDZ	GewindegröÙe	[mm]
TP	Gewindesteigung	[mm]
n	Drehzahl	[min ⁻¹]
v_c	Schnittgeschwindigkeit	[m/min]
D_c	Schneidendurchmesser	[mm]
D_N	Gewinde-Nenn Durchmesser	[mm]
P	Gewindesteigung	[mm]
z	Anzahl Nuten	
L_c	Gewindetiefe	[mm]
L_f	Anschnittlänge	[mm]
Y	Spanwinkel	
δ	Korrekturfaktor (0.55 auf 0.25)	
k_c	Spezifische Schnittkraft	[N/mm ²]
F_c	Schnittkraft	[N]
M_d	Drehmoment	[Nm]
P	Leistung am Gewindebohrer	[kW]
η	Wirkungsgrad Maschine (< 1)	

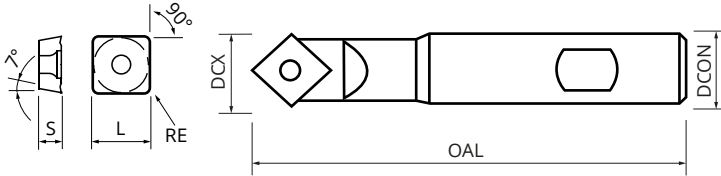

- Vielseitiges einsetzbares Multifunktionswerkzeug mit Wendeplatten
- Bearbeitungsmöglichkeiten: Anbohren, Entgraten und Gravieren
- SOGT: Speziell ausgespitze Wendeplatten für Anbohr-Operationen. Wird auch für feine Gravier Operationen empfohlen

ABMESSUNGEN HALTER

Artikelnummer (WGR. 3030)	DCX mm	DCON mm	APMX mm	OAL mm	SIG °	ZEFP
SST-MTH-K-S16-90	13	16	6.5	100	90	1

ABMESSUNGEN WENDEPLATTE

Artikelnummer (WGR. 3031)	L mm	IC mm	S mm	RE mm
SOMT11T308 SSTP20	11.00	10.87	3.97	0.80
SOGT11T303 SSTM20	11.00	10.87	3.97	0.30

SCHNITTDATEN

Material		Vc m/min	fz mm/U	
			SOMT11T308 SSTP20	SOGT11T303 SSTM20
Stahl	niedrig legiert	120 - 150	0.04 - 0.08	0.05 - 0.10
	legiert	100 - 120	0.03 - 0.07	0.05 - 0.10
	hochlegiert	60 - 100	0.03 - 0.06	0.04 - 0.08
rostfreier Stahl	ferritisch	100 - 150	0.04 - 0.07	0.03 - 0.06
	austenitisch	60 - 120	0.03 - 0.06	0.03 - 0.07
Guss	Grauguss	80 - 120	0.05 - 0.08	0.05 - 0.08
	Sphäroguss	70 - 110	0.04 - 0.08	0.04 - 0.08
	Temperguss	90 - 150	0.05 - 0.10	0.05 - 0.10

Verfahren

Gravieren

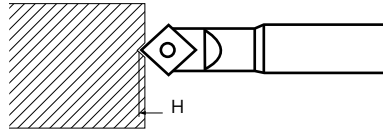

max. H = 0.7 mm

NC-Anbohren

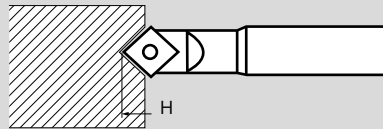

max. H = 5 mm

Fasenfräsen

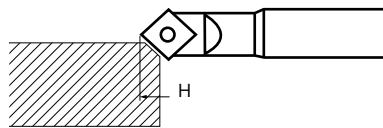

max. H = 7 mm

FF060-Z VHM-Fasenfräser 60°

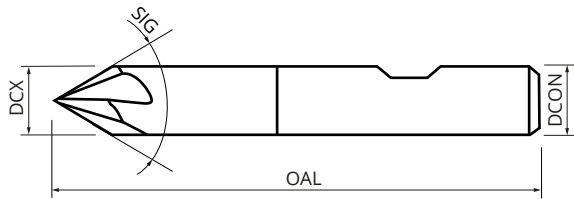

- Zur universellen Anwendung in Stahl, rostfreiem Stahl, Guss, Superlegierungen und Nichteisenmetallen
- Nicht für Bohr-Operationen geeignet

ABMESSUNGEN

Artikelnummer (WGR. 9827)	DC mm	OAL mm	DCON mm	SIG °	ZEFP
FF060040-Z4*	4	54	4	60	4
FF060060-Z4	6	57	6	60	4
FF060080-Z4	8	63	8	60	4
FF060100-Z4	10	72	10	60	4

* mit HA-Schaft

SCHNITTDATEN

Material	DC	≤ 4.0	4.1 - 8.0	8.1 - 10.0
	Vc m/min	fz mm/Z	fz mm/Z	fz mm/Z
Unlegierter Baustahl	80 - 120	0.015	0.03	0.04
Legierter Stahl / Hochlegierter Stahl	40 - 80	0.01	0.02	0.03
Rostfreier Stahl	40 - 80	0.01	0.02	0.03
Guss	80 - 120	0.015	0.04	0.04
Superlegierung	40 - 80	0.008	0.015	0.02
Nichteisen Metall	120 - 150	0.015	0.03	0.04

FF090-Z VHM-Fasenfräser 90°

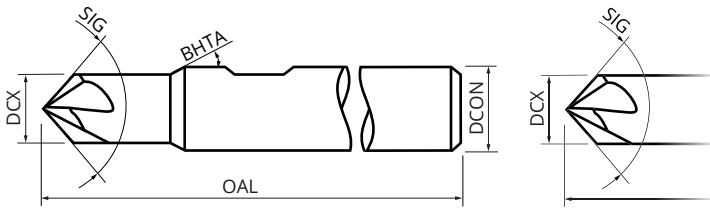

gilt für DCX ≥ 3

gilt für DCX < 3

- Zur universellen Anwendung in Stahl, rostfreiem Stahl, Guss, Superlegierungen und Nichteisenmetallen
- Nicht für Bohr-Operationen geeignet

ABMESSUNGEN

Artikelnummer (WGR. 9827)	DCX mm	LU mm	OAL mm	DCON mm	SIG °	BHTA °	ZEFP
FF090010-Z3*	1	5	38	3	90	22.5	3
FF090020-Z3*	2	5	38	3	90	22.5	3
FF090030-Z4*	3	-	38	3	90	-	4
FF090040-Z4*	4	-	54	4	90	-	4
FF090060-Z4	6	-	57	6	90	-	4
FF090080-Z4	8	-	63	8	90	-	4
FF090100-Z4	10	-	72	10	90	-	4
FF090120-Z4	12	-	83	12	90	-	4
FF090160-Z5	16	-	92	16	90	-	5
FF090200-Z6	20	-	104	20	90	-	6

* mit HA-Schaft

SCHNITTDATEN

Material	DC	≤ 2.0	2.1 - 4.0	4.1 - 8.0	8.1 - 12.0	≥ 12.1
	Vc m/min	fz mm/Z	fz mm/Z	fz mm/Z	fz mm/Z	fz mm/Z
Unlegierter Baustahl	80 - 120	0.005	0.015	0.03	0.04	0.06
Legierter Stahl / Hochlegierter Stahl	40 - 80	0.003	0.01	0.02	0.03	0.05
Rostfreier Stahl	40 - 80	0.003	0.01	0.02	0.03	0.05
Guss	80 - 120	0.005	0.015	0.04	0.04	0.06
Superlegierung	40 - 80	0.002	0.008	0.015	0.02	0.03
Nichteisen Metall	120 - 150	0.005	0.015	0.03	0.04	0.06

FF120-Z VHM-Fasenfräser 120°

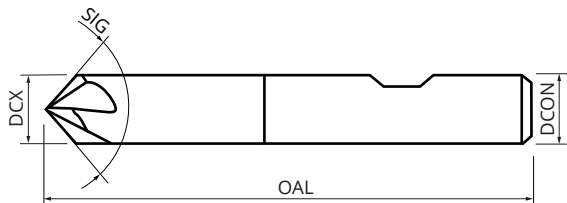

- Zur universellen Anwendung in Stahl, rostfreiem Stahl, Guss, Superlegierungen und Nichteisenmetallen
- Nicht für Bohr-Operationen geeignet

ABMESSUNGEN

Artikelnummer (WGR. 9827)	DCX mm	OAL mm	DCON mm	SIG °	ZEFP
FF120040-Z4*	4	54	4	120	4
FF120060-Z4	6	57	6	120	4
FF120080-Z4	8	63	8	120	4
FF120100-Z4	10	72	10	120	4

* mit HA-Schaft

SCHNITTDATEN

Material	DC	≤ 4.0	4.1 - 8.0	8.1 - 10.0
	Vc m/min	fz m/min	fz mm/Z	fz mm/Z
Unlegierter Baustahl	80 - 120	0.015	0.03	0.04
Legierter Stahl / Hochlegierter Stahl	40 - 80	0.01	0.02	0.03
Rostfreier Stahl	40 - 80	0.01	0.02	0.03
Guss	80 - 120	0.015	0.04	0.04
Superlegierung	40 - 80	0.008	0.015	0.02
Nichteisen Metall	120 - 150	0.015	0.03	0.04



3-4

ZEFP



HA (h6)

SST

COAT

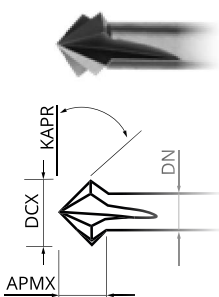

DCX ≤ 6 mm Stirn spitz zulaufend

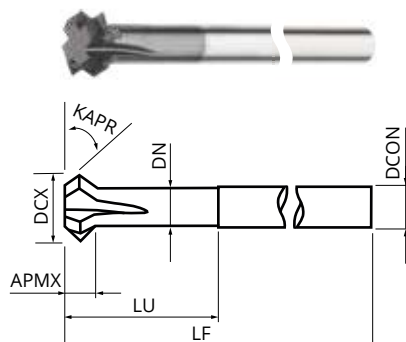

DCX ≥ 8 mm Spitze abgeflacht



- Zur universellen Anwendung in Stahl, rostfreiem Stahl, Guss, Superlegierungen und Nichteisenmetallen
- VHM-Fasenfräser 45° für Vor- und Rückwärtsbearbeitung

ABMESSUNGEN

Artikelnummer (WGR. 7972)	DCX mm	APMX mm	LU mm	DN mm	LF mm	DCON mm	KAPR °	ZEFP
VRE090020	2	1.4	8	1.2	100	6	45	3
VRE090030	3	2.0	8	2.0	100	6	45	4
VRE090040	4	3.0	10	2.0	100	6	45	4
VRE090060	6	4.0	15	4.0	100	6	45	4
VRE090080	8	3.2	-	-	100	6	45	4
VRE090100	10	4.3	-	-	100	6	45	4
VRE090120	12	5.0	-	-	100	6	45	4
VRE090160	16	8.0	-	-	100	10	45	4

SCHNITTDATEN

Material	DC	≤ 4.0	4.1 - 8.0	8.1 - 12.0	≥ 12.1
	Vc m/min	fz m/min	fz m/min	fz m/min	fz m/min
Unlegierter Baustahl	70 - 90	0.010	0.016	0.020	0.026
Legierter Stahl / Hochlegierter Stahl	50 - 70	0.008	0.013	0.017	0.018
Rostfreier Stahl	30 - 50	0.008	0.013	0.017	0.018
Guss	60 - 80	0.010	0.016	0.020	0.023
Superlegierung	30 - 45	0.005	0.010	0.015	0.015
Nichteisen Metall	120 - 150	0.010	0.016	0.020	0.023



4

ZEFP



HA (h6)

SST

COAT

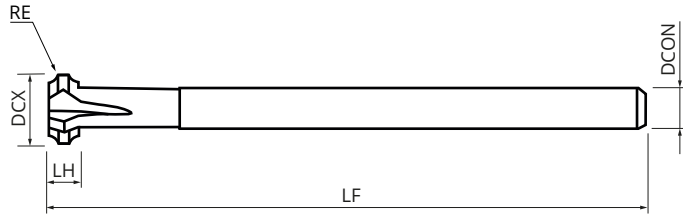

P

M

K

S

N

- Zur universellen Anwendung in Stahl, rostfreiem Stahl, Guss, Superlegierung und Nichteisenmetallen

ABMESSUNGEN

Artikelnummer (WGR. 7972)	DCX mm	RE mm	LH mm	LF mm	DCON mm	ZEFP
RVRE002080	8	0.2	2	100	6	4
RVRE003080	8	0.3	2	100	6	4
RVRE004080	8	0.4	2	100	6	4
RVRE005080	8	0.5	2	100	6	4
RVRE008100	10	0.8	4	100	6	4
RVRE010100	10	1.0	4	100	6	4
RVRE012100	10	1.2	4	100	6	4
RVRE015100	10	1.5	4	100	6	4

SCHNITTDATEN

Material	RE	0.2	0.3	0.4	0.5	0.8	1.0	1.2	1.5
	Vc m/min	fz mm/Z	fz mm/Z	fz mm/Z	fz mm/Z	fz mm/Z	fz mm/Z	fz mm/Z	fz mm/Z
Unlegierter Baustahl	70 - 90	0.050	0.040	0.030	0.025	0.023	0.023	0.020	0.020
Legierter Stahl / Hochlegierter Stahl	50 - 70	0.037	0.030	0.025	0.020	0.018	0.018	0.015	0.015
Rostfreier Stahl	30 - 50	0.037	0.030	0.025	0.020	0.018	0.018	0.015	0.015
Guss	60 - 80	0.050	0.040	0.030	0.025	0.023	0.023	0.020	0.020
Superlegierung	30 - 45	0.037	0.030	0.025	0.020	0.018	0.018	0.015	0.015
Nichteisen Metall	120 - 150	0.050	0.040	0.030	0.025	0.023	0.023	0.020	0.020

KSE090 VHM-Kegelsenker 90°



3
ZEFP

HA (h6)

SST
COAT

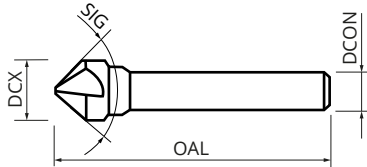

- Universell einsetzbarer VHM-Kegelsenker
- Ø 4.3 mm aus Vollhartmetall
- Ø 6.3 – 31 mm Kopf aus Vollhartmetall, Schaft gelötet

ABMESSUNGEN

ArtNr. (WGR. 7972)	DCX mm	DCON mm	OAL mm	SIG °	ZEFP
KSE090043	4.3	6	50	90°	3
KSE090063	6.3	6	51	90°	3
KSE090083	8.3	6	52	90°	3
KSE090104	10.4	6	53	90°	3
KSE090124	12.4	8	55	90°	3
KSE090165	16.5	10	58	90°	3
KSE090205	20.5	10	61	90°	3
KSE090250	25.0	10	64	90°	3
KSE090310	31.0	10	68	90°	3

SCHNITTDATEN

Material		Dc	3	5	10	15	20	25	30
		Vc m/min	fn mm/U	fn mm/U	fn mm/U	fn mm/U	fn mm/U	fn mm/U	fn mm/U
Stahl	unlegiert	60 - 70	0.08	0.09	0.11	0.13	0.15	0.18	0.22
	niedriglegiert	55 - 65	0.07	0.08	0.09	0.11	0.14	0.17	0.20
Rostfreier Stahl		20 - 25	0.05	0.06	0.07	0.09	0.11	0.14	0.17
Guss		40 - 50	0.08	0.09	0.11	0.13	0.15	0.18	0.22
Nichteisen Metall	Al-Legierung	110 - 130	0.08	0.09	0.11	0.13	0.15	0.18	0.22
	Kunststoff	200 - 230	0.09	0.10	0.12	0.15	0.18	0.21	0.24

KSE090-UG

HSS-Kegelsenker ungleich geteilt 90°



3
ZEFP

HA (h6)



SST
COAT

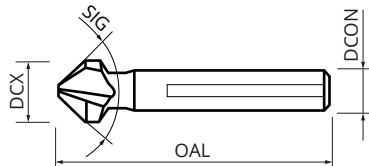

- Universell einsetzbarer Hochleistungs-HSS-Kegelsenker mit 3-Flächenschaft
- Ungleich geteilt

ABMESSUNGEN

ArtNr. (WGR. 7972)	DCX mm	DCON mm	OAL mm	SIG °	ZEFP
KSE090043-UG	4.3	4	40	90°	3
KSE090063-UG	6.3	5	45	90°	3
KSE090083-UG	8.3	6	50	90°	3
KSE090104-UG	10.4	6	50	90°	3
KSE090124-UG	12.4	8	56	90°	3
KSE090165-UG	16.5	10	60	90°	3
KSE090205-UG	20.5	10	63	90°	3
KSE090250-UG	25.0	10	67	90°	3
KSE090310-UG	31.0	12	71	90°	3

SCHNITTDATEN

Material		Dc	3	5	10	15	20	25	30
		Vc m/min	fn mm/U	fn mm/U	fn mm/U	fn mm/U	fn mm/U	fn mm/U	fn mm/U
Stahl	unlegiert	13 - 20	0.11	0.13	0.18	0.21	0.25	0.27	0.31
	niedriglegiert	8 - 15	0.08	0.10	0.14	0.17	0.10	0.24	0.27
Rostfreier Stahl		4 - 6	0.05	0.06	0.07	0.09	0.10	0.11	0.12
Guss		15 - 23	0.07	0.09	0.11	0.13	0.16	0.20	0.23
Nichteisen Metall	Al-Legierung	35 - 50	0.12	0.15	0.19	0.21	0.23	0.27	0.31
	Kunststoff	15 - 25	0.11	0.13	0.16	0.19	0.21	0.26	0.30

SST
COAT

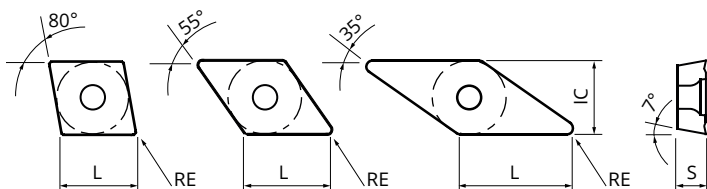

- Wendeplatte mit extra scharfer Geometrie und spezieller Beschichtung
- Hervorragend geeignet für Schlichtoperationen in Stahl, rostfreiem Stahl und Superlegierungen
- Gut geeignet für Schruppoperationen in Nicht-eisenmetallen

ABMESSUNGEN

Artikelnummer (WGR. 9824)	L mm	IC mm	S mm	RE mm
CCGT060202-AL-B	6.2	6.35	2.38	0.2
CCGT060204-AL-B	6.2	6.35	2.38	0.4
CCGT09T302-AL-B	9.67	9.53	3.97	0.2
CCGT09T304-AL-B	9.67	9.53	3.97	0.4
CCGT09T308-AL-B	9.67	9.53	3.97	0.8
CCGT120402-AL-B	12.9	12.7	4.76	0.2
CCGT120404-AL-B	12.9	12.7	4.76	0.4
CCGT120408-AL-B	12.9	12.7	4.76	0.8

Artikelnummer (WGR. 9824)	L mm	IC mm	S mm	RE mm
DCGT070202-AL-B	7.5	6.35	2.38	0.2
DCGT070204-AL-B	7.5	6.35	2.38	0.4
DCGT11T301-AL-B	11.63	9.53	3.97	0,1
DCGT11T302-AL-B	11.63	9.53	3.97	0.2
DCGT11T304-AL-B	11.63	9.53	3.97	0.4
DCGT11T308-AL-B	11.63	9.53	3.98	0.8

Artikelnummer (WGR. 9824)	L mm	IC mm	S mm	RE mm
VCGT110301-AL-B	11.07	6.35	3.18	0.1
VCGT110302-AL-B	11.07	6.35	3.18	0.2
VCGT110304-AL-B	11.07	6.35	3.18	0.4
VCGT160402-AL-B	16.61	9.53	4.76	0.2
VCGT160404-AL-B	16.61	9.53	4.76	0.4
VCGT160408-AL-B	16.61	9.53	4.76	0.8

SCHNITTDATEN

Material	Stahl			Rostfreier Stahl			Superlegierung		
	Schichten			Schichten			Schichten		
Artikel	Vc m/min	fn mm/U	ap mm	Vc m/min	fn mm/U	ap mm	Vc m/min	fn mm/U	ap mm
CCGT060202-AL-B	250 - 800	0.10 - 0.20	0.2 - 2.0	300 - 1200	0.05 - 0.12	0.05 - 0.1	90 - 250	0.04 - 0.10	0.05 - 0.1
CCGT060204-AL-B	250 - 800	0.13 - 0.24	0.2 - 2.0	300 - 1200	0.05 - 0.12	0.05 - 0.1	90 - 250	0.06 - 0.12	0.05 - 0.1
CCGT09T302-AL-B	250 - 800	0.10 - 0.20	0.2 - 2.0	300 - 1200	0.05 - 0.12	0.05 - 0.1	90 - 250	0.04 - 0.10	0.05 - 0.1
CCGT09T304-AL-B	250 - 800	0.10 - 0.25	0.2 - 2.5	300 - 1200	0.08 - 0.20	0.1 - 0.2	90 - 250	0.06 - 0.15	0.1 - 0.2
CCGT09T308-AL-B	250 - 800	0.15 - 0.35	0.3 - 3.0	300 - 1200	0.10 - 0.25	0.1 - 0.3	90 - 250	0.08 - 0.20	0.1 - 0.3
CCGT120402-AL-B	250 - 800	0.10 - 0.20	0.1 - 2.5	300 - 1200	0.05 - 0.12	0.05 - 0.1	90 - 250	0.04 - 0.10	0.05 - 0.1
CCGT120404-AL-B	250 - 800	0.10 - 0.25	0.2 - 3.0	300 - 1200	0.08 - 0.20	0.1 - 0.2	90 - 250	0.06 - 0.15	0.1 - 0.2
CCGT120408-AL-B	250 - 800	0.15 - 0.35	0.3 - 3.5	300 - 1200	0.10 - 0.25	0.1 - 0.3	90 - 250	0.08 - 0.20	0.1 - 0.3
DCGT070202-AL-B	250 - 800	0.10 - 0.20	0.2 - 2.0	300 - 1200	0.05 - 0.12	0.05 - 0.1	90 - 250	0.04 - 0.10	0.05 - 0.1
DCGT070204-AL-B	250 - 800	0.13 - 0.24	0.2 - 2.0	300 - 1200	0.05 - 0.12	0.05 - 0.1	90 - 250	0.06 - 0.12	0.05 - 0.1
DCGT11T301-AL-B	250 - 800	0.10 - 0.20	0.1 - 1.5	300 - 1200	0.05 - 0.12	0.05 - 0.1	90 - 250	0.01 - 0.05	0.05 - 0.1
DCGT11T302-AL-B	250 - 800	0.10 - 0.20	0.2 - 2.0	300 - 1200	0.05 - 0.12	0.05 - 0.1	90 - 250	0.04 - 0.10	0.05 - 0.1
DCGT11T304-AL-B	250 - 800	0.10 - 0.25	0.2 - 3.0	300 - 1200	0.08 - 0.20	0.1 - 0.2	90 - 250	0.06 - 0.15	0.1 - 0.2
DCGT11T308-AL-B	250 - 800	0.15 - 0.35	0.3 - 3.5	300 - 1200	0.10 - 0.25	0.1 - 0.3	90 - 250	0.08 - 0.20	0.1 - 0.3
VCGT110301-AL-B	250 - 800	0.10 - 0.20	0.1 - 1.5	300 - 1200	0.05 - 0.12	0.05 - 0.1	90 - 250	0.01 - 0.05	0.05 - 0.1
VCGT110302-AL-B	250 - 800	0.10 - 0.20	0.2 - 2.0	300 - 1200	0.05 - 0.12	0.05 - 0.1	90 - 250	0.04 - 0.10	0.05 - 0.1
VCGT110304-AL-B	250 - 800	0.13 - 0.24	0.2 - 2.0	300 - 1200	0.05 - 0.12	0.05 - 0.1	90 - 250	0.06 - 0.12	0.05 - 0.1
VCGT160402-AL-B	250 - 800	0.10 - 0.20	0.2 - 2.0	300 - 1200	0.05 - 0.12	0.05 - 0.1	90 - 250	0.04 - 0.10	0.05 - 0.1
VCGT160404-AL-B	250 - 800	0.10 - 0.25	0.2 - 2.5	300 - 1200	0.08 - 0.20	0.1 - 0.2	90 - 250	0.06 - 0.15	0.1 - 0.2
VCGT160408-AL-B	250 - 800	0.15 - 0.35	0.3 - 3.0	300 - 1200	0.10 - 0.25	0.1 - 0.3	90 - 250	0.08 - 0.20	0.1 - 0.3

Material	Aluminium					
	Schruppen			Schichten		
Artikel	Vc m/min	fn mm/U	ap mm	Vc m/min	fn mm/U	ap mm
CCGT060202-AL-B	80 - 220	0.04 - 0.10	0.05 - 0.1	50 - 140	0.04 - 0.10	0.05 - 0.1
CCGT060204-AL-B	80 - 220	0.06 - 0.12	0.05 - 0.1	50 - 140	0.06 - 0.12	0.05 - 0.1
CCGT09T302-AL-B	80 - 220	0.04 - 0.10	0.05 - 0.1	50 - 140	0.04 - 0.10	0.05 - 0.1
CCGT09T304-AL-B	80 - 220	0.06 - 0.15	0.1 - 0.2	50 - 140	0.06 - 0.15	0.1 - 0.2
CCGT09T308-AL-B	80 - 220	0.08 - 0.20	0.1 - 0.3	50 - 140	0.08 - 0.20	0.1 - 0.3
CCGT120402-AL-B	80 - 220	0.04 - 0.10	0.05 - 0.1	50 - 140	0.04 - 0.10	0.05 - 0.1
CCGT120404-AL-B	80 - 220	0.06 - 0.15	0.1 - 0.2	50 - 140	0.06 - 0.15	0.1 - 0.2
CCGT120408-AL-B	80 - 220	0.08 - 0.20	0.1 - 0.3	50 - 140	0.08 - 0.20	0.1 - 0.3
DCGT070202-AL-B	80 - 220	0.04 - 0.10	0.05 - 0.1	50 - 140	0.04 - 0.10	0.05 - 0.1
DCGT070204-AL-B	80 - 220	0.06 - 0.12	0.05 - 0.1	50 - 140	0.06 - 0.12	0.05 - 0.1
DCGT11T301-AL-B	80 - 220	0.01 - 0.05	0.05 - 0.1	50 - 140	0.01 - 0.05	0.05 - 0.1
DCGT11T302-AL-B	80 - 220	0.04 - 0.10	0.05 - 0.1	50 - 140	0.04 - 0.10	0.05 - 0.1
DCGT11T304-AL-B	80 - 220	0.06 - 0.15	0.1 - 0.2	50 - 140	0.06 - 0.15	0.1 - 0.2
DCGT11T308-AL-B	80 - 220	0.08 - 0.20	0.1 - 0.3	50 - 140	0.08 - 0.20	0.1 - 0.3
VCGT110301-AL-B	80 - 220	0.01 - 0.05	0.05 - 0.1	50 - 140	0.01 - 0.05	0.05 - 0.1
VCGT110302-AL-B	80 - 220	0.04 - 0.10	0.05 - 0.1	50 - 140	0.04 - 0.10	0.05 - 0.1
VCGT110304-AL-B	80 - 220	0.06 - 0.12	0.05 - 0.1	50 - 140	0.06 - 0.12	0.05 - 0.1
VCGT160402-AL-B	80 - 220	0.04 - 0.10	0.05 - 0.1	50 - 140	0.04 - 0.10	0.05 - 0.1
VCGT160404-AL-B	80 - 220	0.06 - 0.15	0.1 - 0.2	50 - 140	0.06 - 0.15	0.1 - 0.2
VCGT160408-AL-B	80 - 220	0.08 - 0.20	0.1 - 0.3	50 - 140	0.08 - 0.20	0.1 - 0.3

Berechnungsformeln

FRÄSEN

Parameter	Formel	Einheit
Drehzahl	$n = \frac{v_c \times 1000}{D_c \times \pi}$	[min ⁻¹]
Schnittgeschwindigkeit	$v_c = \frac{D_c \times \pi \times n}{1000}$	[m/min]
Vorschubgeschwindigkeit	$v_f = f_z \times z \times n$	[mm/min]
Zahnvorschub	$f_z = \frac{v_f}{z \times n}$	[mm/z]

$$h_m = \frac{\left(114,7 \times f_z \times \sin \kappa \times \left(\frac{a_e}{D_c} \right) \right)}{\varphi_s}$$

$$f_z = \frac{h_m \times \varphi_s}{114,7 \times f_z \times \sin \kappa \times \left(\frac{a_e}{D_c} \right)}$$

**Mittlere Spannungs-
dicke**

$$\text{oder } h_m \cong f_z \times \sqrt{\frac{a_e}{D_c}} \quad [\text{mm}]$$

$$f_z = \frac{h_m}{\sqrt{\frac{a_e}{D_c}}}$$

als Näherungsformel für $\frac{a_e}{D_c} < 30\%$

FRÄSEN

Parameter	Formel	Einheit
	bei zentraler Stellung des Fräasers	
	$\varphi_s \cong 2 \times \arcsin \left(\frac{a_e}{D_c} \right)$	
Eingriffswinkel	bei außermittiger Stellung des Fräasers	[°]
	$\varphi_s \cong 90^\circ + \arcsin \frac{a_e - \left(\frac{D_c}{2} \right)}{\left(\frac{D_c}{2} \right)}$	
Spezif. Schnittkraft	$k_c = \frac{1 - 0,01 \times y_0}{h_m^{m_c}} \times k_{c1,1}$	[N/mm ²]
Leistungsbedarf	$P_{\text{mot}} = \frac{Q \times k_c}{60000 \times \eta}$	[kW]
Zeitspanvolumen	$Q = \frac{a_e \times a_p \times v_f}{1000}$	[cm ³ /min]

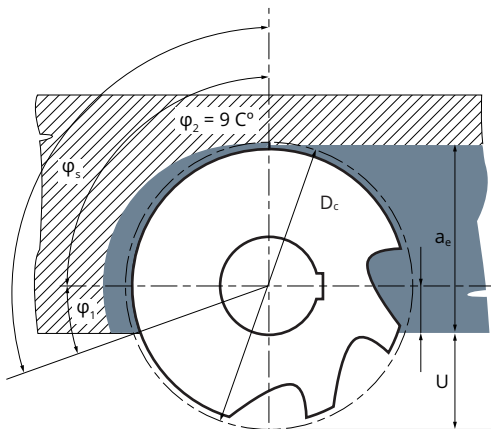
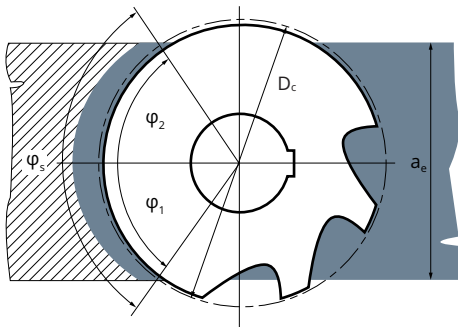
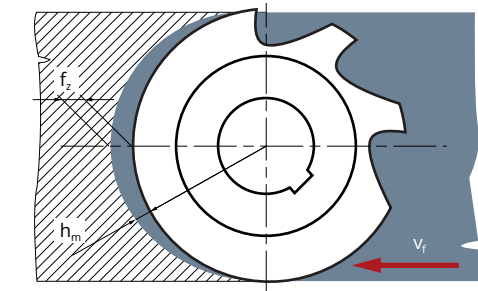

n	Drehzahl	min ⁻¹
D_c	Schneidendurchmesser	mm
z	Zähnezahl	
v_c	Schnittgeschwindigkeit	m/min
v_f	Vorschubgeschwindigkeit	mm/min
f_z	Zahnvorschub	mm
Q	Zeitspanvolumen	cm ³ /min
h	Spandicke	mm
κ	Einstellwinkel	°
T_c	Bearbeitungszeit	min
U	Überstand	mm
a_e	Schnittbreite	mm
a_p	Schnitttiefe	mm
y	Gegenlaufeingriff	mm
P_{mot}	Antriebsleistung	kW
h_m	Mittlere Spanungsdicke	mm
η	Wirkungsgrad Maschine (0.7 – 0.95)	
φ_s	Eingriffswinkel	°
φ₁	Bereich Gegenlauffräsen	°
φ₂	Bereich Gleichlauffräsen	°
k_c	Spezifische Schnittkraft	N/mm ²
k_{c1.1}	Spezifische Schnittkraft für 1 mm ² Spanquerschnitt	N/mm ²
m_c	Anstieg der k _c -Kurve	

SIX SIGMA TOOLS
CUTTING TOOL EXPERTS



- Die Schnittdaten sind Richtwerte. Je nach Aufspannung und Maschine sind die Daten entsprechend anzupassen.
- Anwendung dieser Schnittdaten auf eigene Verantwortung. Alle Angaben ohne Gewähr, Modell-, Farb- und Preisänderungen vorbehalten.
- Es gelten unsere AGB´s (www.sixsigmatools.com/AGB-GmbH.pdf).
- Technische Änderungen ohne Vorankündigung möglich. Es gelten unsere allgemeinen Geschäftsbedingungen. | Drucklegung 2024

SIX SIGMA TOOLS GmbH

Rebgartenweg 30
79576 Weil am Rhein
Deutschland

Tel.: +49 7621 154 26 00

E-Mail: info@sixsigmatools.de

Web: www.sixsigmatools.com
