

SIX SIGMA TOOLS® TECHNOLOGY

EDITION 05.3

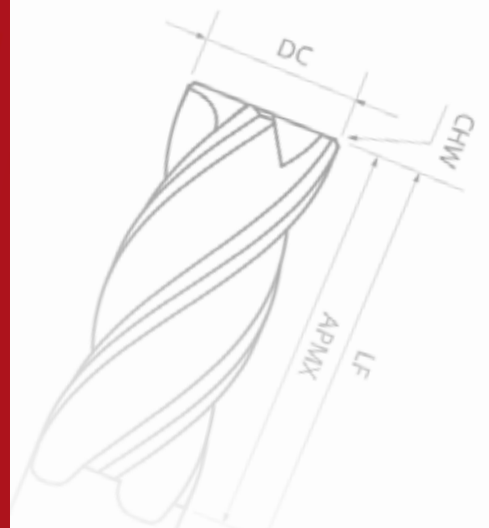

$$v_c = \frac{D_c \times \pi \times n}{1000}$$

$$f = f_z \times Z$$

$$v_f = f \times n$$



NEUIGKEITEN UND ERWEITERUNGEN UNSERES SORTIMENTS FÜR EFFIZIENTE ZER- SPANUNGSPROZESSE

*Nouveautés et extension
de notre panel pour
des processus d'usinage
plus efficaces*

















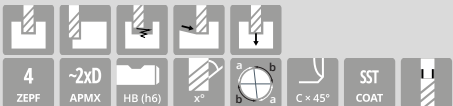

Icons Icônes

P Stahl <i>Acier</i>	M Rostfreier Stahl <i>Acier inoxydable</i>	S Superlegierung und Titan <i>Superalliage et titane</i>
K Guss <i>Fonte</i>	H Gehärteter Stahl <i>Acier trempé</i>	N NE-Metalle <i>Métaux non ferreux</i>
P Stahl (geeignet) <i>Acier (adapté pour)</i>	M Rostfreier Stahl (geeignet) <i>Acier inoxydable (adapté pour)</i>	S Superlegierung und Titan (geeignet) <i>Superalliage et titane (adapté pour)</i>
K GUSS (geeignet) <i>Fonte (adapté pour)</i>	H Gehärteter Stahl (geeignet) <i>Acier trempé (adapté pour)</i>	N NE-Metalle (geeignet) <i>Métaux non ferreux (adapté pour)</i>
Vollnutfräsen <i>Rainurage</i>	Umfangsfraesen <i>Contournage</i>	HSC Hochgeschwindigkeitsfräsen <i>Fraisage à haute vitesse</i>
Trochoidalfräsen <i>Fraisage trochoïdale</i>	Planfräsen <i>Surfaçage</i>	3D-Fräsen <i>Fraisage 3D</i>
Helixfräsen <i>Fraisage hélicoïdal</i>	Ramping <i>Fraisage en rampe</i>	Bohren <i>Perçage</i>
Fasenfräsen <i>Chanfreiner</i>	Vor- und Rückwärts Fasenfräsen <i>Fraisage de chanfreins avant et arrière</i>	Vollbohren <i>Perçage</i>
Flachbohren <i>Perçage à fond plat</i>	Senken <i>Chanfreinage</i>	Zentrierbohren <i>Centrage</i>
Durchgangsloch <i>Trou traversant</i>	Sackloch <i>Trou borgne</i>	
Ungleiche Teilung <i>Pas inégal</i>	Ungleicher Drallwinkel <i>Hélice inégale</i>	Drallwinkel <i>Angle d'hélice</i>
Spitzenwinkel <i>Angle de pointe</i>	Beschichtung <i>Revêtement</i>	UN-COAT Unbeschichtet <i>Non revêtu</i>
Zylinderschaft <i>Queue cylindrique</i>	Weldonschaft <i>Queue avec méplat</i>	Halsfreistellung <i>Détalonnage</i>
Spanteiler <i>Brise-copeaux</i>	Backtaper <i>Avec arrête de coupe en contre dépouille</i>	Zentrale Innenkühlung <i>Refroidissement par le centre</i>
Radiale Innenkühlung <i>Refroidissement interne radiale</i>	Innenkühlung <i>Refroidissement interne</i>	Zähnezahl <i>Nombre de dents</i>
Gewindetoleranz <i>Tolérance de filetage</i>	Durchmessertoleranz <i>Tolérance de diamètre</i>	Fase 45° <i>Chanfrein 45°</i>
Eckenradius <i>Rayon d'angle</i>	Scharfkantig <i>Arrêtes vives</i>	Kugelfräser <i>Fraise hémisphérique</i>
DIN-Norm <i>Norme DIN</i>	Verhältnis Nutzlänge/Durchmesser <i>Rapport longueur utile/diamètre</i>	Anschnittform <i>Entrée forme</i>
Schrupp-Profil <i>Profil d'ébauche</i>	Längenangabe <i>Spécification de longueur</i>	Metrisch <i>Métrique</i>
Metrisch-fein <i>Métrique fin</i>	Whitworth <i>Whitworth</i>	

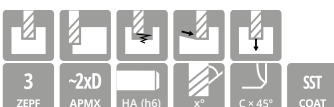
ae	Radiale Zustellung	<i>Largueur de coupe radiale</i>
ap	Axiale Zustellung	<i>Profondeur de coupe axiale</i>
APMX	Maximale Schnitttiefe	<i>Profondeur de coupe maximale</i>
BHTA	Körperkegeleinstellwinkel	<i>Demi angle du corps</i>
CHW	Eckenfasenbreite	<i>Largeur du renfort d'arrête</i>
CZCMS	Aufnahmegröße, maschinenseitig	<i>Taille de l'attachement, côté machine</i>
DC	Werkzeugdurchmesser	<i>Diamètre de l'outil</i>
DCON	Aufnahmedurchmesser, werkstückseitig	<i>Diamètre de queue, côté pièce</i>
DCX	Schneidendurchmesser, max.	<i>Diamètre de coupe, max.</i>
DN	Halsdurchmesser	<i>Diamètre détalonné</i>
FTDZ	Größe des Gewindedurchmessers	<i>Dimension du filetage</i>
fz	Vorschub pro Zahn	<i>Avance par dent</i>
h	Maximal verbleibendes Aufmaß	<i>Sur-épaisseur maximale restante</i>
IC	Inkreisdurchmesser	<i>Diamètre du cercle intérieur</i>
KAPR	Winkel Werkzeugschneidkante	<i>Angle d'arrête de coupe de l'outil</i>
L	Schneidkantenlänge	<i>Longueur de coupe</i>

LF	Funktionslänge	<i>Longueur fonctionnelle</i>
LH	Kopflänge	<i>Longueur de la tête</i>
LU	Maximale Nutzlänge	<i>Longueur utile maximale</i>
n	Drehzahl	<i>Vitesse de rotation</i>
RE	Eckenradius	<i>Rayon d'arrête</i>
RE_{CAM}	Programmier-Radius	<i>Rayon de programmation</i>
S	Schneidplattendicke	<i>Épaisseur de plaquette</i>
SIG	Spitzenwinkel	<i>Angle de pointe</i>
TDZ	Gewindegröße	<i>Taille du filet</i>
THL	Länge Schneidteil	<i>Longueur de la partie coupant</i>
TOL	Toleranz	<i>Tolérance</i>
TP	Gewindesteigung	<i>Pas du filetage</i>
TPI	Gewindegänge je Inch	<i>Filets par pouce</i>
ULDR	Verhältnis Nutzlänge / Durchmesser	<i>Rapport longueur utile / diamètre</i>
Vc	Schnittgeschwindigkeit	<i>Vitesse de Coupe</i>
Vf	Bahngeschwindigkeit	<i>Vitesse de balayage</i>
ZEFP	Anzahl wirksamer Schneiden, umfangseitig	<i>Nombre de dents périphériques effectives</i>











Inhalt Sommaire

Artikel Article	Beschreibung Description	Material und Durchmesserbereich Matériaux et gamme de diamètres	Bearbeitungen und werkzeugbezogene Eigenschaften Usinage et propriétés de l'outil	S. P.
TROCHOIDALFRÄSER <i>Fraises trochoïdales</i>				
RCRH	 VHM-Trochoidalfräser <i>Fraise en carbure pour l'usinage en trochoïdale</i>	P M K Ø 3 – 20		08
RCRL	 VHM-Trochoidalfräser <i>Fraise en carbure pour l'usinage en trochoïdale</i>	P M K S Ø 4 – 20		12
RCRC	 VHM-Trochoidalfräser <i>Fraise en carbure pour l'usinage en trochoïdale</i>	P M S H Ø 8 – 16		16
HOCHLEISTUNGSFRÄSER MIT SCHUTZFASE <i>Fraises haute performance avec protection d'arêtes</i>				
NEU <i>nouveau</i>	 GSXMT 4000 VHM-Schaftfräser <i>Fraise cylindrique en carbure</i>	P M K S Ø 3 – 20		20
GSXMF 4000	 VHM-Schaftfräser FE <i>FE fraise cylindrique en carbure</i>	P K H Ø 1 – 20		22
GSXMV 4000	 VHM-Schaftfräser VA <i>VA fraise cylindrique en carbure</i>	P M S Ø 3 – 20		24
GSXMV 3000	 VHM-Passfedernutfräser <i>Fraise à rainurer en carbure</i>	P M K S N Ø 1 – 16		26
GSXLV 4000	 VHM-Schaftfräser mit kleinen Fasen <i>Fraise cylindrique avec protection d'arêtes en carbure</i>	P M S Ø 3 – 20		30
GCMT 5000	 VHM-Schaftfräser – lang <i>Fraise cylindrique en carbure – longue</i>	P M S Ø 10 – 16		32
GCST 5000	 VHM-Schaftfräser – kurz <i>Fraise cylindrique en carbure – courte</i>	P M S Ø 6 – 12		34



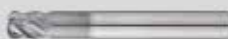

Inhalt Sommaire

Artikel Article	Beschreibung Description	Material und Durchmesserbereich Matériaux et gamme de diamètres	Bearbeitungen und werkzeugbezogene Eigenschaften Usinage et propriétés de l'outil	S. P.
--------------------	-----------------------------	--	---	----------



HOCHLEISTUNGSFRÄSER MIT ECKENRADIUS *Fraises haute performance torique*

NEU <i>nouveau</i>	 GRXFE 4000 VHM-Torusfräser <i>Fraise torique en carbure</i>	P K H Ø 3 – 20		36
NEUE MODELLE <i>nouveaux modèles</i>	 GCRESN 4000 VHM-Torusfräser <i>Fraise torique en carbure</i>	P H K N Ø 3 – 20		38
	 GCRT 4000 VHM-Torusfräser – verstärkter Kern <i>Fraise torique en carbure – renforcée</i>	P M S Ø 6 – 12		42
	 GCRT 5000 VHM-Torusfräser <i>Fraise torique en carbure</i>	P M S Ø 6 – 12		44
	 GCR 4000 VHM-Torusfräser – bis HRC 55 <i>Fraise torique en carbure – jusqu'à 55 HRC</i>	P M S N H Ø 2 – 12	HSC 	46

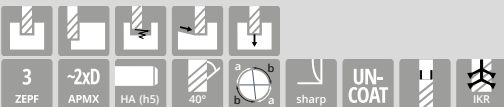
HOCHLEISTUNGSFRÄSER SCHARFKANTIG *Fraises haute performance à arêtes vives*



	 GSSVA 4000 VHM-Schaftfräser VA <i>VA fraise cylindrique en carbure</i>	P M S Ø 2.5 – 12		50
	 GS 4000 VHM-Schaftfräser – bis HRC 55 <i>Fraise cylindrique en carbure – jusqu'à 55 HRC</i>	P H Ø 1 – 10	HSC 	52
	 GSWMN 3000 VHM-Schaftfräser <i>Fraise cylindrique en carbure</i>	N Ø 4 – 12		54

HOCHLEISTUNGSFRÄSER-SCHLICHTFRÄSER *Fraises haute performance pour finition*

NEU <i>nouveau</i>	 FCZM-HP VHM-Präzisions Schlichtfräser < 5 µm <i>Fraise de précision pour finition en carbure</i>	P M K S N Ø 3 – 20		56
---------------------------	---	--	--	----

Artikel Article	Beschreibung Description	Material und Durchmesserbereich Matériaux et gamme de diamètres	Bearbeitungen und werkzeugbezogene Eigenschaften Usinage et propriétés de l'outil	S. P.
--------------------	-----------------------------	--	---	----------

HOCHLEISTUNGSFRÄSER-SCHLICHTFRÄSER *Fraises haute performance pour finition*

NEU <i>nouveau</i>		P H	HSC 4-6 ZEPF HA SST COAT	58
HBCBC	VHM-Tonnenfräser <i>Fraise tonneau en carbure</i>	Ø 5 - 10		
NEU <i>nouveau</i>		P H	HSC 4-6 ZEPF HA SST COAT	62
HBTBC	VHM-Tonnenfräser - tangential <i>Fraise tonneau en carbure - tangentielle</i>	Ø 3 - 10		

HOCHLEISTUNGSFRÄSER MIT SCHRUPP-PROFIL *Fraises haute performance a profil ébauche*

GSXRM 4000		P M S	4 ZEPF ~2xD APMX HB (h6) x° HR TYP C x 45° SST COAT	66
	VHM-Schrupfräser <i>Fraise d'ébauche en carbure</i>	Ø 4 - 20		



HOCHVORSCHUBFRÄSER *Fraises haute avances*

NEUE MODELLE <i>nouveaux modèles</i>		P H	HSC 4-6 ZEPF HA (h5) x° RE SST COAT	68
RHCSN	VHM-Highfeed Fräser <i>Fraise à grande avance en carbure</i>	Ø 1 - 12		











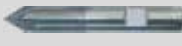

HOCHLEISTUNGSKUGELFRÄSER *Fraises haute performance hémisphérique*

EFLB 4000		P H K	4 ZEPF HA (h5) 40° SST COAT	70
	VHM-Kugelfräser <i>Fraise hémisphérique en carbure</i>	Ø 1 - 12		

GEWINDEWERKZEUGE *Outils a fileter*



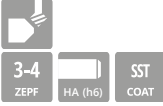





CDTML		P M K S H	4 ZEPF 2.5xD APMX HA SST COAT	72
	VHM-Zirkularbohrergewindefräser <i>Fraise à percer et fileter en carbure</i>			
TTM		P M K N	371 DIN 376 DIN B FORM 6H ISO2 SST COAT	74
	HSSE-PM-Durchgangsgewindebohrer <i>Taraud pour trou passant en HSSE-PM</i>	M2 - M20		
TBM		P M K N	371 DIN 376 DIN C FORM 6H ISO2 SST COAT	76
	HSSE-PM-Sacklochgewindebohrer <i>Taraud pour trou borgne en HSSE-PM</i>	M3 - M20		

Inhalt *Sommaire*

Artikel <i>Article</i>	Beschreibung <i>Description</i>	Material und Durchmesserbereich <i>Matériaux et gamme de diamètres</i>	Bearbeitungen und werkzeugbezogene Eigenschaften <i>Usinage et propriétés de l'outil</i>	S. P.
FASEN- UND SENKWERKZEUGE <i>Outils à chanfreiner et fraises coniques</i>				
NEU <i>nouveau</i>		P M K N S		
SST-MT	Wendeplatten- Multifunktionswerkzeug 90° <i>Outil multifonction à plaquettes 90°</i>	Ø 16		79
		P M K S H		
CT	VHM-Fasenfräser 90° <i>Fraise à chanfreiner 90°</i>	Ø 3 - 10		81
		P M K S N		
FF060	VHM-Fasenfräser 60° <i>Fraise à chanfreiner 60°</i>	Ø 4 - 16		82
		P M K S N		
FF090	VHM-Fasenfräser 90° <i>Fraise à chanfreiner 90°</i>	Ø 1 - 20		83
		P M K S N		
FF120	VHM-Fasenfräser 120° <i>Fraise à chanfreiner 120°</i>	Ø 4 - 20		84
		P M K S N		
VRE	VHM-Vor- und Rückwärts Fasenfräser 45° <i>Fraise biconique 45° en carbure</i>	Ø 2 - 16		85
NEU <i>nouveau</i>		P M K S N		
RVRE	VHM-Vor- und Rückwärts Viertelkreisfräser R0.2 - R1.5 <i>Fraise quart de cercle en carbure en plongeant et en tirant R0.2 - R1.5</i>	Ø 8 - 10		86

Artikel <i>Article</i>	Beschreibung <i>Description</i>	Material und Durchmesserbereich <i>Matériaux et gamme de diamètres</i>	Bearbeitungen und werkzeugbezogene Eigenschaften <i>Usinage et propriétés de l'outil</i>	S. P.
---------------------------	------------------------------------	--	--	----------

DREHWENDEPLATTEN *Plaquettes de tournage*

CCGT	 Drehwendeplatten - beschichtet <i>Plaquettes de tournage - revêtues</i>			88
DCGT	 Drehwendeplatten - beschichtet <i>Plaquettes de tournage - revêtues</i>			88
VCGT	 Drehwendeplatten - beschichtet <i>Plaquettes de tournage - revêtues</i>			88

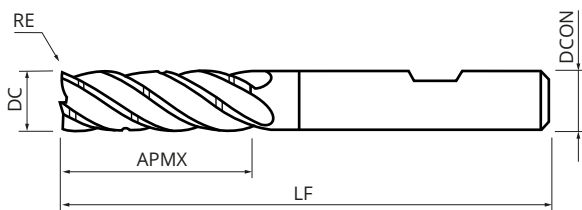

- Zur Anwendung in Stahl, rostfreiem Stahl und Guss *Pour l'utilisation dans l'acier, l'acier inoxydable et la fonte*
- Mit Spanteiler für kurze Späne *Avec brise copeau pour copeaux courts*

ABMESSUNGEN *Dimensions*

Artikelnummer <i>Référence</i> (WGR. 7683)	DC	ULDR	APMX	LF	DCON	RE	ZEPF
	mm		mm	mm	mm	mm	
RCRHL 3030R02	3	4xD	12	57	6	0.2	3
RCRHL 4040R02	4	4xD	16	60	6	0.2	4
RCRHL 4050R02	5	4xD	20	62	6	0.2	4
RCRHL 5060R02	6	4xD	24	70	6	0.2	5
RCRHL 5080R02	8	4xD	32	75	8	0.2	5
RCRHM 5100R02	10	3xD	30	80	10	0.2	5
RCRHL 5100R02	10	4xD	40	90	10	0.2	5
RCRHM 6120R03	12	3xD	36	93	12	0.3	6
RCRHL 6120R03	12	4xD	48	105	12	0.3	6
RCRHX 6120R03	12	5xD	60	112	12	0.3	6
RCRHM 6160R03	16	3xD	48	105	16	0.3	6
RCRHL 6160R03	16	4xD	64	120	16	0.3	6
RCRHX 6160R03	16	5xD	80	140	16	0.3	6
RCRHL 6200R05	20	4xD	80	140	20	0.5	6

SCHNITTDATEN *Données de coupe*

Material <i>Matière</i>		Baustahl <i>Acier de construction</i>							
		3% ae				5% ae		10% ae	
DC mm	ULDR	n min ⁻¹	ap mm	Vf mm/min	ae mm	Vf mm/min	ae mm	Vf mm/min	ae mm
3	4 x D	9600	9	1490	0.09	1150	0.15	720	0.3
4	4 x D	9000	13	2800	0.12	2170	0.2	1350	0.4
5	4 x D	10100	16	4190	0.15	3250	0.25	2020	0.5
6	4 x D	12100	21	9430	0.18	7300	0.3	4540	0.6
8	4 x D	9000	29	11690	0.24	9050	0.4	5630	0.8
10	3 x D	7900	26	9230	0.3	7150	0.5	4450	1
10	4 x D	7200	35	8410	0.3	6520	0.5	4050	1
12	3 x D	6600	35	11720	0.36	9080	0.6	5650	1.2
12	4 x D	6000	43	10660	0.36	8250	0.6	5130	1.2
12	5 x D	5100	52	9060	0.36	7020	0.6	4360	1.2
16	3 x D	4900	46	9920	0.48	7690	0.8	4780	1.6
16	4 x D	4500	57	9110	0.48	7060	0.8	4390	1.6
16	5 x D	3800	69	7700	0.48	5960	0.8	3710	1.6
20	4 x D	3600	72	8410	0.6	6520	1	4050	2

Material <i>Matière</i>		Vergütungsstahl <i>Acier revenu</i>							
		3% ae				5% ae		10% ae	
DC mm	ULDR	n min ⁻¹	ap mm	Vf mm/min	ae mm	Vf mm/min	ae mm	Vf mm/min	ae mm
3	4 x D	8400	9	1040	0.09	810	0.15	500	0.3
4	4 x D	7900	13	2130	0.12	1650	0.2	1020	0.4
5	4 x D	8100	16	3030	0.15	2340	0.25	1460	0.5
6	4 x D	10500	21	6810	0.18	5280	0.3	3280	0.6
8	4 x D	7900	29	6560	0.24	5080	0.4	3160	0.8
10	3 x D	6900	26	7170	0.3	5550	0.5	3450	1
10	4 x D	6300	35	6540	0.3	5070	0.5	3150	1
12	3 x D	5700	35	9060	0.36	7020	0.6	4360	1.2
12	4 x D	5200	43	8260	0.36	6400	0.6	3980	1.2
12	5 x D	4700	52	7470	0.36	5780	0.6	3600	1.2
16	3 x D	4300	46	8040	0.48	6230	0.8	3870	1.6
16	4 x D	3900	57	7290	0.48	5650	0.8	3510	1.6
16	5 x D	3500	69	6540	0.48	5070	0.8	3150	1.6
20	4 x D	3100	72	6280	0.6	4860	1	3020	2

SCHNITTDATEN *Données de coupe*

Material <i>Matière</i>		Hochlegierter Stahl <i>Acier fortement allié</i>							
		3% ae			5% ae		10% ae		
DC mm	ULDR	n min ⁻¹	ap mm	Vf mm/min	ae mm	Vf mm/min	ae mm	Vf mm/min	ae mm
3	4 x D	7000	9	870	0.09	670	0.15	420	0.3
4	4 x D	6400	13	1720	0.12	1330	0.2	830	0.4
5	4 x D	6500	16	2430	0.15	1880	0.25	1170	0.5
6	4 x D	8500	21	5520	0.18	4270	0.3	2660	0.6
8	4 x D	6400	29	5320	0.24	4120	0.4	2560	0.8
10	3 x D	5600	26	5810	0.3	4500	0.5	2800	1
10	4 x D	5100	35	5300	0.3	4100	0.5	2550	1
12	3 x D	4700	35	7470	0.36	5780	0.6	3600	1.2
12	4 x D	4200	43	6670	0.36	5170	0.6	3210	1.2
12	5 x D	3600	52	5720	0.36	4430	0.6	2750	1.2
16	3 x D	3500	46	6540	0.48	5070	0.8	3150	1.6
16	4 x D	3200	57	5980	0.48	4630	0.8	2880	1.6
16	5 x D	2700	69	5050	0.48	3910	0.8	2430	1.6
20	4 x D	2500	72	5060	0.6	3920	1	2440	2

Material <i>Matière</i>		Werkzeugstahl <i>Acier à outil</i>							
		3% ae			5% ae		10% ae		
DC mm	ULDR	n min ⁻¹	ap mm	Vf mm/min	ae mm	Vf mm/min	ae mm	Vf mm/min	ae mm
3	4 x D	7500	9	930	0.09	720	0.15	450	0.3
4	4 x D	6900	13	1860	0.12	1440	0.2	890	0.4
5	4 x D	7100	16	2650	0.15	2050	0.25	1280	0.5
6	4 x D	9300	21	6040	0.18	4670	0.3	2910	0.6
8	4 x D	6900	29	5730	0.24	4440	0.4	2760	0.8
10	3 x D	6100	26	6330	0.3	4910	0.5	3050	1
10	4 x D	5500	35	5710	0.3	4420	0.5	2750	1
12	3 x D	5100	35	8100	0.36	6280	0.6	3900	1.2
12	4 x D	4600	43	7310	0.36	5660	0.6	3520	1.2
12	5 x D	3900	52	6200	0.36	4800	0.6	2980	1.2
16	3 x D	3800	46	7100	0.48	5500	0.8	3420	1.6
16	4 x D	3400	57	6360	0.48	4920	0.8	3060	1.6
16	5 x D	2900	69	5420	0.48	4200	0.8	2610	1.6
20	4 x D	2700	72	5470	0.6	4230	1	2630	2

SCHNITTDATEN *Données de coupe*

Material <i>Matière</i>		Rostfreier Stahl <i>Acier inoxydable</i>							
				3% ae		5% ae		10% ae	
DC mm	ULDR	n min ⁻¹	ap mm	Vf mm/min	ae mm	Vf mm/min	ae mm	Vf mm/min	ae mm
3	4 x D	6900	9	830	0.09	640	0.15	400	0.3
4	4 x D	5700	13	1050	0.12	810	0.2	500	0.4
5	4 x D	6400	16	1770	0.15	1370	0.25	850	0.5
6	4 x D	7600	21	4160	0.18	3220	0.3	2000	0.6
8	4 x D	5700	28	4110	0.24	3180	0.4	1980	0.8
10	3 x D	5000	26	5050	0.3	3910	0.5	2430	1
10	4 x D	4500	34	4540	0.3	3520	0.5	2190	1
12	3 x D	4200	35	5520	0.36	4280	0.6	2660	1.2
12	4 x D	3800	43	5000	0.36	3870	0.6	2410	1.2
12	5 x D	3200	52	4210	0.36	3260	0.6	2030	1.2
16	3 x D	3100	46	5360	0.48	4150	0.8	2580	1.6
16	4 x D	2800	57	4840	0.48	3750	0.8	2330	1.6
16	5 x D	2400	69	4150	0.48	3210	0.8	2000	1.6
20	4 x D	2200	72	4950	0.6	3830	1	2380	2

Material <i>Matière</i>		Guss <i>Fonte</i>							
				3% ae		5% ae		10% ae	
DC mm	ULDR	n min ⁻¹	ap mm	Vf mm/min	ae mm	Vf mm/min	ae mm	Vf mm/min	ae mm
3	4 x D	8900	9	1110	0.09	860	0.15	530	0.3
4	4 x D	8300	13	2250	0.12	1740	0.2	1080	0.4
5	4 x D	8500	16	3190	0.15	2470	0.25	1530	0.5
6	4 x D	11100	21	7230	0.18	5600	0.3	3480	0.6
8	4 x D	8300	28	6950	0.24	5380	0.4	3350	0.8
10	3 x D	7300	26	7640	0.3	5920	0.5	3680	1
10	4 x D	6600	34	6950	0.3	5380	0.5	3350	1
12	3 x D	6100	35	9740	0.36	7550	0.6	4690	1.2
12	4 x D	5500	43	8860	0.36	6860	0.6	4270	1.2
12	5 x D	4700	52	7550	0.36	5850	0.6	3640	1.2
16	3 x D	4500	46	8600	0.48	6660	0.8	4140	1.6
16	4 x D	4100	57	7810	0.48	6050	0.8	3760	1.6
16	5 x D	3500	69	6660	0.48	5160	0.8	3210	1.6
20	4 x D	3300	72	6770	0.6	5240	1	3260	2

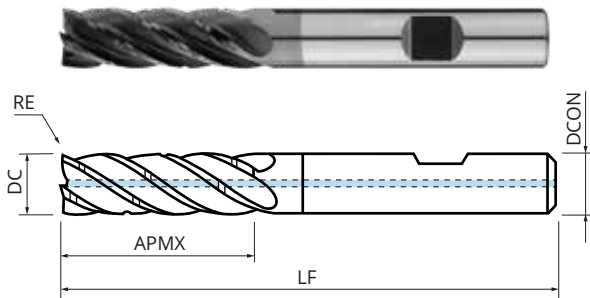

- Zur Anwendung in Stahl, rostfreiem Stahl, Guss und Superlegierungen *Pour l'utilisation dans l'acier, l'acier inoxydable, la fonte et les superalliages*
- Mit zentraler Innenkühlung für bessere Standzeiten und bessere Späneabfuhr speziell in Taschen *Avec refroidissement par le centre pour une meilleure durée de vie de l'outil et une meilleure évacuation des copeaux surtout pour le fraisage de poches*
- Mit Spanteiler für kurze Späne *Avec brise copeau pour copeaux courts*

ABMESSUNGEN *Dimensions*

Artikelnummer <i>Référence</i> (WGR. 7683)	DC	ULDR	APMX	LF	DCON	RE	ZEPF
	mm		mm	mm	mm	mm	
RCRL 4040R02- IKZ	4	4xD	16	60	6	0.2	4
RCRL 4050R02- IKZ	5	4xD	20	62	6	0.2	4
RCRL 5060R02- IKZ	6	4xD	24	70	6	0.2	5
RCRL 5080R02- IKZ	8	4xD	32	75	8	0.2	5
RCRL 5100R02- IKZ	10	3xD	30	80	10	0.2	5
RCRL 5100R02- IKZ	10	4xD	40	90	10	0.2	5
RCRL 6120R03- IKZ	12	3xD	36	93	12	0.3	6
RCRL 6120R03- IKZ	12	4xD	48	105	12	0.3	6
RCRL 6160R03- IKZ	16	3xD	48	105	16	0.3	6
RCRL 6160R03- IKZ	16	4xD	64	120	16	0.3	6
RCRL 6200R05- IKZ	20	4xD	80	140	20	0.5	6

SCHNITTDATEN *Données de coupe*

Material <i>Matière</i>		Baustahl <i>Acier de construction</i>							
		3% ae			5% ae			10% ae	
DC mm	ULDR	n min ⁻¹	ap mm	Vf mm/min	ae mm	Vf mm/min	ae mm	Vf mm/min	ae mm
4	4 x D	9500	13	2970	0.12	2300	0.2	1430	0.4
5	4 x D	10700	16	4440	0.15	3440	0.25	2140	0.5
6	4 x D	12700	21	9920	0.18	7690	0.3	4780	0.6
8	4 x D	9500	28	12410	0.24	9610	0.4	5980	0.8
10	3 x D	8400	26	9820	0.3	7610	0.5	4730	1
10	4 x D	7600	34	8930	0.3	6920	0.5	4300	1
12	3 x D	7000	35	12450	0.36	9640	0.6	6000	1.2
12	4 x D	6300	43	11310	0.36	8760	0.6	5450	1.2
16	3 x D	5200	46	10640	0.48	8240	0.8	5130	1.6
16	4 x D	4700	57	9680	0.48	7490	0.8	4660	1.6
20	4 x D	3800	72	8930	0.6	6920	1	4300	2

Material <i>Matière</i>		Werkzeugstahl <i>Acier à outil</i>							
		3% ae			5% ae			10% ae	
DC mm	ULDR	n min ⁻¹	ap mm	Vf mm/min	ae mm	Vf mm/min	ae mm	Vf mm/min	ae mm
4	4 x D	7300	13	1970	0.12	1530	0.2	950	0.4
5	4 x D	8100	16	3050	0.15	2360	0.25	1470	0.5
6	4 x D	9700	21	6340	0.18	4910	0.3	3050	0.6
8	4 x D	7300	28	6080	0.24	4710	0.4	2930	0.8
10	3 x D	6400	26	6710	0.3	5200	0.5	3230	1
10	4 x D	5800	34	6080	0.3	4710	0.5	2930	1
12	3 x D	5300	35	8560	0.36	6630	0.6	4120	1.2
12	4 x D	4800	43	7760	0.36	6010	0.6	3740	1.2
16	3 x D	4000	46	7550	0.48	5850	0.8	3640	1.6
16	4 x D	3600	57	6850	0.48	5300	0.8	3300	1.6
20	4 x D	2900	72	5930	0.6	4590	1	2860	2

SCHNITTDATEN *Données de coupe*

Material <i>Matière</i>		Rostfreier Stahl <i>Acier inoxydable</i>							
				3% ae		5% ae		10% ae	
DC mm	ULDR	n min ⁻¹	ap mm	Vf mm/min	ae mm	Vf mm/min	ae mm	Vf mm/min	ae mm
4	4 x D	6300	13	1170	0.12	910	0.2	560	0.4
5	4 x D	7100	16	1970	0.15	1530	0.25	950	0.5
6	4 x D	8400	21	4650	0.18	3600	0.3	2240	0.6
8	4 x D	6300	28	4590	0.24	3560	0.4	2210	0.8
10	3 x D	5600	26	5660	0.3	4380	0.5	2720	1
10	4 x D	5000	34	5140	0.3	3980	0.5	2480	1
12	3 x D	4600	35	6140	0.36	4760	0.6	2960	1.2
12	4 x D	4200	43	5580	0.36	4320	0.6	2690	1.2
16	3 x D	3500	46	6060	0.48	4700	0.8	2920	1.6
16	4 x D	3100	57	5510	0.48	4270	0.8	2650	1.6
20	4 x D	2500	72	5730	0.6	4440	1	2760	2

Material <i>Matière</i>		Guss <i>Fonte</i>							
				3% ae		5% ae		10% ae	
DC mm	ULDR	n min ⁻¹	ap mm	Vf mm/min	ae mm	Vf mm/min	ae mm	Vf mm/min	ae mm
4	4 x D	8300	13	2250	0.12	1740	0.2	1080	0.4
5	4 x D	8500	16	3190	0.15	2470	0.25	1530	0.5
6	4 x D	11100	21	7230	0.18	5600	0.3	3480	0.6
8	4 x D	8300	28	6950	0.24	5380	0.4	3350	0.8
10	3 x D	7300	26	7640	0.3	5920	0.5	3680	1
10	4 x D	6600	34	6950	0.3	5380	0.5	3350	1
12	3 x D	6100	35	9740	0.36	7550	0.6	4690	1.2
12	4 x D	5500	43	8860	0.36	6860	0.6	4270	1.2
16	3 x D	4500	46	8600	0.48	6660	0.8	4140	1.6
16	4 x D	4100	57	7810	0.48	6050	0.8	3760	1.6
20	4 x D	3300	72	6770	0.6	5240	1	3260	2

SCHNITTDATEN *Données de coupe*

Material <i>Matière</i>		Inconel 625 <i>Inconel 625</i>							
				3% ae		5% ae		10% ae	
DC mm	ULDR	n min ⁻¹	ap mm	Vf mm/min	ae mm	Vf mm/min	ae mm	Vf mm/min	ae mm
4	4 x D	2300	13	440	0.12	340	0.2	210	0.4
5	4 x D	2600	16	740	0.15	570	0.25	350	0.5
6	4 x D	3100	21	1830	0.18	1420	0.3	880	0.6
8	4 x D	2300	28	1720	0.24	1330	0.4	830	0.8
10	3 x D	1900	26	1650	0.3	1280	0.5	790	1
10	4 x D	1900	34	1650	0.3	1280	0.5	790	1
12	3 x D	1700	35	2420	0.36	1880	0.6	1160	1.2
12	4 x D	1500	43	2200	0.36	1700	0.6	1060	1.2
16	3 x D	1300	46	2730	0.48	2110	0.8	1310	1.6
16	4 x D	1100	57	2480	0.48	1920	0.8	1190	1.6
20	4 x D	900	72	2310	0.6	1790	1	1110	2

Material <i>Matière</i>		Titan <i>Titane</i>							
				3% ae		5% ae		10% ae	
DC mm	ULDR	n min ⁻¹	ap mm	Vf mm/min	ae mm	Vf mm/min	ae mm	Vf mm/min	ae mm
4	4 x D	3100	13	580	0.12	450	0.2	280	0.4
5	4 x D	3100	16	880	0.15	680	0.25	420	0.5
6	4 x D	3900	21	2290	0.18	1780	0.3	1100	0.6
8	4 x D	2900	28	2150	0.24	1660	0.4	1030	0.8
10	3 x D	2600	26	2280	0.3	1770	0.5	1100	1
10	4 x D	2300	34	2060	0.3	1600	0.5	990	1
12	3 x D	2200	35	2670	0.36	2060	0.6	1280	1.2
12	4 x D	1900	43	2410	0.36	1860	0.6	1160	1.2
16	3 x D	1600	46	2280	0.48	1770	0.8	1100	1.6
16	4 x D	1400	57	2060	0.48	1600	0.8	990	1.6
20	4 x D	1100	72	2060	0.6	1600	1	990	2

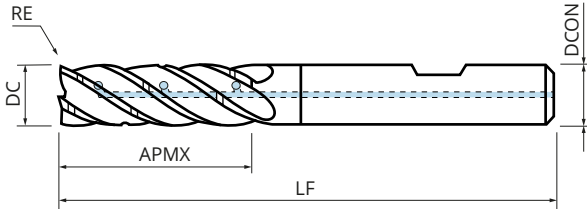

- Zur Anwendung in Stahl bis HRC 63, rostfreiem Stahl und Superlegierungen *Pour l'utilisation dans l'acier jusqu'à 63 HRC, l'acier inoxydable et les superalliages*
- Mit radialer Innenkühlung für bessere Standzeiten, bessere Wärme- und Späneabfuhr *Avec refroidissement interne radiale pour une meilleure durée de vie et une meilleure évacuation de la chaleur et des copeaux*
- Mit Spanteiler für kurze Späne *Avec brise copeau pour copeaux courts*

ABMESSUNGEN *Dimensions*

Artikelnummer <i>Référence</i>	DC	ULDR	APMX	LF	DCON	RE	ZEFP
(WGR. 7685)	mm		mm	mm	mm	mm	
RCRCM 5080R05-IKR	8	3xD	24	64	8	0.5	5
RCRCM 5100R05-IKR	10	3xD	30	73	10	0.5	5
RCRCM 5100R10-IKR	10	3xD	30	73	10	1	5
RCRCM 5120R05-IKR	12	3xD	36	84	12	0.5	5
RCRCM 5120R10-IKR	12	3xD	36	84	12	1	5
RCRCM 5160R10-IKR	16	3xD	48	110	16	1	5

SCHNITTDATEN *Données de coupe*

Material <i>Matière</i>	Unlegierter Stahl <i>Acier non allié</i>						Niedriglegierter Stahl <i>Acier faiblement allié</i>					
	Schichten <i>Finition</i>		Schruppen <i>Ébauche</i>				Schichten <i>Finition</i>		Schruppen <i>Ébauche</i>			
DC mm	n min ⁻¹	Vf mm/min	n min ⁻¹	Vf mm/min	n min ⁻¹	Vf mm/min	n min ⁻¹	Vf mm/min	n min ⁻¹	Vf mm/min	n min ⁻¹	Vf mm/min
8	7100	2480	8700	4780	9900	10890	5700	1710	7500	3750	8900	8450
10	5700	2560	7000	4900	7900	10660	4500	1800	6000	3600	7100	8520
12	4700	2820	5800	5510	6600	12210	3800	1900	5000	3500	5900	8550
16	3500	2970	4300	5590	4900	12740	2800	2240	3700	3510	4400	8360
	ap = 2 x D ae = 0.02 x D		ap = 2.5 x D ae = 0.1 x D		ap = 2.5 x D ae = 0.05 x D		ap = 2 x D ae = 0.02 x D		ap = 2.5 x D ae = 0.1 x D		ap = 2.5 x D ae = 0.05 x D	

Material <i>Matière</i>	Legierter Stahl <i>Acier allié</i>						Hochlegierter Stahl <i>Acier fortement allié</i>										
	1.2311 / 1.2312 / 1.2714 / 1.2738												1.2080 / 1.2379				
DC mm	Schichten <i>Finition</i>		Schruppen <i>Ébauche</i>				Schichten <i>Finition</i>		Schruppen <i>Ébauche</i>								
	n min ⁻¹	Vf mm/min	n min ⁻¹	Vf mm/min	n min ⁻¹	Vf mm/min	n min ⁻¹	Vf mm/min	n min ⁻¹	Vf mm/min	n min ⁻¹	Vf mm/min					
8	4400	1320	5800	2610	6900	6210	3800	950	5100	2040	5600	4480					
10	3500	1220	4600	2530	5500	6050	3100	1080	4100	2050	4500	4270					
12	2900	1300	3800	2470	4600	6210	2500	1000	3400	1870	3700	4250					
16	2200	1320	2900	2610	3400	6120	1900	1040	2500	1870	2800	4340					
	ap = 2 x D ae = 0.017 x D		ap = 2 x D ae = 0.075 x D		ap = 2.5 x D ae = 0.04 x D		ap = 1.5 x D ae = 0.015 x D		ap = 2 x D ae = 0.06 x D		ap = 2 x D ae = 0.035 x D						

Material <i>Matière</i>	Werkzeugstahl <i>Acier à outil</i>										
	1.2343 / 1.2344 / 1.2365 / 1.2367										
DC mm	Schichten <i>Finition</i>		Schruppen <i>Ébauche</i>								
	n min ⁻¹	Vf mm/min	n min ⁻¹	Vf mm/min	n min ⁻¹	Vf mm/min					
8	3500	870	4700	1410	5200	3380					
10	2800	840	3800	1330	4200	3360					
12	2300	800	3100	1390	3500	3320					
16	1700	760	2300	1380	2600	3380					
	ap = 1.5 x D ae = 0.012 x D		ap = 1.5 x D ae = 0.05 x D		ap = 1.5 x D ae = 0.025 x D						

SCHNITTDATEN *Données de coupe*

Material Matière	Martensitischer Stahl <i>Acier martensitique</i>						Austenitischer Stahl <i>Acier austenitique</i>					
	Schichten <i>Finition</i>		Schruppen <i>Ébauche</i>				Schichten <i>Finition</i>		Schruppen <i>Ébauche</i>			
DC mm	n min ⁻¹	Vf mm/min	n min ⁻¹	Vf mm/min	n min ⁻¹	Vf mm/min	n min ⁻¹	Vf mm/min	n min ⁻¹	Vf mm/min	n min ⁻¹	Vf mm/min
8	5500	1840	5900	3480	6900	5790	4700	1570	5000	2950	5900	4950
10	4400	1840	4700	3450	5500	5770	3700	1550	4000	2940	4700	4930
12	3700	1860	3900	3430	4600	5790	3100	1560	3300	2900	3900	4910
16	2700	1800	2900	3400	3400	5710	2300	1540	2500	2930	2900	4870
	ap = 2 x D ae = 0.02 x D		ap = 2 x D ae = 0.08 x D		ap = 2 x D ae = 0.04 x D		ap = 2 x D ae = 0.02 x D		ap = 2 x D ae = 0.08 x D		ap = 2 x D ae = 0.04 x D	

Material Matière	Duplex <i>Duplex</i>						Super Duplex <i>Super duplex</i>					
	Schichten <i>Finition</i>		Schruppen <i>Ébauche</i>				Schichten <i>Finition</i>		Schruppen <i>Ébauche</i>			
DC mm	n min ⁻¹	Vf mm/min	n min ⁻¹	Vf mm/min	n min ⁻¹	Vf mm/min	n min ⁻¹	Vf mm/min	n min ⁻¹	Vf mm/min	n min ⁻¹	Vf mm/min
8	3600	1060	3800	1740	4500	3190	2200	520	2300	850	2700	1550
10	2800	1030	3100	1780	3600	3200	1700	510	1900	880	2200	1580
12	2400	1060	2500	1720	3000	3190	1400	500	1500	840	1800	1550
16	1800	1330	1900	1740	2200	3120	1100	520	1100	810	1300	1490
	ap = 1.5 x D ae = 0.018 x D		ap = 1.5 x D ae = 0.06 x D		ap = 2 x D ae = 0.03 x D		ap = 1.5 x D ae = 0.018 x D		ap = 1.5 x D ae = 0.05 x D		ap = 1.5 x D ae = 0.025 x D	

Material Matière	Fe-Basis Superlegierung <i>Fe-base superalliage</i>						Ni - Co <i>Ni - Co</i>					
	Schichten <i>Finition</i>		Schruppen <i>Ébauche</i>				Schichten <i>Finition</i>		Schruppen <i>Ébauche</i>			
DC mm	n min ⁻¹	Vf mm/min	n min ⁻¹	Vf mm/min	n min ⁻¹	Vf mm/min	n min ⁻¹	Vf mm/min	n min ⁻¹	Vf mm/min	n min ⁻¹	Vf mm/min
8	3600	900	3800	1270	4500	2270	1900	470	2300	770	2900	1460
10	2800	880	3100	1300	3600	2260	1500	470	1900	790	2300	1440
12	2400	910	2500	1260	3000	2260	1300	490	1500	750	1900	1430
16	1800	900	1900	1270	2200	2220	900	490	1100	730	1400	1410
	ap = 2 x D ae = 0.012 x D		ap = 2 x D ae = 0.08 x D		ap = 2 x D ae = 0.04 x D		ap = 2 x D ae = 0.01 x D		ap = 2 x D ae = 0.08 x D		ap = 2 x D ae = 0.04 x D	

SCHNITTDATEN *Données de coupe*

Material <i>Matière</i>	Ni - Co <i>Ni - Co</i>						Titan <i>Titane</i>					
	1200 N/mm ²											
	Schichten <i>Finition</i>		Schruppen <i>Ébauche</i>				Schichten <i>Finition</i>		Schruppen <i>Ébauche</i>			
DC mm	n min ⁻¹	Vf mm/min	n min ⁻¹	Vf mm/min	n min ⁻¹	Vf mm/min	n min ⁻¹	Vf mm/min	n min ⁻¹	Vf mm/min	n min ⁻¹	Vf mm/min
8	1300	220	1500	360	1900	630	2800	500	3000	750	3700	1330
10	1100	230	1200	370	1500	630	2200	490	2400	750	3000	1350
12	900	220	1000	370	1300	650	1900	510	2000	760	2500	1350
16	600	200	700	340	900	600	1400	500	1500	750	1800	1290
	ap = 1.5 x D ae = 0.009 x D		ap = 1.5 x D ae = 0.06 x D		ap = 2 x D ae = 0.03 x D		ap = 2.5 x D ae = 0.02 x D		ap = 2 x D ae = 0.1 x D		ap = 2.5 x D ae = 0.05 x D	

Material <i>Matière</i>	Gehärteter Stahl <i>Acier trempé</i>						Gehärteter Stahl <i>Acier trempé</i>					
	HRC 44 - 49											
	Schichten <i>Finition</i>		Schruppen <i>Ébauche</i>				Schichten <i>Finition</i>		Schruppen <i>Ébauche</i>			
DC mm	n min ⁻¹	Vf mm/min	n min ⁻¹	Vf mm/min	n min ⁻¹	Vf mm/min	n min ⁻¹	Vf mm/min	n min ⁻¹	Vf mm/min	n min ⁻¹	Vf mm/min
8	4100	900	4700	1380	5100	3000	3600	750	4100	1140	4300	2400
10	3300	920	3800	1400	4100	3030	2800	740	3300	1150	3500	2450
12	2700	900	3100	1370	3400	3020	2400	750	2700	1130	2900	2430
16	2000	890	2300	1350	2500	2960	1800	750	2000	1120	2100	2350
	ap = 2 x D ae = 0.015 x D		ap = 2 x D ae = 0.035 x D		ap = 2 x D ae = 0.018 x D		ap = 2 x D ae = 0.012 x D		ap = 2 x D ae = 0.03 x D		ap = 2 x D ae = 0.015 x D	

Material <i>Matière</i>	Gehärteter Stahl <i>Acier trempé</i>					
	HRC 56 - 63					
	Schichten <i>Finition</i>		Schruppen <i>Ébauche</i>			
DC mm	n min ⁻¹	Vf mm/min	n min ⁻¹	Vf mm/min	n min ⁻¹	Vf mm/min
8	2500	450	2800	670	3000	1440
10	2000	450	2200	660	2400	1440
12	1600	430	1900	680	2000	1440
16	1200	430	1400	670	1500	1440
	ap = 2 x D ae = 0.01 x D		ap = 2 x D ae = 0.025 x D		ap = 2 x D ae = 0.012 x D	

GSXMT 4000

VHM-Schaftfräser
Fraise cylindrique en carbure

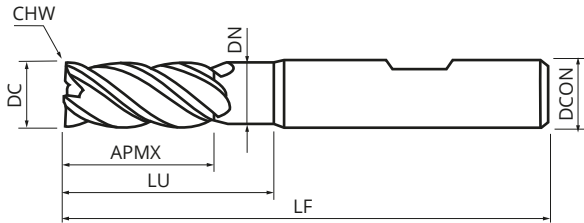

- Besonders gut geeignet zum Tauchfräsen in Stahl und rostfreiem Stahl *Pour le fraisage en plongée dans l'acier et l'acier inoxydable*
- Geeignet für bis zu 45° Ramping-Winkel, 3 – 5° maximaler Helix-Winkel *Pour le fraisage en rampe jusqu'à 45°, fraisage hélicoïdale max. 3 – 5°*
- Bohrbearbeitung möglich *Opération de perçage possible*

ABMESSUNGEN *Dimensions*

Artikelnummer <i>Référence</i>	DC	APMX	LU	LF	DCON	DN	CHW	ZEPF
(WGR. 7688)	mm	mm	mm	mm	mm	mm	mm	
GSXMT 4030-HB	3	8	15	57	6	2.8	0.15	4
GSXMT 4040-HB	4	11	18	57	6	3.8	0.15	4
GSXMT 4050-HB	5	13	18	57	6	4.8	0.15	4
GSXMT 4060-HB	6	13	20	57	6	5.8	0.2	4
GSXMT 4080-HB	8	19	26	63	8	7.6	0.2	4
GSXMT 4100-HB	10	22	30	72	10	9.5	0.3	4
GSXMT 4120-HB	12	26	36	83	12	11.5	0.35	4
GSXMT 4160-HB	16	32	42	92	16	15.5	0.4	4
GSXMT 4200-HB	20	38	52	104	20	19.5	0.5	4

SCHNITTDATEN *Données de coupe*

Bearbeitung <i>Usinage</i>			VOLLNUTFRÄSEN <i>Rainurage</i>								
Material <i>Matière</i>	Bemerkung <i>Note</i>	ap (xD) mm	ae (xD) mm	Vc m/min	4 mm/Z	6 mm/Z	8 mm/Z	10 mm/Z	12 mm/Z	16 mm/Z	20 mm/Z
Stahl <i>Acier</i>	< 850 N/mm ²	1	1	130 - 150	0.024	0.030	0.040	0.050	0.060	0.080	0.100
	< 1200 N/mm ²	1	1	90 - 110	0.018	0.022	0.028	0.034	0.039	0.049	0.059
	< 1400 N/mm ²	1	1	50 - 70	0.014	0.018	0.024	0.029	0.032	0.041	0.049
Rostfreier Stahl <i>Acier inoxydable</i>	< 750 N/mm ²	1	1	70 - 90	0.018	0.022	0.028	0.034	0.032	0.049	0.059
	< 950 N/mm ²	0.5	1	50 - 70	0.014	0.017	0.022	0.026	0.030	0.038	0.046
Guss <i>Fonte</i>	< 300 HB	1	1	90 - 130	0.018	0.022	0.028	0.034	0.039	0.049	0.059
Superlegierung <i>Superalliage</i>	Titan <i>Titane</i> < 1100 N/mm ²	0.5	1	30 - 50	0.014	0.017	0.022	0.026	0.030	0.038	0.046
	HRSA < 1300 N/mm ²	0.5	1	30 - 50	0.014	0.017	0.022	0.026	0.030	0.038	0.046

Bearbeitung <i>Usinage</i>			UMFANGSRÄSEN <i>Contournage</i>								
Material <i>Matière</i>	Bemerkung <i>Note</i>	ap (xD) mm	ae (xD) mm	Vc m/min	4 mm/Z	6 mm/Z	8 mm/Z	10 mm/Z	12 mm/Z	16 mm/Z	20 mm/Z
Stahl <i>Acier</i>	< 850 N/mm ²	1	0.3	150 - 180	0.024	0.030	0.040	0.050	0.060	0.080	0.100
	< 1200 N/mm ²	1	0.3	120 - 150	0.019	0.024	0.032	0.040	0.048	0.056	0.080
	< 1400 N/mm ²	1	0.3	60 - 80	0.018	0.023	0.030	0.036	0.041	0.047	0.063
Rostfreier Stahl <i>Acier inoxydable</i>	< 750 N/mm ²	1.5	0.5	90 - 110	0.021	0.026	0.034	0.041	0.047	0.052	0.071
	< 950 N/mm ²	1.2	0.3	60 - 80	0.018	0.023	0.030	0.036	0.041	0.047	0.063
Guss <i>Fonte</i>	< 300 HB	1	0.3	120 - 150	0.021	0.026	0.034	0.041	0.047	0.052	0.071
Superlegierung <i>Superalliage</i>	Titan <i>Titane</i> < 1100 N/mm ²	1	0.3	40 - 50	0.026	0.032	0.042	0.050	0.057	0.064	0.078
	HRSA < 1300 N/mm ²	1	0.3	40 - 50	0.026	0.032	0.042	0.050	0.057	0.064	0.078

Bearbeitung <i>Usinage</i>			RAMPING <i>Fraisage en rampe</i>								
Material <i>Matière</i>	Bemerkung <i>Note</i>	α °	ae (xD) mm	Vc m/min	4 mm/Z	6 mm/Z	8 mm/Z	10 mm/Z	12 mm/Z	16 mm/Z	20 mm/Z
Stahl <i>Acier</i>	< 850 N/mm ²	45	1	100 - 120	0.015	0.019	0.021	0.024	0.028	0.035	0.043
	< 1200 N/mm ²	15	1	55 - 75	0.014	0.017	0.023	0.023	0.026	0.032	0.039
	< 1400 N/mm ²	nicht empfohlen <i>non recommandé</i>									
Rostfreier Stahl <i>Acier inoxydable</i>	< 750 N/mm ²	10	1	60 - 80	0.014	0.018	0.023	0.028	0.032	0.040	0.048
	< 950 N/mm ²	5	1	45 - 65	0.014	0.017	0.022	0.026	0.030	0.038	0.046
Guss <i>Fonte</i>	< 300 HB	15	1	60 - 80	0.014	0.018	0.023	0.028	0.032	0.040	0.048
Superlegierung <i>Superalliage</i>	Titan <i>Titane</i> < 1100 N/mm ²	5	1	30 - 40	0.018	0.023	0.030	0.036	0.042	0.052	0.063
	HRSA < 1300 N/mm ²	5	1	30 - 40	0.018	0.023	0.030	0.036	0.042	0.052	0.063

Bearbeitung <i>Usinage</i>			HELIX-FRÄSEN <i>Fraisage hélicoïdal</i>								
Material <i>Matière</i>	Bemerkung <i>Note</i>	α °	ae (xD) mm	Vc m/min	4 mm/Z	6 mm/Z	8 mm/Z	10 mm/Z	12 mm/Z	16 mm/Z	20 mm/Z
Stahl <i>Acier</i>	< 850 N/mm ²	5	0.3	110 - 130	0.014	0.018	0.024	0.030	0.032	0.040	0.048
	< 1200 N/mm ²	4	0.3	70 - 90	0.013	0.016	0.021	0.026	0.029	0.037	0.045
	< 1400 N/mm ²	3	0.3	50 - 70	0.012	0.015	0.019	0.023	0.026	0.032	0.039
Rostfreier Stahl <i>Acier inoxydable</i>	< 750 N/mm ²	4	0.4	70 - 90	0.013	0.016	0.021	0.026	0.029	0.037	0.045
	< 950 N/mm ²	3	0.4	70 - 90	0.012	0.015	0.019	0.023	0.026	0.036	0.039
Guss <i>Fonte</i>	< 300 HB	4	0.4	70 - 90	0.013	0.016	0.021	0.026	0.029	0.037	0.045
Superlegierung <i>Superalliage</i>	Titan <i>Titane</i> < 1100 N/mm ²	3	0.4	30 - 50	0.011	0.014	0.019	0.021	0.024	0.030	0.037
	HRSA < 1300 N/mm ²	3	0.4	30 - 50	0.011	0.014	0.019	0.021	0.024	0.030	0.037

Bearbeitung <i>Usinage</i>			BOHREN <i>Perçage</i>								
Material <i>Matière</i>	Bemerkung <i>Note</i>	ap (xD) mm	ae (xD) mm	Vc m/min	4 mm/Z	6 mm/Z	8 mm/Z	10 mm/Z	12 mm/Z	16 mm/Z	20 mm/Z
Stahl <i>Acier</i>	< 850 N/mm ²	1	1	85 - 105	0.010	0.012	0.016	0.019	0.022	0.027	0.033
	< 1200 N/mm ²	1	1	55 - 75	0.009	0.011	0.014	0.017	0.019	0.024	0.030
	< 1400 N/mm ²	nicht empfohlen <i>non recommandé</i>									
Rostfreier Stahl <i>Acier inoxydable</i>	< 750 N/mm ²	1	1	55 - 75	0.009	0.011	0.014	0.017	0.019	0.024	0.030
	< 950 N/mm ²	nicht empfohlen <i>non recommandé</i>									
Guss <i>Fonte</i>	< 300 HB	1	1	55 - 75	0.009	0.011	0.014	0.017	0.019	0.024	0.030
Superlegierung <i>Superalliage</i>	Titan <i>Titane</i> < 1100 N/mm ²	0.5	1	20 - 40	0.010	0.013	0.017	0.021	0.024	0.030	0.036
	HRSA < 1300 N/mm ²	nicht empfohlen <i>non recommandé</i>									

Bearbeitung <i>Usinage</i>			TROCHOIDALFRÄSEN <i>Fraisage trochoïdale</i>								
Material <i>Matière</i>	Bemerkung <i>Note</i>	ap (xD) mm	ae (xD) mm	Vc m/min	4 mm/Z	6 mm/Z	8 mm/Z	10 mm/Z	12 mm/Z	16 mm/Z	20 mm/Z
Stahl <i>Acier</i>	< 850 N/mm ²	2	0.1	160 - 200	0.049	0.061	0.079	0.095	0.108	0.135	0.164
	< 1200 N/mm ²	2	0.1	110 - 130	0.044	0.055	0.071	0.085	0.097	0.122	0.148
	< 1400 N/mm ²	2	0.1	80 - 100	0.039	0.049	0.063	0.076	0.086	0.108	0.131
Rostfreier Stahl <i>Acier inoxydable</i>	< 750 N/mm ²	2	0.1	110 - 130	0.044	0.055	0.071	0.085	0.097	0.122	0.147
	< 950 N/mm ²	2	0.1	80 - 100	0.039	0.049	0.063	0.076	0.086	0.108	0.131
Guss <i>Fonte</i>	< 300 HB	2	0.1	120 - 150	0.044	0.055	0.071	0.085	0.097	0.122	0.148
Superlegierung <i>Superalliage</i>	Titan <i>Titane</i> < 1100 N/mm ²	2	0.05	50 - 70	0.054	0.067	0.087	0.104	0.119	0.149	0.181
	HRSA < 1300 N/mm ²	2	0.05	50 - 70	0.054	0.067	0.087	0.104	0.119	0.149	0.181

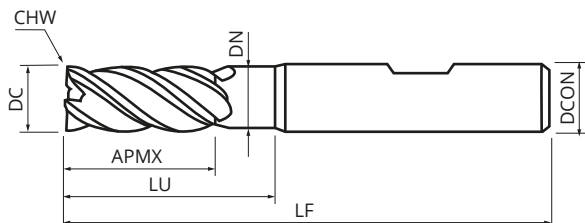

- Besonders gut geeignet in Stahl bis HRC 48 und Guss *Pour l'utilisation dans l'acier jusqu'à 48 HRC et la fonte*
- 5° maximaler Ramping-Winkel *Angle de rampe max. 5°*
- 5° maximaler Helix-Winkel *Fraisage hélicoïdale max. 5°*

ABMESSUNGEN – WELDON SCHAFT (HB) *Dimensions – queue avec méplat (HB)*

Artikelnummer <i>Référence</i> (WGR. 7688)	DC	APMX	LU	LF	DCON	DN	CHW	ZEPF
	mm	mm	mm	mm	mm	mm	mm	
GSXMF 4010-HB	1	2.5	5	57	6	0.8	0.07	4
GSXMF 4020-HB	2	5	10	57	6	1.8	0.1	4
GSXMF 4030-HB	3	8	15	57	6	2.8	0.1	4
GSXMF 4040-HB	4	11	17	57	6	3.8	0.15	4
GSXMF 4050-HB	5	13	19	57	6	4.8	0.15	4
GSXMF 4060-HB	6	13	21	57	6	5.8	0.2	4
GSXMF 4080-HB	8	19	27	63	8	7.6	0.2	4
GSXMF 4100-HB	10	22	32	72	10	9.5	0.3	4
GSXMF 4120-HB	12	26	38	83	12	11.5	0.35	4
GSXMF 4160-HB	16	32	44	92	16	15.5	0.4	4
GSXMF 4200-HB	20	38	54	104	20	19.5	0.5	4

ABMESSUNGEN – ZYLINDRISCHER SCHAFT (HA) *Dimensions – queue cylindrique (HA)*

Artikelnummer <i>Référence</i> (WGR. 7688)	DC	APMX	LU	LF	DCON	DN	CHW	ZEPF
	mm	mm	mm	mm	mm	mm	mm	
GSXMF 4010-HA	1	2.5	5	57	6	0.8	0.07	4
GSXMF 4020-HA	2	5	10	57	6	1.8	0.1	4
GSXMF 4030-HA	3	8	15	57	6	2.8	0.1	4
GSXMF 4040-HA	4	11	17	57	6	3.8	0.15	4
GSXMF 4050-HA	5	13	19	57	6	4.8	0.15	4
GSXMF 4060-HA	6	13	21	57	6	5.8	0.2	4
GSXMF 4080-HA	8	19	27	63	8	7.6	0.2	4
GSXMF 4100-HA	10	22	32	72	10	9.5	0.3	4
GSXMF 4120-HA	12	26	38	83	12	11.5	0.35	4
GSXMF 4160-HA	16	32	44	92	16	15.5	0.4	4
GSXMF 4200-HA	20	38	54	104	20	19.5	0.5	4

SCHNITTDATEN *Données de coupe*

Material <i>Matière</i>	Stahl / legierter Stahl <i>Acier / Acier allié</i>															
	< 850 N/mm ²								< 1300 N/mm ²							
	100% ae				15% ae				50% ae				15% ae			
DC mm	n min ⁻¹	Vf mm/min	ap mm	ae mm	n min ⁻¹	Vf mm/min	ap mm	ae mm	n min ⁻¹	Vf mm/min	ap mm	ae mm	n min ⁻¹	Vf mm/min	ap mm	ae mm
1	28600	280	1	1	36600	1020	2	0.15	22200	220	1	0.5	28600	800	2	0.15
2	15900	310	2	2	19800	1020	4	0.3	11900	230	2	1	15100	780	4	0.3
3	12700	600	3	3	15900	1970	6	0.45	8400	400	3	1.5	10600	1310	6	0.45
4	9500	760	4	4	11900	2380	8	0.6	6300	500	4	2	7900	1580	8	0.6
5	7600	760	5	5	9500	2430	10	0.75	5000	500	5	2.5	6300	1610	10	0.75
6	6300	750	6	6	7900	2460	12	0.9	4200	500	6	3	5300	1650	12	0.9
8	4700	750	8	8	5900	2450	16	1.2	3100	490	8	4	3900	1620	16	1.2
10	3800	760	10	10	4700	2420	20	1.5	2500	500	10	5	3100	1590	20	1.5
12	3100	740	12	12	3900	2410	24	1.8	2100	500	12	6	2600	1610	24	1.8
16	2300	730	16	16	2900	2370	30	2.4	1500	480	16	8	1900	1550	30	2.4
20	1900	760	20	20	2300	2300	36	3	1200	480	20	10	1500	1500	36	3

Material <i>Matière</i>	Grauguss <i>Fonte grise</i>															
	< 600 N/mm ²								> 600 N/mm ²							
	100% ae				15% ae				50% ae				15% ae			
DC mm	n min ⁻¹	Vf mm/min	ap mm	ae mm	n min ⁻¹	Vf mm/min	ap mm	ae mm	n min ⁻¹	Vf mm/min	ap mm	ae mm	n min ⁻¹	Vf mm/min	ap mm	ae mm
1	31800	310	1	1	39700	1110	2	0.15	22200	220	1	0.5	30200	840	2	0.15
2	17500	350	2	2	21400	1110	4	0.3	11100	220	2	1	15100	780	4	0.3
3	13700	650	3	3	16900	2090	6	0.45	7400	350	3	1.5	10000	1240	6	0.45
4	10300	820	4	4	12700	2540	8	0.6	5500	440	4	2	7500	1500	8	0.6
5	8200	820	5	5	10100	2580	10	0.75	4400	440	5	2.5	6000	1530	10	0.75
6	6800	810	6	6	8400	2620	12	0.9	3700	440	6	3	5000	1560	12	0.9
8	5100	810	8	8	6300	2620	16	1.2	2700	430	8	4	3700	1530	16	1.2
10	4100	820	10	10	5000	2580	20	1.5	2200	440	10	5	3000	1540	20	1.5
12	3400	810	12	12	4200	2600	24	1.8	1800	430	12	6	2500	1550	24	1.8
16	2500	800	16	16	3100	2540	30	2.4	1300	410	16	8	1800	1470	30	2.4
20	2000	800	20	20	2500	2500	36	3	1100	440	20	10	1500	1500	36	3

Material <i>Matière</i>	Gehärteter Stahl <i>Acier trempé</i>							
	HRC 44 - 48							
	30% ae				15% ae			
DC mm	n min ⁻¹	Vf mm/min	ap mm	ae mm	n min ⁻¹	Vf mm/min	ap mm	ae mm
1	15900	120	1	0.3	19000	210	2	0.15
2	7900	150	2	0.6	9500	260	4	0.3
3	5300	230	3	0.9	6300	390	6	0.45
4	3900	210	4	1.2	4700	370	8	0.6
5	3100	210	5	1.5	3800	370	10	0.75
6	2600	210	6	1.8	3100	370	12	0.9
8	1900	210	8	2.4	2300	370	16	1.2
10	1500	210	10	3	1900	370	20	1.5
12	1300	210	12	3.6	1500	370	24	1.8
16	900	200	16	4.8	1100	340	30	2.4
20	700	190	20	6	900	340	36	3

GSXMVA 4000

VHM-Schaftfräser VA
VA fraise cylindrique en carbure

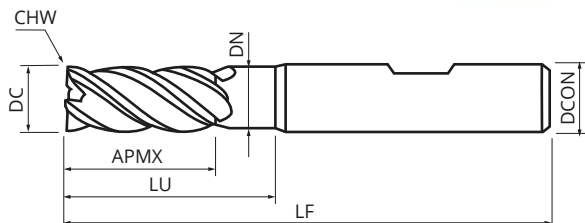

- Besonders gut geeignet in rostfreiem Stahl, Titan und Stahl *Pour l'utilisation dans l'acier, l'acier inoxydable et le titane*
- 5° maximaler Ramping-Winkel *Angle de rampe max 5°*
- 5° maximaler Helix-Winkel *Angle helix max 5°*

ABMESSUNGEN *Dimensions*

Artikelnummer <i>Référence</i>	DC	APMX	LU	LF	DCON	DN	CHW	ZEPF
(WGR. 7688)	mm	mm	mm	mm	mm	mm	mm	
GSXMVA 4030	3	8	15	57	6	2.8	0.1	4
GSXMVA 4040	4	11	17	57	6	3.8	0.15	4
GSXMVA 4050	5	13	19	57	6	4.8	0.15	4
GSXMVA 4060	6	13	21	57	6	5.8	0.2	4
GSXMVA 4080	8	19	27	63	8	7.6	0.2	4
GSXMVA 4100	10	22	32	72	10	9.5	0.3	4
GSXMVA 4120	12	26	38	83	12	11.5	0.35	4
GSXMVA 4160	16	32	44	92	16	15.5	0.4	4
GSXMVA 4200	20	38	54	104	20	19.5	0.5	4

SCHNITTDATEN *Données de coupe*

Material <i>Matière</i>	Stahl / legierter Stahl <i>Acier / Acier allié</i>															
	< 850 N/mm								< 1300 N/mm							
DC	100% ae				15% ae				50% ae				15% ae			
	n	Vf	ap	ae	n	Vf	ap	ae	n	Vf	ap	ae	n	Vf	ap	ae
	min ⁻¹	mm/min	mm	mm	min ⁻¹	mm/min	mm	mm	min ⁻¹	mm/min	mm	mm	min ⁻¹	mm/min	mm	mm
3	12700	760	3	3	15900	2410	6	0.45	6300	370	3	1.5	9500	1440	6	0.45
4	9500	760	4	4	11900	2380	8	0.6	4700	370	4	2	7100	1420	8	0.6
5	7600	760	5	5	9500	2470	10	0.75	3800	380	5	2.5	5700	1480	10	0.75
6	6300	750	6	6	7900	2460	12	0.9	3100	370	6	3	4700	1460	12	0.9
8	4700	750	8	8	5900	2450	16	1.2	2300	360	8	4	3500	1450	16	1.2
10	3800	760	10	10	4700	2420	20	1.5	1900	380	10	5	2800	1440	20	1.5
12	3100	740	12	12	3900	2410	24	1.8	1500	360	12	6	2300	1420	24	1.8
16	2300	690	16	16	2900	2370	30	2.4	1100	330	16	8	1700	1390	30	2.4
20	1900	680	20	20	2300	2300	36	3	900	320	20	10	1400	1400	36	3

Material <i>Matière</i>	Rostfrei Austenitisch <i>Acier austénitique</i>															
	< 600 N/mm								600 – 800 N/mm							
DC	100% ae				15% ae				100% ae				15% ae			
	n	Vf	ap	ae	n	Vf	ap	ae	n	Vf	ap	ae	n	Vf	ap	ae
	min ⁻¹	mm/min	mm	mm	min ⁻¹	mm/min	mm	mm	min ⁻¹	mm/min	mm	mm	min ⁻¹	mm/min	mm	mm
3	10000	600	3	3	12700	1930	6	0.45	7900	470	3	3	10600	1610	6	0.45
4	7500	600	4	4	9500	1900	8	0.6	5900	470	4	4	7900	1580	8	0.6
5	6000	600	5	5	7600	1970	10	0.75	4700	470	5	5	6300	1630	10	0.75
6	5000	600	6	6	6300	1960	12	0.9	3900	460	6	6	5300	1650	12	0.9
8	3700	590	8	8	4700	1950	16	1.2	2900	460	8	8	3900	1620	16	1.2
10	3000	600	10	10	3800	1960	20	1.5	2300	460	10	10	3100	1590	20	1.5
12	2500	600	12	12	3100	1920	24	1.8	1900	450	12	12	2600	1610	24	1.8
16	1800	540	16	16	2300	1880	30	2.4	1400	420	16	16	1900	1550	30	2.4
20	1500	540	20	20	1900	1900	36	3	1100	390	20	20	1500	1500	36	3

Material <i>Matière</i>	Duplex <i>Duplex</i>								Titan <i>Titane</i>							
	< 800 N/mm								900 - 1600 N/mm							
DC	50% ae				15% ae				30% ae				10% ae			
	n	Vf	ap	ae	n	Vf	ap	ae	n	Vf	ap	ae	n	Vf	ap	ae
	min ⁻¹	mm/min	mm	mm	min ⁻¹	mm/min	mm	mm	min ⁻¹	mm/min	mm	mm	min ⁻¹	mm/min	mm	mm
3	6300	300	3	1.5	8400	700	6	0.45	5300	210	3	0.9	7400	500	6	0.3
4	4700	300	4	2	6300	730	8	0.6	3900	210	4	1.2	5500	520	8	0.4
5	3800	300	5	2.5	5000	740	10	0.75	3100	210	5	1.5	4400	520	10	0.5
6	3100	290	6	3	4200	720	12	0.9	2600	210	6	1.8	3700	510	12	0.6
8	2300	290	8	4	3100	710	16	1.2	1900	210	8	2.4	2700	520	16	0.8
10	1900	300	10	5	2500	740	20	1.5	1500	210	10	3	2200	520	20	1
12	1500	280	12	6	2100	710	24	1.8	1300	210	12	3.6	1800	540	24	1.2
16	1100	280	16	8	1500	690	30	2.4	900	200	16	4.8	1300	490	30	1.6
20	900	280	20	10	1200	690	36	3	700	190	20	6	1100	520	36	2

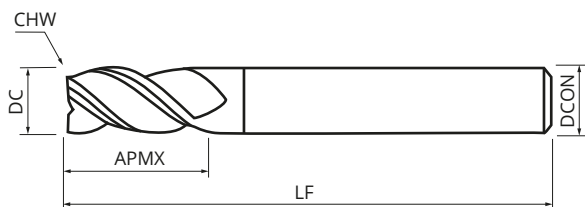

- Universell einsetzbares Fräs Werkzeug, besonders geeignet für instabile Bearbeitungen
Pour l'utilisation universelle, spécialement pour les applications instables
- Spezielle Geometrie zur Herstellung von Passfedernuten *Géométrie spéciale pour l'usage de rainures*
- Minustoleranz *Tolérance négative*

ABMESSUNGEN *Dimensions*

Artikelnummer <i>Référence</i>	DC	APMX	LF	DCON	CHW	TOL	ZEPF
(WGR. 7688)	mm	mm	mm	mm	mm	mm	
GSXMVA 3010	1	2	38	4	-	-0.02/-0.035	3
GSXMVA 3011	1.1	2.2	38	4	-	-0.02/-0.035	3
GSXMVA 3012	1.2	2.4	38	4	-	-0.02/-0.035	3
GSXMVA 3013	1.3	2.6	38	4	-	-0.02/-0.035	3
GSXMVA 3014	1.4	2.8	38	4	-	-0.02/-0.035	3
GSXMVA 3015	1.5	3	38	4	-	-0.02/-0.035	3
GSXMVA 3016	1.6	3.2	38	4	-	-0.02/-0.035	3
GSXMVA 3017	1.7	3.4	38	4	-	-0.02/-0.035	3
GSXMVA 3018	1.8	3.6	38	4	-	-0.02/-0.035	3
GSXMVA 3019	1.9	3.8	38	4	-	-0.02/-0.035	3
GSXMVA 3020	2	4	38	6	-	-0.02/-0.035	3
GSXMVA 3021	2.1	4.2	38	6	-	-0.02/-0.035	3
GSXMVA 3022	2.2	4.4	38	6	-	-0.02/-0.035	3
GSXMVA 3023	2.3	4.6	38	6	-	-0.02/-0.035	3
GSXMVA 3024	2.4	4.8	38	6	-	-0.02/-0.035	3
GSXMVA 3025	2.5	5	38	6	0.1	-0.02/-0.035	3
GSXMVA 3026	2.6	5.2	38	6	0.1	-0.02/-0.035	3
GSXMVA 3027	2.7	5.4	38	6	0.1	-0.02/-0.035	3
GSXMVA 3028	2.8	5.6	50	6	0.1	-0.02/-0.035	3
GSXMVA 3029	2.9	5.8	50	6	0.1	-0.02/-0.035	3
GSXMVA 3030	3	6	50	6	0.1	-0.02/-0.035	3
GSXMVA 3031	3.1	7	50	6	0.1	-0.025/-0.04	3
GSXMVA 3032	3.2	7	50	6	0.1	-0.025/-0.04	3
GSXMVA 3033	3.3	7	50	6	0.1	-0.025/-0.04	3
GSXMVA 3034	3.4	7	50	6	0.1	-0.025/-0.04	3
GSXMVA 3035	3.5	8	50	6	0.1	-0.025/-0.04	3
GSXMVA 3038	3.8	8	54	6	0.1	-0.025/-0.04	3
GSXMVA 3039	3.9	8	54	6	0.1	-0.025/-0.04	3

ABMESSUNGEN *Dimensions*

Artikelnummer <i>Référence</i>	DC	APMX	LF	DCON	CHW	TOL	ZEFP
(WGR. 7688)	mm	mm	mm	mm	mm	mm	
GSXMVA 3040	4	8	54	6	0.1	-0.025/-0.04	3
GSXMVA 3045	4.5	10	54	6	0.1	-0.025/-0.04	3
GSXMVA 3048	4.8	10	54	6	0.1	-0.025/-0.04	3
GSXMVA 3050	5	10	54	6	0.1	-0.025/-0.04	3
GSXMVA 30575	5.75	13	54	6	0.1	-0.025/-0.04	3
GSXMVA 3060	6	13	54	6	0.15	-0.025/-0.04	3
GSXMVA 3070	7	16	58	8	0.15	-0.03/-0.05	3
GSXMVA 30775	7.75	19	58	8	0.15	-0.03/-0.05	3
GSXMVA 3080	8	19	58	8	0.15	-0.03/-0.05	3
GSXMVA 3090	9	19	66	10	0.15	-0.03/-0.05	3
GSXMVA 3097	9.7	22	66	10	0.15	-0.03/-0.05	3
GSXMVA 3100	10	22	66	10	0.2	-0.03/-0.05	3
GSXMVA 3117	11.7	26	73	12	0.2	-0.035/-0.055	3
GSXMVA 3120	12	26	73	12	0.2	-0.035/-0.055	3
GSXMVA 3137	13.7	26	75	14	0.2	-0.035/-0.055	3
GSXMVA 3140	14	26	75	14	0.2	-0.035/-0.055	3
GSXMVA 3157	15.7	30	82	16	0.2	-0.035/-0.055	3
GSXMVA 3160	16	30	82	16	0.2	-0.035/-0.055	3

SCHNITTDATEN *Données de coupe*

Material <i>Matière</i>	Stahl / legierter Stahl <i>Acier / Acier allié</i>										
	< 850 N/mm										
	Bohren <i>Perçage</i>			100% ae				Schlichten <i>Finition</i>			
DC mm	n min ⁻¹	Vf mm/min	ap Step mm	n min ⁻¹	Vf mm/min	ap mm	ae mm	n min ⁻¹	Vf mm/min	ap mm	ae mm
1.0	31850	287	1	19110	287	1	1	22930	344	1	0.1
bis 1.5	21240	255	1.5	18050	407	1.5	1.5	21660	488	1.5	0.1
bis 2.0	15930	287	2	17520	526	2	2	21020	631	2	0.1
bis 2.5	12740	268	2.5	15290	574	2.5	2.5	20390	765	2.5	0.1
bis 3.0	12740	344	3	12740	574	3	3	16990	765	3	0.2
bis 4.0	9560	430	4	9560	574	4	4	12740	765	4	0.2
bis 5.0	8920	401	5	7650	574	5	5	10200	765	5	0.2
bis 6.0	7440	401	6	6370	574	6	6	8500	765	6	0.2
bis 7.0	6370	344	7	5460	574	7	7	7280	765	7	0.2
bis 8.0	5580	334	8	4780	574	8	8	6370	765	8	0.2
bis 9.0	4960	297	8	4250	574	9	9	5670	766	9	0.2
bis 10.0	4460	334	8	3830	575	10	10	5100	765	10	0.2
bis 12.0	3720	334	8	3190	575	12	12	4250	765	12	0.2
bis 14.0	3190	382	8	2730	574	14	14	3640	765	14	0.2
bis 16.0	2790	334	4	2390	574	16	16	3190	766	16	0.2

SCHNITTDATEN *Données de coupe*

Material <i>Matière</i>	Stahl / legierter Stahl <i>Acier / Acier allié</i>										
	< 1300 N/mm										
	Bohren <i>Perçage</i>			100% ae				Schlichten <i>Finition</i>			
DC mm	n min ⁻¹	Vf mm/min	ap Step mm	n min ⁻¹	Vf mm/min	ap mm	ae mm	n min ⁻¹	Vf mm/min	ap mm	ae mm
1.0	25480	229	1	17520	169	1	1	22930	207	1	0.1
bis 1.5	16990	204	1.5	16990	240	1.5	1.5	21660	293	1.5	0.1
bis 2.0	12740	229	2	12740	241	2	2	21020	373	2	0.1
bis 2.5	10200	214	2.5	10200	242	2.5	2.5	20390	453	2.5	0.1
bis 3.0	10620	287	3	8500	240	3	3	16990	454	3	0.2
bis 4.0	7970	358	4	6370	239	4	4	12740	451	4	0.2
bis 5.0	7650	344	5	5100	241	5	5	10200	453	5	0.2
bis 6.0	6370	344	6	4250	240	6	6	8500	495	6	0.2
bis 7.0	5460	295	7	3640	240	7	7	7280	494	7	0.2
bis 8.0	4780	287	8	3190	240	8	8	6370	495	8	0.2
bis 9.0	4250	255	8	2840	241	9	9	5670	495	9	0.2
bis 10.0	3830	287	8	2550	240	10	10	5100	495	10	0.2
bis 12.0	3190	287	8	2130	240	12	12	4250	495	12	0.2
bis 14.0	2730	328	8	1820	240	14	14	3640	494	14	0.2
bis 16.0	2390	287	4	1600	240	16	16	3190	495	16	0.2

Material <i>Matière</i>	Rostfreier Stahl <i>Acier inoxydable</i>										
	ferritisch und martensitisch <i>Ferritique et martensitique</i>										
	Bohren <i>Perçage</i>			100% ae				Schlichten <i>Finition</i>			
DC mm	n min ⁻¹	Vf mm/min	ap Step mm	n min ⁻¹	Vf mm/min	ap mm	ae mm	n min ⁻¹	Vf mm/min	ap mm	ae mm
1.0	22300	201	0.5	19110	230	1	1	22930	303	1	0.1
bis 1.5	14870	178	0.75	19110	344	1.5	1.5	21660	429	1.5	0.1
bis 2.0	11150	201	1	18320	440	2	2	21020	549	2	0.1
bis 2.5	8920	187	1.25	15290	459	2.5	2.5	20390	667	2.5	0.1
bis 3.0	9560	258	1.5	12740	459	3	3	16990	668	3	0.2
bis 4.0	7170	322	2	9560	459	4	4	12740	666	4	0.2
bis 5.0	6060	272	2.5	7650	459	5	5	10200	668	5	0.2
bis 6.0	5050	272	3	6370	522	6	6	8500	765	6	0.2
bis 7.0	4330	233	3.5	5460	523	7	7	7280	765	7	0.2
bis 8.0	3790	227	4	4780	522	8	8	6370	765	8	0.2
bis 9.0	3370	202	4.5	4250	523	9	9	5670	766	9	0.2
bis 10.0	3030	227	5	3830	523	10	10	5100	765	10	0.2
bis 12.0	2530	227	4	3190	523	12	12	4250	765	12	0.2
bis 14.0	2170	259	4	2730	522	14	14	3640	765	14	0.2
bis 16.0	1900	227	4	2390	522	16	16	3190	766	16	0.2

SCHNITTDATEN *Données de coupe*

Material <i>Matière</i>	Rostfreier Stahl <i>Acier inoxydable</i>										
	austenitisch <i>Austénitique</i>										
	Bohren <i>Perçage</i>			100% ae				Schlichten <i>Finition</i>			
DC mm	n min ⁻¹	Vf mm/min	ap Step mm	n min ⁻¹	Vf mm/min	ap mm	ae mm	n min ⁻¹	Vf mm/min	ap mm	ae mm
1.0	19110	172	0.3	17520	163	0.3	1	22930	221	0.3	0.1
bis 1.5	12740	153	0.45	16990	235	0.5	1.5	21660	306	0.5	0.1
bis 2.0	9560	172	0.6	12740	234	0.7	2	19110	362	0.7	0.1
bis 2.5	7650	161	0.75	10200	233	0.8	2.5	15290	363	0.8	0.1
bis 3.0	8500	229	0.9	8500	233	1	3	12740	360	1	0.2
bis 4.0	6370	287	1.2	6370	234	1.3	4	9560	359	1.3	0.2
bis 5.0	4780	215	1.5	5100	233	1.7	5	7650	361	1.7	0.2
bis 6.0	3990	215	1.8	4250	248	2	6	6370	383	6	0.2
bis 7.0	3420	184	2.1	3640	247	2.3	7	5460	384	7	0.2
bis 8.0	2990	179	2.4	3190	248	2.6	8	4780	383	8	0.2
bis 9.0	2660	159	2.7	2840	248	3	9	4250	383	9	0.2
bis 10.0	2390	179	3	2550	248	3.3	10	3830	384	10	0.2
bis 12.0	2000	179	3.6	2130	248	4	12	3190	383	12	0.2
bis 14.0	1710	205	4	1820	247	4.6	14	2730	383	14	0.2
bis 16.0	1500	179	4	1600	249	5.3	16	2390	383	16	0.2

Material <i>Matière</i>	Superlegierung <i>Superalloy</i>										
	Bohren <i>Perçage</i>			100% ae				Schlichten <i>Finition</i>			
DC mm	n min ⁻¹	Vf mm/min	ap Step mm	n min ⁻¹	Vf mm/min	ap mm	ae mm	n min ⁻¹	Vf mm/min	ap mm	ae mm
1.0	11150	100	0.33	19110	178	0.3	1	22300	208	0.3	0.1
bis 1.5	7440	89	0.49	12740	176	0.5	1.5	14870	206	0.5	0.1
bis 2.0	5580	100	0.66	9560	175	0.7	2	11150	205	0.7	0.1
bis 2.5	4460	94	0.82	7650	175	0.8	2.5	8920	204	0.8	0.1
bis 3.0	4780	129	0.99	6370	174	1	3	7440	204	1	0.2
bis 4.0	3590	161	1.32	4780	175	1.3	4	5580	205	1.3	0.2
bis 5.0	3190	143	1.65	3830	175	1.7	5	4460	204	1.7	0.2
bis 6.0	2660	143	1.98	3190	192	2	6	3720	224	2	0.2
bis 7.0	2280	123	2.31	2730	192	2.3	7	3190	224	2.3	0.2
bis 8.0	2000	119	2.64	2390	192	2.6	8	2790	224	8	0.2
bis 9.0	1770	106	2.97	2130	192	3	9	2480	224	9	0.2
bis 10.0	1600	119	3.3	1920	193	3.3	10	2230	224	10	0.2
bis 12.0	1330	119	4	1600	192	4	12	1860	224	12	0.2
bis 14.0	1140	136	4	1370	192	4.6	14	1600	225	14	0.2
bis 16.0	1000	119	3	1200	193	5.3	16	1400	225	16	0.2

GSXLVA 4000

VHM-SchaftFräser mit kleinen Fasen
Fraise cylindrique avec protection d'arêtes en carbure

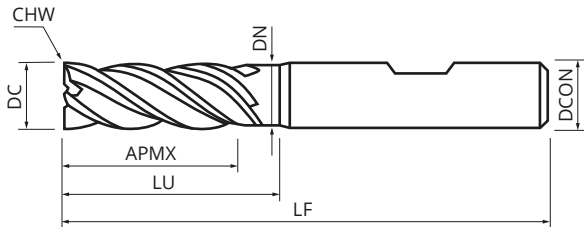

- Zur Anwendung in rostfreiem Stahl, Superlegierungen und Stahl bis HRC 45 *Pour l'utilisation dans l'acier inoxydable, les superalliages et l'acier jusqu'à 45 HRC*
- Kleinere Schutzfasen *Petit chanfrein de protection*
- Längere Schneide und Halsfreistellung *Coupe et détalonnage plus long*

ABMESSUNGEN *Dimensions*

Artikelnummer <i>Référence</i> (WGR. 7688)	DC	APMX	LU	LF	DCON	DN	CHW	ZEFP
	mm	mm	mm	mm	mm	mm	mm	
GSXLVA 4030	3	8	18	63	6	2.7	0.1	4
GSXLVA 4040	4	11	21	63	6	3.7	0.1	4
GSXLVA 4050	5	13	21	63	6	4.7	0.1	4
GSXLVA 4060	6	15	21	63	6	5.5	0.1	4
GSXLVA 4080	8	21	26	63	8	7.5	0.1	4
GSXLVA 4100	10	26	31	72	10	9.5	0.1	4
GSXLVA 4120	12	30	37	83	12	11.5	0.1	4
GSXLVA 4160	16	40	50	100	16	15.5	0.2	4
GSXLVA 4200	20	40	54	105	20	19.5	0.2	4

SCHNITTDATEN *Données de coupe*

Material <i>Matière</i>	Stahl / legierter Stahl <i>Acier / Acier allié</i>															
	500 - 900 N/mm ²								900 - 1300 N/mm ²							
	100% ae				50% ae				100% ae				50% ae			
DC mm	n min ⁻¹	Vf mm/min	ap mm	ae mm	n min ⁻¹	Vf mm/min	ap mm	ae mm	n min ⁻¹	Vf mm/min	ap mm	ae mm	n min ⁻¹	Vf mm/min	ap mm	ae mm
3	16100	323	3	3	16100	323	4.5	1.5	11350	227	3	3	11350	227	4.5	1.5
4	12100	387	4	4	12100	387	6	2	8520	272	4	4	8520	272	6	2
5	9680	426	5	5	9680	426	7.5	2.5	6820	300	5	5	6820	300	7.5	2.5
6	8070	516	6	6	8070	516	9	3	5680	363	6	6	5680	363	9	3
8	6050	653	8	8	6050	653	12	4	4260	460	8	8	4260	460	12	4
10	5350	813	10	10	5350	813	15	5	3730	566	10	10	3730	566	15	5
12	4450	838	12	12	4450	838	18	6	3100	583	12	12	3100	583	18	6
16	3350	709	16	16	3350	709	24	8	2330	493	16	16	2330	493	24	8
20	2680	695	20	20	2680	695	30	10	1870	484	20	20	1870	484	30	10

Material <i>Matière</i>	Rostfreier Stahl <i>Acier inoxydable</i>															
	ferritisch und martensitisch <i>Ferritique et martensitique</i>								austenitisch <i>Austénitique</i>							
	100% ae				50% ae				100% ae				50% ae			
DC mm	rpm min ⁻¹	Vf mm/min	ap mm	ae mm	rpm min ⁻¹	Vf mm/min	ap mm	ae mm	n min ⁻¹	Vf mm/min	ap mm	ae mm	n min ⁻¹	Vf mm/min	ap mm	ae mm
3	15700	251	3	3	15700	251	4.5	1.5	10100	202	3	3	10100	202	4.5	1.5
4	11800	283	4	4	11800	283	6	2	7560	242	4	4	7560	242	6	2
5	9400	339	5	5	9400	339	7.5	2.5	6050	314	5	5	6050	314	7.5	2.5
6	7850	408	6	6	7850	408	9	3	5040	363	6	6	5040	363	9	3
8	5890	518	8	8	5890	518	12	4	3780	423	8	8	3780	423	12	4
10	4710	641	10	10	4710	641	15	5	3024	581	10	10	3024	581	15	5
12	3930	612	12	12	3930	612	18	6	2520	554	12	12	2520	554	18	6
16	2950	530	16	16	2950	530	24	8	1890	469	16	16	1890	469	24	8
20	2350	518	20	20	2350	518	30	10	1520	460	20	20	1520	460	30	10

Material <i>Matière</i>	Superlegierung <i>Superalliage</i>															
	Titan <i>Titane</i>								Inconel <i>Inconel</i>							
	100% ae				40% ae				100% ae				25% ae			
DC mm	n min ⁻¹	Vf mm/min	ap mm	ae mm	n min ⁻¹	Vf mm/min	ap mm	ae mm	n min ⁻¹	Vf mm/min	ap mm	ae mm	n min ⁻¹	Vf mm/min	ap mm	ae mm
3	6150	98	1.5	3	6150	98	3	1.2	2800	55	1.5	3	2800	55	3	0.75
4	4620	129	2	4	4620	129	4	1.6	2070	58	2	4	2070	58	4	1
5	3690	162	2.5	5	3690	162	5	2	1650	53	2.5	5	1650	53	5	1.25
6	3080	198	3	6	3080	198	6	2.4	1380	66	3	6	1380	66	6	1.5
8	2310	231	4	8	2310	231	8	3.2	1040	79	4	8	1040	79	8	2
10	1850	310	5	10	1850	310	10	4	830	109	5	10	830	109	10	2.5
12	1540	308	6	12	1540	308	12	4.8	690	105	6	12	690	105	12	3
16	1150	254	8	16	1150	254	16	6.4	520	89	8	16	520	89	16	4
20	920	251	10	20	920	251	20	8	415	89	10	20	415	89	20	5

GCMT 5000

VHM-Schaftfräser – lang
Fraise cylindrique en carbure – longue

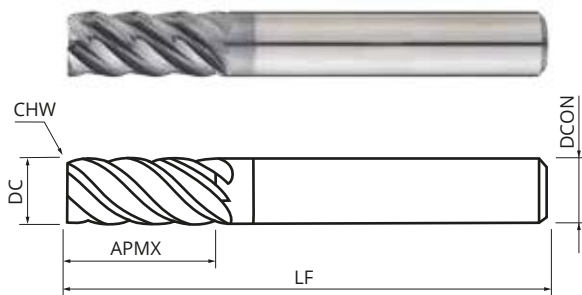

- Zur Anwendung in rostfreiem Stahl, Superlegierungen und Stahl bis HRC 45 *Pour l'utilisation dans l'acier inoxydable, les superalliages et l'acier jusqu'à 45 HRC*
- Verbessertes Schneidendesign für eine optimale Spanabfuhr und Stabilität beim Bearbeiten von schwer zerspanbaren Materialien *Design de coupe amélioré pour une évacuation optimale des copeaux et une meilleure stabilité lors de l'usinage de matériaux difficiles à couper*

ABMESSUNGEN *Dimensions*

Artikelnummer <i>Référence</i>	DC	APMX	LF	DCON	CHW	ZEFP
(WGR. 7676)	mm	mm	mm	mm	mm	
GCMT 5100	10	22	72	10	0.3	5
GCMT 5120	12	26	83	12	0.35	5
GCMT 5160	16	36	92	16	0.4	5

SCHNITTDATEN *Données de coupe*

Material <i>Matière</i>	Stahl / legierter Stahl <i>Acier / Acier allié</i>				Rostfreier Stahl <i>Acier inoxydable</i>			
	< 1300 N/mm ²				ferritisch und martensitisch <i>Ferritique et martensitique</i>			
	30% ae				30% ae			
DC mm	n min ⁻¹	Vf mm/min	ap mm	ae mm	n min ⁻¹	Vf mm/min	ap mm	ae mm
10	3215	804	15	3	2610	496	15	3
12	2679	844	18	3.6	2175	685	18	3.6
16	2009	764	24	4.8	1631	563	24	4.8

Material <i>Matière</i>	Rostfreier Stahl <i>Acier inoxydable</i>				Superlegierung <i>Superalliage</i>			
	austenitisch <i>Austénitique</i>				Titan <i>Titane</i>			
	30% ae				10% ae			
DC mm	n min ⁻¹	Vf mm/min	ap mm	ae mm	n min ⁻¹	Vf mm/min	ap mm	ae mm
10	3724	559	15	3	2196	373	15	1
12	3104	714	18	3.6	1830	522	18	1.2
16	2328	628	24	4.8	1373	426	24	1.6

Material <i>Matière</i>	Superlegierung <i>Superalliage</i>			
	Inconel			
	10% ae			
DC mm	n min ⁻¹	Vf mm/min	ap mm	ae mm
10	987	133	15	1
12	822	181	18	1.2
16	617	148	24	1.6

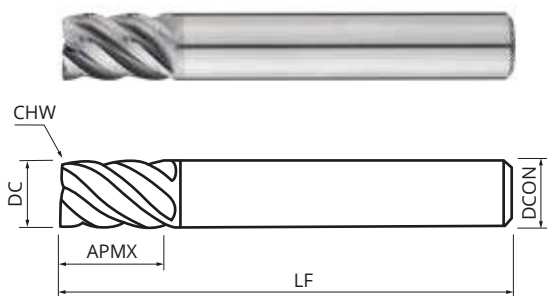

- Zur Anwendung in rostfreiem Stahl, Superlegierungen und Stahl bis HRC 45 *Pour l'utilisation dans l'acier inoxydable, les superalliages et l'acier jusqu'à 45 HRC*
- Spezielles Schneidendesign für HSC Bearbeitung *Design de coupe spécial pour l'usinage HSC*

ABMESSUNGEN *Dimensions*

Artikelnummer <i>Référence</i>	DC	APMX	LF	DCON	CHW	ZEFP
(WGR. 7676)	mm	mm	mm	mm	mm	
GCST 5060	6	13	57	6	0.2	5
GCST 5080	8	19	63	8	0.2	5
GCST 5100	10	14	66	10	0.3	5
GCST 5120	12	16	73	12	0.35	5

SCHNITTDATEN *Données de coupe*

Material <i>Matière</i>	Stahl / legierter Stahl <i>Acier / Acier allié</i>				Rostfreier Stahl <i>Acier inoxydable</i>			
	< 1300 N/mm ²				ferritisch und martensitisch <i>Ferritique et martensitique</i>			
	30% ae				30% ae			
DC mm	n min ⁻¹	Vf mm/min	ap mm	ae mm	n min ⁻¹	Vf mm/min	ap mm	ae mm
6	5358	911	9	1.8	4350	653	9	1.8
8	4019	764	12	2.4	3263	522	12	2.4
10	3215	804	15	3	2610	496	15	3
12	2679	844	18	3.6	2175	685	18	3.6

Material <i>Matière</i>	Rostfreier Stahl <i>Acier inoxydable</i>				Superlegierung <i>Superalliage</i>			
	austenitisch <i>Austénitique</i>				Titan <i>Titane</i>			
	30% ae				10% ae			
DC mm	n min ⁻¹	Vf mm/min	ap mm	ae mm	n min ⁻¹	Vf mm/min	ap mm	ae mm
6	6207	745	9	1.8	3661	494	9	0.6
8	4655	582	12	2.4	2745	398	12	0.8
10	3724	559	15	3	2196	373	15	1
12	3104	714	18	3.6	1830	522	18	1.2

Material <i>Matière</i>	Superlegierung <i>Superalliage</i>			
	Inconel <i>Inconel</i>			
	10% ae			
DC mm	n min ⁻¹	Vf mm/min	ap mm	ae mm
6	1645	173	9	0.6
8	1233	136	12	0.8
10	987	133	15	1
12	822	181	18	1.2



NEU
nouveaux

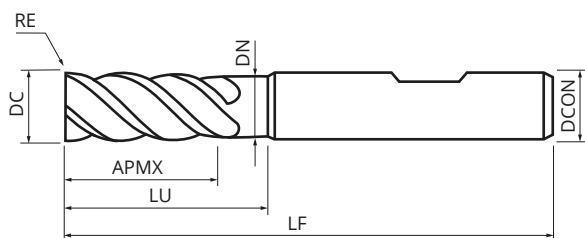

- Zur Anwendung in Stahl bis HRC 48 und Guss
Pour l'utilisation dans l'acier jusqu'à 48 HRC et la fonte
- 5° maximaler Ramping-Winkel *Angle de rampe max 5°*
- 5° maximaler Helix-Winkel *Angle helix max 5°*

ABMESSUNGEN *Dimensions*

Artikelnummer HB <i>Référence HB</i> (WGR. 7688)	Artikelnummer HA <i>Référence HA</i>	DC	APMX	LU	LF	DCON	DN	RE	ZEPF
		mm	mm	mm	mm	mm	mm	mm	
GRXFE 4030R03-HB	GRXFE 4030R03-HA	3	8	15	57	6	2.8	0.3	4
GRXFE 4030R05-HB	GRXFE 4030R05-HA	3	8	15	57	6	2.8	0.5	4
GRXFE 4040R02-HB	GRXFE 4040R02-HA	4	11	17	57	6	3.8	0.2	4
GRXFE 4040R05-HB	GRXFE 4040R05-HA	4	11	17	57	6	3.8	0.5	4
GRXFE 4040R10-HB	GRXFE 4040R10-HA	4	11	17	57	6	3.8	1	4
GRXFE 4050R05-HB	GRXFE 4050R05-HA	5	13	19	57	6	4.8	0.5	4
GRXFE 4050R10-HB	GRXFE 4050R10-HA	5	13	19	57	6	4.8	1	4
GRXFE 4060R05-HB	GRXFE 4060R05-HA	6	13	21	57	6	5.8	0.5	4
GRXFE 4060R10-HB	GRXFE 4060R10-HA	6	13	21	57	6	5.8	1	4
GRXFE 4060R20-HB	GRXFE 4060R20-HA	6	13	21	57	6	5.8	2	4
GRXFE 4080R05-HB	GRXFE 4080R05-HA	8	19	27	63	8	7.6	0.5	4
GRXFE 4080R10-HB	GRXFE 4080R10-HA	8	19	27	63	8	7.6	1	4
GRXFE 4080R15-HB	GRXFE 4080R15-HA	8	19	27	63	8	7.6	1.5	4
GRXFE 4080R20-HB	GRXFE 4080R20-HA	8	19	27	63	8	7.6	2	4
GRXFE 4100R05-HB	GRXFE 4100R05-HA	10	22	32	72	10	9.5	0.5	4
GRXFE 4100R10-HB	GRXFE 4100R10-HA	10	22	32	72	10	9.5	1	4
GRXFE 4100R15-HB	GRXFE 4100R15-HA	10	22	32	72	10	9.5	1.5	4
GRXFE 4100R20-HB	GRXFE 4100R20-HA	10	22	32	72	10	9.5	2	4
GRXFE 4120R05-HB	GRXFE 4120R05-HA	12	26	38	83	12	11.5	0.5	4
GRXFE 4120R10-HB	GRXFE 4120R10-HA	12	26	38	83	12	11.5	1	4
GRXFE 4120R15-HB	GRXFE 4120R15-HA	12	26	38	83	12	11.5	1.5	4
GRXFE 4120R20-HB	GRXFE 4120R20-HA	12	26	38	83	12	11.5	2	4
GRXFE 4120R30-HB	GRXFE 4120R30-HA	12	26	38	83	12	11.5	3	4
GRXFE 4160R05-HB	GRXFE 4160R05-HA	16	32	44	92	16	15.5	0.5	4
GRXFE 4160R10-HB	GRXFE 4160R10-HA	16	32	44	92	16	15.5	1	4
GRXFE 4160R20-HB	GRXFE 4160R20-HA	16	32	44	92	16	15.5	2	4
GRXFE 4160R30-HB	GRXFE 4160R30-HA	16	32	44	92	16	15.5	3	4
GRXFE 4160R40-HB	GRXFE 4160R40-HA	16	32	44	92	16	15.5	4	4
GRXFE 4200R05-HB	GRXFE 4200R05-HA	20	38	54	104	20	19.5	0.5	4
GRXFE 4200R10-HB	GRXFE 4200R10-HA	20	38	54	104	20	19.5	1	4
GRXFE 4200R20-HB	GRXFE 4200R20-HA	20	38	54	104	20	19.5	2	4
GRXFE 4200R30-HB	GRXFE 4200R30-HA	20	38	54	104	20	19.5	3	4

SCHNITTDATEN *Données de coupe*

Material <i>Matière</i>	Stahl / legierter Stahl <i>Acier / Acier allié</i>															
	< 850 N/mm ²								< 1300 N/mm ²							
	100% ae				15% ae				50% ae				15% ae			
DC mm	n min ⁻¹	Vf mm/min	ap mm	ae mm	n min ⁻¹	Vf mm/min	ap mm	ae mm	n min ⁻¹	Vf mm/min	ap mm	ae mm	n min ⁻¹	Vf mm/min	ap mm	ae mm
3	12700	600	3	3	15900	1970	6	0.45	8400	400	3	1.5	10600	1310	6	0.45
4	9500	760	4	4	11900	2380	8	0.6	6300	500	4	2	7900	1580	8	0.6
5	7600	760	5	5	9500	2430	10	0.75	5000	500	5	2.5	6300	1610	10	0.75
6	6300	750	6	6	7900	2460	12	0.9	4200	500	6	3	5300	1650	12	0.9
8	4700	750	8	8	5900	2450	16	1.2	3100	490	8	4	3900	1620	16	1.2
10	3800	760	10	10	4700	2420	20	1.5	2500	500	10	5	3100	1590	20	1.5
12	3100	740	12	12	3900	2410	24	1.8	2100	500	12	6	2600	1610	24	1.8
16	2300	730	16	16	2900	2370	30	2.4	1500	480	16	8	1900	1550	30	2.4
20	1900	760	20	20	2300	2300	36	3	1200	480	20	10	1500	1500	36	3

Material <i>Matière</i>	Grauguss <i>Fonte grise</i>															
	< 600 N/mm ²								> 600 N/mm ²							
	100% ae				15% ae				50% ae				15% ae			
DC mm	n min ⁻¹	Vf mm/min	ap mm	ae mm	n min ⁻¹	Vf mm/min	ap mm	ae mm	n min ⁻¹	Vf mm/min	ap mm	ae mm	n min ⁻¹	Vf mm/min	ap mm	ae mm
3	13700	650	3	3	16900	2090	6	0.45	7400	350	3	1.5	10000	1240	6	0.45
4	10300	820	4	4	12700	2540	8	0.6	5500	440	4	2	7500	1500	8	0.6
5	8200	820	5	5	10100	2580	10	0.75	4400	440	5	2.5	6000	1530	10	0.75
6	6800	810	6	6	8400	2620	12	0.9	3700	440	6	3	5000	1560	12	0.9
8	5100	810	8	8	6300	2620	16	1.2	2700	430	8	4	3700	1530	16	1.2
10	4100	820	10	10	5000	2580	20	1.5	2200	440	10	5	3000	1540	20	1.5
12	3400	810	12	12	4200	2600	24	1.8	1800	430	12	6	2500	1550	24	1.8
16	2500	800	16	16	3100	2540	30	2.4	1300	410	16	8	1800	1470	30	2.4
20	2000	800	20	20	2500	2500	36	3	1100	440	20	10	1500	1500	36	3

Material <i>Matière</i>	Gehärteter Stahl <i>Acier trempé</i>							
	HRC 44 - 48							
	30% ae				15% ae			
DC mm	n min ⁻¹	Vf mm/min	ap mm	ae mm	n min ⁻¹	Vf mm/min	ap mm	ae mm
3	5300	230	3	0.9	6300	390	6	0.45
4	3900	210	4	1.2	4700	370	8	0.6
5	3100	210	5	1.5	3800	370	10	0.75
6	2600	210	6	1.8	3100	370	12	0.9
8	1900	210	8	2.4	2300	370	16	1.2
10	1500	210	10	3	1900	370	20	1.5
12	1300	210	12	3.6	1500	370	24	1.8
16	900	200	16	4.8	1100	340	30	2.4
20	700	190	20	6	900	340	36	3



**NEUE*
MODELLE**
nouveaux
modèles

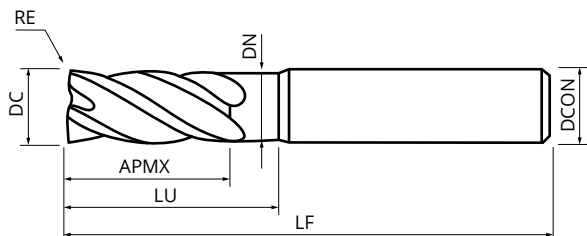

- Zur Anwendung in Stahl, gehärtetem Stahl und Kupfer *Pour l'utilisation dans l'acier trempé, l'acier et le cuivre*

DC	RE	Toleranzen Tolérances	
1 - 6	R0.2 - R2	0/-0.015 DC-TOL	±0.01 RE
8 - 20	R0.2 - R2	0/-0.02 DC-TOL	±0.01 RE

ABMESSUNGEN *Dimensions*

Artikelnummer Référence (WGR. 7683)	DC mm	APMX mm	LU mm	LF mm	DCON mm	DN mm	RE mm	ZEPF
GCRESN 4030R02	3	4.5	9	50	6	2.9	0.2	4
GCRESN 4030R05	3	4.5	9	50	6	2.9	0.5	4
GCRESN 4040R02	4	6	12	50	6	3.9	0.2	4
GCRESN 4040R05	4	6	12	50	6	3.9	0.5	4
GCRESN 4040R10	4	6	12	50	6	3.9	1.0	4
GCRESN 4050R02	5	7.5	15	50	6	4.8	0.2	4
GCRESN 4050R05	5	7.5	15	50	6	4.8	0.5	4
GCRESN 4050R10	5	7.5	15	50	6	4.8	1.0	4
* GCRESN 4060R02	6	9	18	50	6	5.7	0.2	4
GCRESN 4060R03	6	9	18	50	6	5.7	0.3	4
GCRESN 4060R05	6	9	18	50	6	5.7	0.5	4
GCRESN 4060R10	6	9	18	50	6	5.7	1.0	4
GCRESN 4060R15	6	9	18	50	6	5.7	1.5	4
* GCRESN 4080R02	8	12	24	60	8	7.6	0.2	4
GCRESN 4080R03	8	12	24	60	8	7.6	0.3	4
GCRESN 4080R05	8	12	24	60	8	7.6	0.5	4
GCRESN 4080R10	8	12	24	60	8	7.6	1.0	4
GCRESN 4080R20	8	12	24	60	8	7.6	2.0	4
GCRESN 4100R03	10	15	30	70	10	9.5	0.3	4
GCRESN 4100R05	10	15	30	70	10	9.5	0.5	4
GCRESN 4100R10	10	15	30	70	10	9.5	1.0	4
GCRESN 4100R15	10	15	30	70	10	9.5	1.5	4
GCRESN 4100R20	10	15	30	70	10	9.5	2.0	4
GCRESN 4120R03	12	20	36	80	12	11.5	0.3	4
GCRESN 4120R05	12	20	36	80	12	11.5	0.5	4
GCRESN 4120R10	12	20	36	80	12	11.5	1.0	4
GCRESN 4120R15	12	20	36	80	12	11.5	1.5	4
GCRESN 4120R20	12	20	36	80	12	11.5	2.0	4

ABMESSUNGEN *Dimensions*

Artikelnummer <i>Référence</i>	DC	APMX	LU	LF	DCON	DN	RE	ZEFP
(WGR. 7683)	mm	mm	mm	mm	mm	mm	mm	
GCRESN 4160R05	16	24	48	93	16	15	0.5	4
GCRESN 4160R10	16	24	48	93	16	15	1.0	4
GCRESN 4160R20	16	24	48	93	16	15	2.0	4
GCRESN 4200R05	20	30	60	105	20	19	0.5	4
GCRESN 4200R10	20	30	60	105	20	19	1.0	4
GCRESN 4200R20	20	30	60	105	20	19	2.0	4

SCHNITTDATEN *Données de coupe*

Material <i>Matière</i>	Kohlenstoffstahl <i>Acier carbone</i>											
	HB 180 - 250											
DC mm	Schruppen <i>Ébauche</i>				Schlichten 3D <i>Finition 3D</i>				Schlichten Planfräsen <i>Finition surfacage</i>			
	n min ⁻¹	Vf mm/min	ap mm	ae mm	n min ⁻¹	Vf mm/min	ap mm	ae mm	n min ⁻¹	Vf mm/min	ap mm	ae mm
3	19639	2150	4.5	0.3	27601	8280	0.033	0.067	17516	5255	0.057	1.2
4	14729	2200	6	0.4	20701	7866	0.033	0.067	13137	4992	0.057	1.6
5	11783	2200	5	0.5	16561	9274	0.033	0.067	10510	5885	0.057	2
6	9820	2553	6	0.6	13800	8832	0.092	0.183	8758	5605	0.155	2.4
8	7365	2504	8	0.8	10350	8901	0.041	0.082	6568	5649	0.069	3.2
10	5892	2828	10	1	8280	8943	0.106	0.212	5255	5675	0.179	4
12	4910	2650	18	1.2	6900	8556	0.041	0.082	4379	5430	0.069	4.8
16	3682	2651	24	1.6	5175	8280	0.106	0.212	3284	5255	0.179	6.4
20	2946	2357	30	2	4140	7452	0.106	0.212	2627	4729	0.179	8

Material <i>Matière</i>	Stahl <i>Acier</i>											
	HRC 25 - 34											
DC mm	Schruppen <i>Ébauche</i>				Schlichten 3D <i>Finition 3D</i>				Schlichten Planfräsen <i>Finition surfacage</i>			
	n min ⁻¹	Vf mm/min	ap mm	ae mm	n min ⁻¹	Vf mm/min	ap mm	ae mm	n min ⁻¹	Vf mm/min	ap mm	ae mm
3	17516	1611	4.05	0.252	21231	5096	0.033	0.067	15393	3694	0.057	1.2
4	13137	1734	5.4	0.336	15924	5414	0.033	0.067	11545	3925	0.057	1.6
5	10510	1810	4.5	0.42	12739	5096	0.033	0.067	9236	3694	0.057	2
6	8758	1927	5.4	0.504	10616	5096	0.092	0.183	7696	3694	0.155	2.4
8	6568	1708	7.2	0.672	7962	5255	0.041	0.082	5772	3810	0.069	3.2
10	5255	2207	9	0.84	6369	5605	0.106	0.212	4618	4064	0.179	4
12	4379	2250	13.2	1.008	5308	5945	0.041	0.082	3848	4310	0.069	4.8
16	3284	2233	17.6	1.344	3981	4777	0.106	0.212	2886	3463	0.179	6.4
20	2627	1944	22	1.68	3185	4204	0.106	0.212	2309	3048	0.179	8

SCHNITTDATEN *Données de coupe*

Material <i>Matière</i>	Vorgehärteter Stahl <i>Acier pré-trempé</i>											
	HRC 35 - 45											
	Schruppen <i>Ébauche</i>				Schichten 3D <i>Finition 3D</i>				Schichten Planfräsen <i>Finition surfacage</i>			
DC mm	n min ⁻¹	Vf mm/min	ap mm	ae mm	n min ⁻¹	Vf mm/min	ap mm	ae mm	n min ⁻¹	Vf mm/min	ap mm	ae mm
3	12208	1123	3.6	0.192	18047	3248	0.033	0.067	12739	2293	0.057	1.2
4	9156	1099	4.8	0.256	13535	3411	0.033	0.067	9554	2408	0.057	1.6
5	7325	1025	4	0.32	10828	3032	0.033	0.067	7643	2140	0.057	2
6	6104	1099	4.8	0.384	9023	3068	0.092	0.183	6369	2166	0.155	2.4
8	4578	1007	6.4	0.512	6768	2842	0.041	0.082	4777	2006	0.069	3.2
10	3662	1465	8	0.64	5414	3898	0.106	0.212	3822	2752	0.179	4
12	3850	1850	9.6	0.768	4512	3970	0.041	0.082	3185	2803	0.069	4.8
16	3850	2079	16	1.024	3384	3384	0.106	0.212	2389	2389	0.179	6.4
20	3850	2233	20	1.28	2707	2924	0.106	0.212	1911	2064	0.179	8

Material <i>Matière</i>	Gehärteter Stahl <i>Acier trempé</i>											
	HRC 46 - 55											
	Schruppen <i>Ébauche</i>				Schichten 3D <i>Finition 3D</i>				Schichten Planfräsen <i>Finition surfacage</i>			
DC mm	n min ⁻¹	Vf mm/min	ap mm	ae mm	n min ⁻¹	Vf mm/min	ap mm	ae mm	n min ⁻¹	Vf mm/min	ap mm	ae mm
3	5300	590	2.925	0.168	15393	2155	0.033	0.067	9023	1263	0.057	1.2
4	5300	590	3.9	0.224	11545	2540	0.033	0.067	6768	1489	0.057	1.6
5	4800	490	3.25	0.28	9236	2217	0.033	0.067	5414	1299	0.057	2
6	4777	764	3.9	0.336	7696	2155	0.092	0.183	4512	1263	0.155	2.4
8	3583	659	5.2	0.448	5772	2032	0.041	0.082	3384	1191	0.069	3.2
10	2866	1009	6.5	0.56	4618	2217	0.106	0.212	2707	1299	0.179	4
12	2389	1003	9.6	0.672	3848	2309	0.041	0.082	2256	1354	0.069	4.8
16	1791	752	16	0.896	2886	2136	0.106	0.212	1692	1252	0.179	6.4
20	1433	659	20	1.12	2309	1847	0.106	0.212	1354	1083	0.179	8

SCHNITTDATEN *Données de coupe*

Material <i>Matière</i>	Gehärteter Stahl <i>Acier trempé</i>											
	HRC 56 – 60											
DC mm	Schruppen <i>Ébauche</i>				Schichten 3D <i>Finition 3D</i>				Schichten Planfräsen <i>Finition surfacage</i>			
	n min ⁻¹	Vf mm/min	ap mm	ae mm	n min ⁻¹	Vf mm/min	ap mm	ae mm	n min ⁻¹	Vf mm/min	ap mm	ae mm
3	5300	500	2.7	0.12	11677	1401	0.033	0.067	3715	446	0.057	1.2
4	5300	500	3.6	0.16	8758	1576	0.033	0.067	2787	502	0.057	1.6
5	4800	450	3	0.2	7006	1401	0.033	0.067	2229	446	0.057	2
6	3450	386	3.6	0.24	5839	1425	0.092	0.183	1858	453	0.155	2.4
8	2588	342	4.8	0.32	4379	1226	0.041	0.082	1393	390	0.069	3.2
10	2070	233	6	0.4	3503	1261	0.106	0.212	1115	401	0.179	4
12	1730	850	9.6	0.48	2919	1168	0.041	0.082	929	372	0.069	4.8
16	1294	518	9.6	0.64	2189	1051	0.106	0.212	697	334	0.179	6.4
20	1035	455	12	0.8	1752	981	0.106	0.212	557	312	0.179	8

Material <i>Matière</i>	Kupfer <i>Cuivre</i>											
DC mm	Schruppen <i>Ébauche</i>				Schichten 3D <i>Finition 3D</i>				Schichten Planfräsen <i>Finition surfacage</i>			
	n min ⁻¹	Vf mm/min	ap mm	ae mm	n min ⁻¹	Vf mm/min	ap mm	ae mm	n min ⁻¹	Vf mm/min	ap mm	ae mm
3	21000	2300	5.4	0.168	30255	5446	0.033	0.067	18577	3344	0.057	1.05
4	15600	2304	7.2	0.192	22691	2304	0.033	0.067	13933	2304	0.057	1.4
5	12400	2350	6	0.24	18153	2350	0.033	0.067	11146	2350	0.057	1.75
6	10400	2650	7.2	0.288	15127	2650	0.092	0.183	9289	2650	0.155	2.1
8	10400	2650	9.6	0.384	11346	2650	0.041	0.082	6967	2650	0.069	2.8
10	6210	2484	12	0.48	9076	3631	0.106	0.212	5573	2229	0.179	3.5
12	5175	2484	14.4	0.576	7564	3631	0.041	0.082	4644	2229	0.069	4.2
16	3881	3105	19.2	0.768	5673	4538	0.106	0.212	3483	2787	0.179	5.6
20	3105	2732	24	0.96	4538	3994	0.106	0.212	2787	2452	0.179	7

GCRT 4000

VHM-Torusfräser – verstärkter Kern
Fraise torique en carbure – renforcée

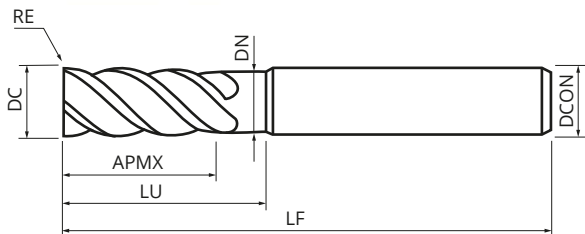

- Zur Anwendung in rostfreiem Stahl, Superlegierungen und Stahl bis HRC 45 *Pour l'utilisation dans l'acier inoxydable, les superalliages et l'acier jusqu'à 45 HRC*
- Mit verstärktem Kern für ausgezeichnete Performance bei Operationen bis $a_p = 1 \times D$
Avec âme renforcé pour une excellente performance lors des opération jusqu'à $a_p = 1 \times D$

ABMESSUNGEN *Dimensions*

Artikelnummer <i>Référence</i> (WGR. 7676)	DC mm	APMX mm	LU mm	LF mm	DCON mm	DN mm	RE mm	ZEPF
GCRT 4060R05	6	13	20	57	6	5.5	0.5	4
GCRT 4080R05	8	19	25	63	8	7.5	0.5	4
GCRT 4100R05	10	22	30	72	10	9.2	0.5	4
GCRT 4120R05	12	26	35	83	12	11	0.5	4

SCHNITTDATEN *Données de coupe*

Material <i>Matière</i>	Legierter Stahl <i>Acier allié</i>								Rostfreier Stahl <i>Acier inoxydable</i>							
	1000 - 1300 N/mm ²								ferritisch und martensitisch <i>Ferritique et martensitique</i>							
	100% ae				50% ae				100% ae				40% ae			
DC mm	n min ⁻¹	Vf mm/min	ap mm	ae mm	n min ⁻¹	Vf mm/min	ap mm	ae mm	n min ⁻¹	Vf mm/min	ap mm	ae mm	n min ⁻¹	Vf mm/min	ap mm	ae mm
6	6366	637	6	6	7958	796	6	2.4	4509	446	6	6	5570	550	6	2.4
8	4775	649	8	8	5968	836	8	3.2	3382	463	8	8	4178	572	8	3.2
10	3820	642	10	10	4775	802	10	4	2706	452	10	10	3342	559	10	4
12	3183	624	12	12	3979	780	12	4.8	2255	428	12	12	2785	529	12	4.8

Material <i>Matière</i>	Rostfreier Stahl <i>Acier inoxydable</i>								Superlegierung <i>Superalliage</i>							
	austenitisch <i>Austénitique</i>								Titan <i>Titane</i>							
	100% ae				40% ae				100% ae				40% ae			
DC mm	n min ⁻¹	Vf mm/min	ap mm	ae mm	n min ⁻¹	Vf mm/min	ap mm	ae mm	n min ⁻¹	Vf mm/min	ap mm	ae mm	n min ⁻¹	Vf mm/min	ap mm	ae mm
6	6631	907	6	6	8223	1125	6	2.4	2920	399	6	6	3720	508	6	2.4
8	4974	907	8	8	6167	1125	8	3.2	2190	399	8	8	2780	529	8	3.2
10	3979	907	10	10	4934	1125	10	4	1750	399	10	10	2230	508	10	4
12	3316	882	12	12	4112	1094	12	4.8	1460	388	12	12	1860	494	12	4.8

Material <i>Matière</i>	Superlegierung <i>Superalliage</i>							
	Inconel <i>Inconel</i>							
	100% ae				30% ae			
DC mm	n min ⁻¹	Vf mm/min	ap mm	ae mm	n min ⁻¹	Vf mm/min	ap mm	ae mm
6	1330	95	2.4	6	1698	136	3.6	1.8
8	1000	95	3.2	8	1273	132	4.8	2.4
10	800	95	4	10	1019	130	6	3
12	660	95	4.8	12	849	129	7.2	3.6

GCRT 5000

VHM-Torusfräser
Fraise torique en carbure

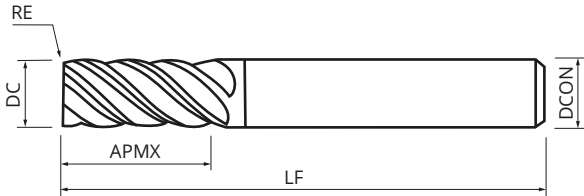

- Zur Anwendung in rostfreiem Stahl, Superlegierungen und Stahl bis HRC 45 *Pour l'utilisation dans l'acier inoxydable, les superalliages et l'acier jusqu'à 45 HRC*
- Spezielles Schneidendesign für HSC Bearbeitung *Design de coupe spécial pour l'usinage HSC*

ABMESSUNGEN *Dimensions*

Artikelnummer <i>Référence</i>	DC	APMX	LF	DCON	RE	ZEFP
(WGR. 7676)	mm	mm	mm	mm	mm	
GCRT 5060R03	6	13	57	6	0.3	5
GCRT 5080R05	8	19	63	8	0.5	5
GCRT 5100R05	10	22	72	10	0.5	5
GCRT 5120R05	12	26	83	12	0.5	5

SCHNITTDATEN *Données de coupe*

Material <i>Matière</i>	Stahl / legierter Stahl <i>Acier / Acier allié</i>				Rostfreier Stahl <i>Acier inoxydable</i>			
	< 1300 N/mm ²				ferritisch und martensitisch <i>Ferritique et martensitique</i>			
	30% ae				30% ae			
DC mm	n min ⁻¹	Vf mm/min	ap mm	ae mm	n min ⁻¹	Vf mm/min	ap mm	ae mm
6	5358	911	9	1.8	4350	653	9	1.8
8	4019	764	12	2.4	3263	522	12	2.4
10	3215	804	15	3	2610	496	15	3
12	2679	844	18	3.6	2175	685	18	3.6

Material <i>Matière</i>	Rostfreier Stahl <i>Acier inoxydable</i>				Superlegierung <i>Superalliage</i>			
	austenitisch <i>Austénitique</i>				Titan <i>Titane</i>			
	30% ae				10% ae			
DC mm	n min ⁻¹	Vf mm/min	ap mm	ae mm	n min ⁻¹	Vf mm/min	ap mm	ae mm
6	6207	745	9	1.8	3661	494	9	0.6
8	4655	582	12	2.4	2745	398	12	0.8
10	3724	559	15	3	2196	373	15	1
12	3104	714	18	3.6	1830	522	18	1.2

Material <i>Matière</i>	Superlegierung <i>Superalliage</i>			
	Inconel <i>Inconel</i>			
	10% ae			
DC mm	n min ⁻¹	Vf mm/min	ap mm	ae mm
6	1645	173	9	0.6
8	1233	136	12	0.8
10	987	133	15	1
12	822	181	18	1.2



DCON 2-6 0/-0.02 DCON 2-6 -0.01/-0.03

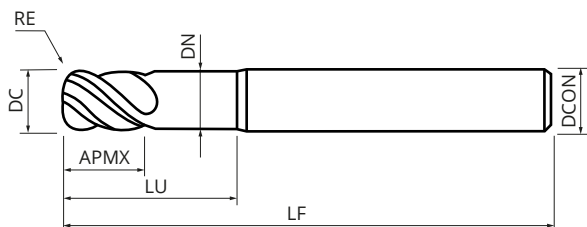

- Zur Anwendung in Stahl bis HRC 55, rostfreiem Stahl, Superlegierungen sowie Kupfer
Pour l'utilisation dans l'acier jusqu'à 55 HRC, l'acier inoxydable, les superalliages et le cuivre

ABMESSUNGEN *Dimensions*

Artikelnummer <i>Référence</i>	DC	APMX	LU	LF	DCON	DN	RE	ZEPF
(WGR. 7780)	mm	mm	mm	mm	mm	mm	mm	
GCR 4020-05-06	2	2	6	45	4	1.91	0.5	4
GCR 4030-05-12	3	3	12	60	6	2.92	0.5	4
GCR 4040-03-08	4	4	8	50	4	3.82	0.3	4
GCR 4040-05-12	4	4	12	50	6	3.82	0.5	4
GCR 4040-05-16	4	4	16	60	6	3.82	0.5	4
GCR 4060-05-18	6	6	18	60	6	5.82	0.5	4
GCR 4060-05-24L	6	6	24	90	6	5.82	0.5	4
GCR 4060-10-18	6	6	18	60	6	5.82	1.0	4
GCR 4060-10-24L	6	6	24	90	6	5.82	1.0	4
GCR 4080-05-26	8	8	26	70	8	7.82	0.5	4
GCR 4080-05-32L	8	8	32	100	8	7.82	0.5	4
GCR 4080-10-26	8	8	26	70	8	7.82	1.0	4
GCR 4080-10-32L	8	8	32	100	8	7.82	1.0	4
GCR 4080-15-24	8	8	24	70	8	7.82	1.5	4
GCR 4080-15-32L	8	8	32	100	8	7.82	1.5	4
GCR 4080-20-24	8	8	24	70	8	7.82	2.0	4
GCR 4080-20-32L	8	8	32	100	8	7.82	2.0	4
GCR 4100-05-30	10	10	30	80	10	9.82	0.5	4
GCR 4100-05-30L	10	10	30	120	10	9.82	0.5	4
GCR 4100-10-30	10	10	30	80	10	9.82	1.0	4
GCR 4100-10-40L	10	10	40	120	10	9.82	1.0	4
GCR 4100-15-30	10	10	30	80	10	9.82	1.5	4
GCR 4100-15-40L	10	10	40	120	10	9.82	1.5	4
GCR 4100-20-30	10	10	30	80	10	9.82	2.0	4
GCR 4100-20-40L	10	10	40	120	10	9.82	2.0	4
GCR 4100-30-30	10	10	30	80	10	9.82	3.0	4
GCR 4100-30-40L	10	10	40	120	10	9.82	3.0	4
GCR 4120-05-36	12	12	36	100	12	11.82	0.5	4
GCR 4120-05-48L	12	12	48	120	12	11.82	0.5	4
GCR 4120-10-36	12	12	36	100	12	11.82	1.0	4
GCR 4120-10-48L	12	12	48	120	12	11.82	1.0	4
GCR 4120-20-36	12	12	36	100	12	11.82	2.0	4
GCR 4120-20-48L	12	12	48	120	12	11.82	2.0	4
GCR 4120-30-36	12	12	36	100	12	11.82	3.0	4
GCR 4120-30-48L	12	12	48	120	12	11.82	3.0	4

SCHNITTDATEN *Données de coupe*

Material <i>Matière</i>			Stahl <i>Acier</i>							
			~ HRC 20 / ~ 800 N/mm ²							
			Schruppen <i>Ébauche</i>				Schlichten <i>Finition</i>			
Artikel <i>Article</i>	DC mm	RE mm	n min ⁻¹	Vf mm/min	ap mm	ae mm	n min ⁻¹	Vf mm/min	ap mm	ae mm
4020-05-06	2	0.5	30000	7200	0.08	0.8	30000	1720	0.1	0.06
4030-05-12	3	0.5	20000	8400	0.09	1.2	20000	1890	0.1	0.09
4040-03-08	4	0.3	15000	9600	0.09	1.6	15000	1050	0.1	0.07
4040-05-12 / 16	4	0.5	15000	9600	0.1	1.6	15000	1360	0.1	0.09
4060-05-18 / 24L	6	0.5	10000	12000	0.14	2.4	10000	1150	0.2	0.12
4060-10-18 / 24L	6	1.0	10000	12000	0.15	2.4	10000	1630	0.2	0.16
4080-05-26 / 32L	8	0.5	7500	12000	0.18	2.64	7500	990	0.2	0.13
4080-10-26 / 32L	8	1.0	7500	12000	0.2	2.72	7500	1410	0.2	0.19
4080-15-24 / 32L	8	1.5	7500	12000	0.22	2.8	7500	1650	0.2	0.23
4080-20-24 / 32L	8	2.0	7500	12000	0.24	2.88	7500	1990	0.2	0.27
4100-05-30 / 30L	10	0.5	6000	12000	0.22	3.04	6000	940	0.2	0.16
4100-10-30 / 40L	10	1.0	6000	12000	0.24	3.28	6000	1330	0.2	0.22
4100-15-30 / 40L	10	1.5	6000	12000	0.25	3.36	6000	1580	0.2	0.26
4100-20-30 / 40L	10	2.0	6000	12000	0.26	3.44	6000	1890	0.2	0.32
4100-30-30 / 40L	10	3.0	6000	12000	0.27	3.52	6000	2050	0.2	0.35
4120-05-36 / 48L	12	0.5	5000	12000	0.26	3.66	5000	1200	0.2	0.32
4120-10-36 / 48L	12	1.0	5000	12000	0.26	3.7	5000	1580	0.2	0.33
4120-20-36 / 48L	12	2.0	5000	12000	0.28	3.76	5000	1760	0.2	0.35
4120-30-36 / 48L	12	3.0	5000	12000	0.3	4	5000	1950	0.2	0.37

Material <i>Matière</i>			Legierter Stahl <i>Acier allié</i>							
			HRC 20 ~ 35 / 800 ~ 1100 N/mm ²							
			Schruppen <i>Ébauche</i>				Schlichten <i>Finition</i>			
Artikel <i>Article</i>	DC mm	RE mm	n min ⁻¹	Vf mm/min	ap mm	ae mm	n min ⁻¹	Vf mm/min	ap mm	ae mm
4020-05-06	2	0.5	30000	7200	0.04	0.66	30000	1510	0.05	0.05
4030-05-12	3	0.5	20000	7200	0.04	1.08	20000	1660	0.05	0.08
4040-03-08	4	0.3	15000	7200	0.05	1.32	15000	910	0.05	0.06
4040-05-12 / 16	4	0.5	15000	7200	0.05	1.35	15000	1180	0.05	0.08
4060-05-18 / 24L	6	0.5	10000	7200	0.07	1.98	10000	990	0.1	0.1
4060-10-18 / 24L	6	1.0	10000	7200	0.07	2.16	10000	1400	0.1	0.14
4080-05-26 / 32L	8	0.5	7500	7200	0.08	2.61	7500	860	0.1	0.11
4080-10-26 / 32L	8	1.0	7500	7200	0.09	2.74	7500	1210	0.1	0.16
4080-15-24 / 32L	8	1.5	7500	7200	0.09	2.74	7500	1530	0.1	0.2
4080-20-24 / 32L	8	2.0	7500	7200	0.1	2.79	7500	1720	0.1	0.23
4100-05-30 / 30L	10	0.5	5000	5400	0.14	2.88	5000	660	0.1	0.13
4100-10-30 / 40L	10	1.0	5000	5400	0.14	2.97	5000	940	0.1	0.19
4100-15-30 / 40L	10	1.5	5000	5400	0.14	3.01	5000	1050	0.1	0.24
4100-20-30 / 40L	10	2.0	5000	5400	0.14	3.06	5000	1340	0.1	0.27
4100-30-30 / 40L	10	3.0	5000	5400	0.14	3.08	5000	1560	0.1	0.3
4120-05-36 / 48L	12	0.5	3000	4320	0.18	3.15	3000	660	0.1	0.24
4120-10-36 / 48L	12	1.0	3000	4320	0.18	3.15	3000	720	0.1	0.27
4120-20-36 / 48L	12	2.0	3000	4320	0.18	3.15	3000	870	0.1	0.29
4120-30-36 / 48L	12	3.0	3000	4320	0.17	3.15	3000	1030	0.1	0.33

SCHNITTDATEN *Données de coupe*

Material <i>Matière</i>			Rostfreier Stahl <i>Acier inoxydable</i>							
			225 ~ 325 HB							
			Schruppen <i>Ébauche</i>				Schlichten <i>Finition</i>			
Artikel <i>Article</i>	DC mm	RE mm	n min ⁻¹	Vf mm/min	ap mm	ae mm	n min ⁻¹	Vf mm/min	ap mm	ae mm
4020-05-06	2	0.5	30000	7200	0.04	0.66	30000	1510	0.05	0.05
4030-05-12	3	0.5	20000	7200	0.04	1.08	20000	1660	0.05	0.08
4040-03-08	4	0.3	15000	7200	0.05	1.32	15000	910	0.05	0.06
4040-05-12 / 16	4	0.5	15000	7200	0.05	1.35	15000	1180	0.05	0.08
4060-05-18 / 24L	6	0.5	10000	7200	0.07	1.98	10000	990	0.1	0.1
4060-10-18 / 24L	6	1.0	10000	7200	0.07	2.16	10000	1400	0.1	0.14
4080-05-26 / 32L	8	0.5	7500	7200	0.08	2.61	7500	860	0.1	0.11
4080-10-26 / 32L	8	1.0	7500	7200	0.09	2.7	7500	1210	0.1	0.16
4080-15-24 / 32L	8	1.5	7500	7200	0.1	2.79	7500	1530	0.1	0.2
4080-20-24 / 32L	8	2.0	5000	5400	0.14	2.82	7500	1720	0.1	0.23
4100-05-30 / 30L	10	0.5	5000	5400	0.14	2.88	5000	660	0.1	0.13
4100-10-30 / 40L	10	1.0	5000	5400	0.14	2.97	5000	940	0.1	0.19
4100-15-30 / 40L	10	1.5	5000	5400	0.14	3.01	5000	1050	0.1	0.24
4100-20-30 / 40L	10	2.0	5000	5400	0.14	3.06	5000	1340	0.1	0.27
4100-30-30 / 40L	10	3.0	5000	5400	0.14	3.09	5000	1560	0.1	0.3
4120-05-36 / 48L	12	0.5	3000	4320	0.18	2.9	3000	660	0.1	0.24
4120-10-36 / 48L	12	1.0	3000	4320	0.18	2.96	3000	720	0.1	0.27
4120-20-36 / 48L	12	2.0	3000	4320	0.18	3.06	3000	870	0.1	0.29
4120-30-36 / 48L	12	3.0	3000	4320	0.18	3.15	3000	1030	0.1	0.33

Material <i>Matière</i>			Superlegierung <i>Superalliage</i>							
			Titan <i>Titane</i>							
			Schruppen <i>Ébauche</i>				Schlichten <i>Finition</i>			
Artikel <i>Article</i>	DC mm	RE mm	n min ⁻¹	Vf mm/min	ap mm	ae mm	n min ⁻¹	Vf mm/min	ap mm	ae mm
4020-05-06	2	0.5	21420	4010	0.03	0.33	21420	840	0.04	0.03
4030-05-12	3	0.5	14280	4010	0.03	0.54	14280	920	0.04	0.04
4040-03-08	4	0.3	10710	4010	0.04	0.66	10710	510	0.04	0.03
4040-05-12 / 16	4	0.5	10710	4010	0.04	0.68	10710	660	0.04	0.04
4060-05-18 / 24L	6	0.5	7140	4010	0.05	1	7140	550	0.07	0.05
4060-10-18 / 24L	6	1.0	7140	4010	0.05	1.08	7140	780	0.07	0.07
4080-05-26 / 32L	8	0.5	5360	4000	0.05	1.31	5360	400	0.06	0.04
4080-10-26 / 32L	8	1.0	5360	4000	0.05	1.35	5360	480	0.06	0.06
4080-15-24 / 32L	8	1.5	5360	4000	0.05	1.4	5360	670	0.06	0.08
4080-20-24 / 32L	8	2.0	3570	3010	0.09	1.41	5360	960	0.05	0.12
4100-05-30 / 30L	10	0.5	3570	3010	0.09	1.44	3570	280	0.06	0.05
4100-10-30 / 40L	10	1.0	3570	3010	0.09	1.49	3570	370	0.06	0.07
4100-15-30 / 40L	10	1.5	3570	3010	0.09	1.51	3570	520	0.06	0.1
4100-20-30 / 40L	10	2.0	3570	3010	0.09	1.53	3570	750	0.06	0.14
4100-30-30 / 40L	10	3.0	3570	3010	0.09	1.55	3571	750	0.06	0.16
4120-05-36 / 48L	12	0.5	2140	2400	0.12	1.45	2140	240	0.07	0.05
4120-10-36 / 48L	12	1.0	2140	2400	0.12	1.48	2140	310	0.07	0.07
4120-20-36 / 48L	12	2.0	2140	2400	0.12	1.53	2140	400	0.07	0.11
4120-30-36 / 48L	12	3.0	2140	2400	0.12	1.58	2140	520	0.07	0.17

SCHNITTDATEN *Données de coupe*

Material <i>Matière</i>			Superlegierung <i>Superalloye</i>							
			Inconel <i>Inconel</i>							
			Schruppen <i>Ébauche</i>				Schlichten <i>Finition</i>			
Artikel <i>Article</i>	DC mm	RE mm	n min ⁻¹	Vf mm/min	ap mm	ae mm	n min ⁻¹	Vf mm/min	ap mm	ae mm
4020-05-06	2	0.5	5140	810	0.03	0.33	5140	170	0.04	0.03
4030-05-12	3	0.5	3430	810	0.03	0.54	3430	190	0.04	0.04
4040-03-08	4	0.3	2570	810	0.04	0.66	2570	100	0.04	0.03
4040-05-12 / 16	4	0.5	2570	810	0.04	0.68	2570	130	0.04	0.04
4060-05-18 / 24L	6	0.5	1740	810	0.05	1	1740	110	0.07	0.05
4060-10-18 / 24L	6	1.0	1740	810	0.05	1.08	1740	160	0.07	0.07
4080-05-26 / 32L	8	0.5	1580	800	0.05	1.31	1580	80	0.06	0.04
4080-10-26 / 32L	8	1.0	1580	800	0.05	1.35	1580	100	0.06	0.06
4080-15-24 / 32L	8	1.5	1580	800	0.05	1.4	1580	130	0.06	0.08
4080-20-24 / 32L	8	2.0	1050	550	0.09	1.41	1580	190	0.05	0.12
4100-05-30 / 30L	10	0.5	1050	550	0.09	1.44	1050	50	0.06	0.05
4100-10-30 / 40L	10	1.0	1050	550	0.09	1.49	1050	70	0.06	0.07
4100-15-30 / 40L	10	1.5	1050	550	0.09	1.51	1050	100	0.06	0.1
4100-20-30 / 40L	10	2.0	1050	550	0.09	1.53	1050	140	0.06	0.14
4100-30-30 / 40L	10	3.0	1050	550	0.09	1.55	1051	140	0.06	0.16
4120-05-36 / 48L	12	0.5	640	410	0.12	1.45	640	40	0.07	0.05
4120-10-36 / 48L	12	1.0	640	410	0.12	1.48	640	50	0.07	0.07
4120-20-36 / 48L	12	2.0	640	410	0.12	1.53	640	70	0.07	0.12
4120-30-36 / 48L	12	3.0	640	410	0.12	1.58	640	100	0.07	0.17

Material <i>Matière</i>			Gehärteter Stahl <i>Acier trempé</i>							
			HRC 36 ~ 55 / 1100 ~ 1450 N/mm ²							
			Schruppen <i>Ébauche</i>				Schlichten <i>Finition</i>			
Artikel <i>Article</i>	DC mm	RE mm	n min ⁻¹	Vf mm/min	ap mm	ae mm	n min ⁻¹	Vf mm/min	ap mm	ae mm
4020-05-06	2	0.5	24000	7000	0.02	0.59	24000	1070	0.05	0.04
4030-05-12	3	0.5	16000	7000	0.04	0.88	16000	1160	0.05	0.07
4040-03-08	4	0.3	12000	7000	0.05	1.17	12000	620	0.05	0.05
4040-05-12 / 16	4	0.5	12000	7000	0.05	1.26	12000	810	0.05	0.07
4060-05-18 / 24L	6	0.5	8000	5250	0.07	1.75	8000	670	0.1	0.08
4060-10-18 / 24L	6	1.0	8000	5250	0.08	1.75	8000	950	0.1	0.12
4080-05-26 / 32L	8	0.5	6000	4100	0.14	1.76	6000	580	0.1	0.1
4080-10-26 / 32L	8	1.0	6000	4100	0.16	1.76	6000	830	0.1	0.14
4080-15-24 / 32L	8	1.5	6000	4100	0.17	1.84	6000	1040	0.1	0.17
4080-20-24 / 32L	8	2.0	6000	4100	0.18	1.96	6000	1170	0.1	0.2
4100-05-30 / 30L	10	0.5	4800	4100	0.18	2.03	4800	520	0.1	0.11
4100-10-30 / 40L	10	1.0	4800	4100	0.19	2.1	4800	740	0.1	0.15
4100-15-30 / 40L	10	1.5	4800	4100	0.19	2.25	4800	960	0.1	0.18
4100-20-30 / 40L	10	2.0	4800	4100	0.2	2.35	4800	1050	0.1	0.22
4100-30-30 / 40L	10	3.0	4800	4100	0.2	2.45	4800	1180	0.1	0.25
4120-05-36 / 48L	12	0.5	4000	4100	0.21	2.8	4000	690	0.1	0.18
4120-10-36 / 48L	12	1.0	4000	4100	0.21	2.8	4000	820	0.1	0.21
4120-20-36 / 48L	12	2.0	4000	4100	0.21	2.8	4000	960	0.1	0.24
4120-30-36 / 48L	12	3.0	4000	4100	0.21	2.8	4000	1080	0.1	0.27

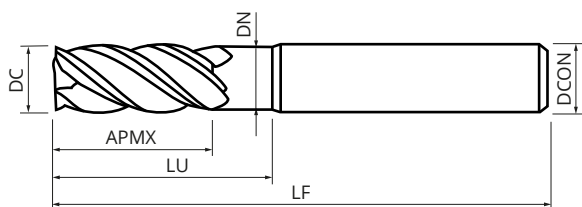

- Zur Anwendung in rostfreiem Stahl, Superlegierungen und Stahl *Pour l'utilisation dans l'acier inoxydable, les superalliages et l'acier*
- Mit extra scharfer Schneidkante *Avec arête de coupe extra-vive*

ABMESSUNGEN *Dimensions*

Artikelnummer <i>Référence</i>	DC	APMX	LU	LF	DCON	DN	ZEPF
(WGR. 7688)	mm	mm	mm	mm	mm	mm	
GSSVA 4025	2.5	8	14	57	6	2.3	4
GSSVA 4030	3	8	15	57	6	2.8	4
GSSVA 4040	4	9	15	57	6	3.8	4
GSSVA 4050	5	11	17	57	6	4.8	4
GSSVA 4060	6	13	21	57	6	5.8	4
GSSVA 4080	8	19	27	63	8	7.6	4
GSSVA 4100	10	22	32	72	10	9.5	4
GSSVA 4120	12	26	38	83	12	11.5	4

SCHNITTDATEN *Données de coupe*

Material <i>Matière</i>	Stahl / legierter Stahl <i>Acier / Acier allié</i>															
	< 850 N/mm								< 1300 N/mm							
	50% ae				15% ae				50% ae				15% ae			
DC mm	n min ⁻¹	Vf mm/min	ap mm	ae mm	n min ⁻¹	Vf mm/min	ap mm	ae mm	n min ⁻¹	Vf mm/min	ap mm	ae mm	n min ⁻¹	Vf mm/min	ap mm	ae mm
2.5	11200	538	5	1.25	13280	1856	5	0.38	6080	316	5	1.25	9200	1216	5	0.38
3	10160	608	6	1.5	12720	1928	6	0.45	5040	296	6	1.5	7600	1152	6	0.45
4	7600	608	8	2	9520	1904	8	0.6	3760	296	8	2	5680	1136	8	0.6
5	6080	608	10	2.5	7600	1976	10	0.75	3040	304	10	2.5	4560	1184	10	0.75
6	5040	600	12	3	6320	1968	12	0.9	2480	296	12	3	3760	1168	12	0.9
8	3760	600	16	4	4720	1960	16	1.2	1840	288	16	4	2800	1160	16	1.2
10	3040	608	20	5	3760	1936	20	1.5	1520	304	20	5	2240	1152	20	1.5
12	2480	592	24	6	3120	1928	24	1.8	1200	288	24	6	1840	1136	24	1.8

Material <i>Matière</i>	Rostfrei Austenitisch <i>Acier austenitique</i>															
	< 600 N/mm								600 - 800 N/mm							
	50% ae				15% ae				50% ae				15% ae			
DC mm	n min ⁻¹	Vf mm/min	ap mm	ae mm	n min ⁻¹	Vf mm/min	ap mm	ae mm	n min ⁻¹	Vf mm/min	ap mm	ae mm	n min ⁻¹	Vf mm/min	ap mm	ae mm
2.5	9680	536	5	1.25	12240	1680	5	0.38	7640	392	5	1.25	10240	1432	5	0.38
3	8000	480	6	1.5	10160	1544	6	0.45	6320	376	6	1.5	8480	1288	6	0.45
4	6000	480	8	2	7600	1520	8	0.6	4720	376	8	2	6320	1264	8	0.6
5	4800	480	10	2.5	6080	1576	10	0.75	3760	376	10	2.5	5040	1304	10	0.75
6	4000	480	12	3	5040	1568	12	0.9	3120	368	12	3	4240	1320	12	0.9
8	2960	472	16	4	3760	1560	16	1.2	2320	368	16	4	3120	1296	16	1.2
10	2400	480	20	5	3040	1568	20	1.5	1840	368	20	5	2480	1272	20	1.5
12	2000	480	24	6	2480	1536	24	1.8	1520	360	24	6	2080	1288	24	1.8

Material <i>Matière</i>	Duplex <i>Duplex</i>								Titan <i>Titane</i>							
	< 800 N/mm								900 - 1600 N/mm							
	30% ae				10% ae				30% ae				10% ae			
DC mm	n min ⁻¹	Vf mm/min	ap mm	ae mm	n min ⁻¹	Vf mm/min	ap mm	ae mm	n min ⁻¹	Vf mm/min	ap mm	ae mm	n min ⁻¹	Vf mm/min	ap mm	ae mm
2.5	6112	268	5	0.75	8160	620	6	0.25	5096	164	5	0.75	7120	428	6	0.25
3	5040	240	6	0.9	6720	560	8	0.3	4240	168	6	0.9	5920	400	8	0.3
4	3760	240	8	1.2	5040	584	10	0.4	3120	168	8	1.2	4400	416	10	0.4
5	3040	240	10	1.5	4000	592	12	0.5	2480	168	10	1.5	3520	416	12	0.5
6	2480	232	12	1.8	3360	576	16	0.6	2080	168	12	1.8	2960	408	16	0.6
8	1840	232	16	2.4	2480	568	20	0.8	1520	168	16	2.4	2160	416	20	0.8
10	1520	240	20	3	2000	592	24	1	1200	168	20	3	1760	416	24	1
12	1200	224	24	3.6	1680	568	30	1.2	1040	168	24	3.6	1440	432	30	1.2

GS 4000

VHM-Schaftfräser – bis HRC 55
Fraise cylindrique en carbure – jusqu'à 55 HRC

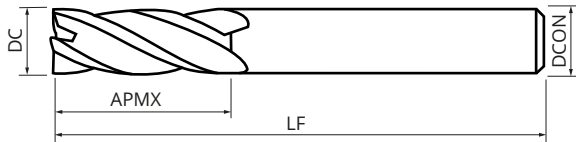

- Zur Anwendung in Stahl bis HRC 55
Pour l'utilisation dans l'acier jusqu'à 55 HRC

ABMESSUNGEN *Dimensions*

Artikelnummer <i>Référence</i> (WGR. 7780)	DC mm	APMX mm	LF mm	DCON mm	ZEFP
GS 4010	1	2.5	45	4	4
GS 4015	1.5	3.75	45	4	4
GS 4020	2	5	45	4	4
GS 4030	3	8	45	6	4
GS 4040	4	11	45	6	4
GS 4060	6	15	60	6	4
GS 4080	8	19	60	8	4
GS 4100	10	25	70	10	4

SCHNITTDATEN *Données de coupe*

Material <i>Matière</i>	Stahl <i>Acier</i>								Legierter Stahl <i>Acier allié</i>							
	~ HRC 20 / ~ 800 N/mm ²								HRC 20 ~ 35 / 800 ~ 1100 N/mm ²							
	Standard Fräsbearbeitung <i>Fraisage standard</i>				HSC Fräsen <i>Fraisage HSC</i>				Standard Fräsbearbeitung <i>Fraisage standard</i>				HSC Fräsen <i>Fraisage HSC</i>			
DC mm	n min ⁻¹	Vf mm/min	ap mm	ae mm	n min ⁻¹	Vf mm/min	ap mm	ae mm	n min ⁻¹	Vf mm/min	ap mm	ae mm	n min ⁻¹	Vf mm/min	ap mm	ae mm
1	20000	240	2.5	0.05	-	-	-	-	15000	215	2.5	0.05	-	-	-	-
1.5	13500	245	3.75	0.075	-	-	-	-	10000	215	3.75	0.075	-	-	-	-
2	1100	245	5	0.1	-	-	-	-	8500	215	5	0.1	-	-	-	-
3	7400	370	7.5	0.15	30000	1500	7.5	0.15	6400	260	7.5	0.15	26500	1075	7.5	0.15
4	5900	435	10	0.2	23800	1755	10	0.2	5000	340	10	0.2	19800	1345	10	0.2
6	4400	580	15	0.3	15900	2095	15	0.3	3500	415	15	0.3	13200	1565	15	0.3
8	3300	550	20	0.4	11900	1958	20	0.4	2600	415	20	0.4	9900	1580	20	0.4
10	2600	525	25	0.5	9500	1920	25	0.5	2100	405	25	0.5	7900	1525	25	0.5

Material <i>Matière</i>	Hitzbeständiger Stahl <i>Acier résistant à la chaleur</i>								Gehärteter Stahl <i>Acier trempé</i>							
	HRC 30 - 45								HRC 46 - 55							
	Standard Fräsbearbeitung <i>Fraisage standard</i>				HSC Fräsen <i>Fraisage HSC</i>				Standard Fräsbearbeitung <i>Fraisage standard</i>				HSC Fräsen <i>Fraisage HSC</i>			
DC mm	n min ⁻¹	Vf mm/min	ap mm	ae mm	n min ⁻¹	Vf mm/min	ap mm	ae mm	n min ⁻¹	Vf mm/min	ap mm	ae mm	n min ⁻¹	Vf mm/min	ap mm	ae mm
1	11000	85	2.5	0.05	-	-	-	-	7100	40	0.02	0.59	-	-	-	-
1.5	8000	90	3.75	0.075	-	-	-	-	5100	50	0.04	0.88	-	-	-	-
2	6400	90	5	0.1	-	-	-	-	4000	55	0.05	1.17	-	-	-	-
3	4500	105	7.5	0.15	21200	495	7.5	0.15	2800	65	0.05	1.26	15800	365	0.05	0.07
4	3500	120	10	0.2	15800	540	10	0.2	2150	70	0.07	1.75	11900	385	0.1	0.08
6	2450	130	15	0.3	10600	560	15	0.3	1500	70	0.08	1.75	7900	370	0.1	0.12
8	1850	125	20	0.4	7900	535	20	0.4	1200	70	0.14	1.76	5900	345	0.1	0.1
10	1450	125	25	0.5	6300	545	25	0.5	950	65	0.16	1.76	4700	320	0.1	0.14

GSWMN 3000

VHM-Schaftfräser
Fraise cylindrique en carbure

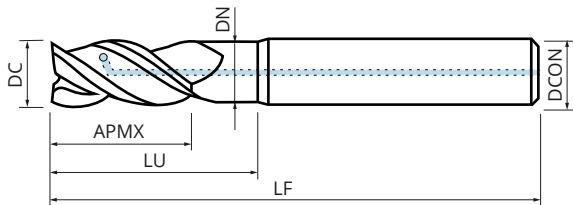

- Zur Anwendung in Aluminium, Kupfer und Messing *Pour l'utilisation dans l'aluminium, le cuivre et le laiton*
- Poliertes Hochleistungswerkzeug *Outil d'haute performance poli*
- Mit radialer Innenkühlung *Avec refroidissement interne radiale*

ABMESSUNGEN *Dimensions*

Artikelnummer <i>Référence</i>	DC	APMX	LU	LF	DCON	DN	ZEPF
(WGR. 7685)	mm	mm	mm	mm	mm	mm	
GSWMN 3040-IKR	4	8	12	58	6	3.9	3
GSWMN 3060-IKR	6	12	18	58	6	5.7	3
GSWMN 3080-IKR	8	16	24	64	8	7.6	3
GSWMN 3100-IKR	10	20	30	73	10	9.5	3
GSWMN 3120-IKR	12	24	36	84	12	11.7	3

SCHNITTDATEN *Données de coupe*

Material <i>Matière</i>	Aluminium < 6% Si <i>Aluminium < 6% Si</i>										
	Nutfräsen <i>Rainurage</i>			Umfangsfräsen <i>Contournage</i>				Schlichten <i>Finition</i>			
DC mm	n min ⁻¹	Vf mm/min	ap mm	n min ⁻¹	Vf mm/min	ap mm	ae mm	n min ⁻¹	Vf mm/min	ap mm	ae mm
4	15900	1330	3	23800	2570	6	2	28600	5490	8	0.11
6	10600	1330	6	15900	2620	9	3	19000	5520	12	0.17
8	7900	1320	8	11900	2600	12	4	14300	5530	16	0.22
10	6300	1320	10	9500	2590	15	5	11400	5500	20	0.28
12	5300	1330	12	7900	2580	18	6	9500	5500	24	0.34

Material <i>Matière</i>	Aluminium > 6% Si <i>Aluminium > 6% Si</i>										
	Nutfräsen <i>Rainurage</i>			Umfangsfräsen <i>Contournage</i>				Schlichten <i>Finition</i>			
DC mm	n min ⁻¹	Vf mm/min	ap mm	n min ⁻¹	Vf mm/min	ap mm	ae mm	n min ⁻¹	Vf mm/min	ap mm	ae mm
4	9500	570	4	14300	1110	6	1.6	17100	2300	8	0.1
6	6300	560	6	9500	1110	9	2.4	11400	2320	12	0.15
8	4700	560	8	7100	1100	12	3.2	8500	2290	16	0.2
10	3800	570	10	5700	1110	15	4	6800	2300	20	0.25
12	3100	550	12	4700	1090	18	4.8	5700	2300	24	0.3

Material <i>Matière</i>	Kupfer <i>Cuivre</i>										
	Nutfräsen <i>Rainurage</i>			Umfangsfräsen <i>Contournage</i>				Schlichten <i>Finition</i>			
DC mm	n min ⁻¹	Vf mm/min	ap mm	n min ⁻¹	Vf mm/min	ap mm	ae mm	n min ⁻¹	Vf mm/min	ap mm	ae mm
4	7900	470	4	11900	920	6	1.6	14300	1930	8	0.1
6	5300	470	6	7900	920	9	2.4	9500	1930	12	0.15
8	3900	460	8	5900	920	12	3.2	7100	1910	16	0.2
10	3100	460	10	4700	910	15	4	5700	1930	20	0.25
12	2600	460	12	3900	910	18	4.8	4700	1900	24	0.3

Material <i>Matière</i>	Messing <i>Laiton</i>										
	Nutfräsen <i>Rainurage</i>			Umfangsfräsen <i>Contournage</i>				Schlichten <i>Finition</i>			
DC mm	n min ⁻¹	Vf mm/min	ap mm	n min ⁻¹	Vf mm/min	ap mm	ae mm	n min ⁻¹	Vf mm/min	ap mm	ae mm
4	7900	710	8	11900	1390	8	1.6	14300	2910	8	0.1
6	5300	710	12	7900	1390	12	2.4	9500	2870	12	0.15
8	3900	700	16	5900	1380	16	3.2	7100	2870	16	0.2
10	3100	690	20	4700	1380	20	4	5700	2880	20	0.25
12	2600	700	24	3900	1360	24	4.8	4700	2860	24	0.3



NEU
nouveaux

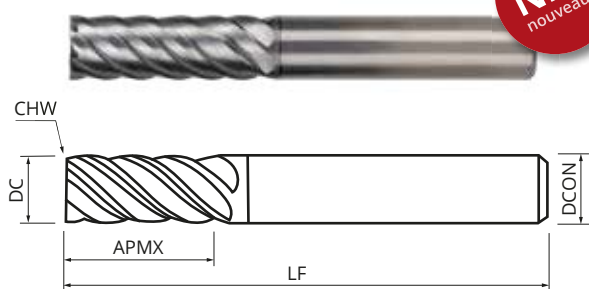

- Besonders gut geeignet für Feinschlicht-Bearbeitungen *Parfaitement adapté pour l'usage de finition*
- <5 µm Verjüngung für exakte Winkelgenauigkeit und Planparallelität *Conicité < a 5 µm pour une plus grande précision angulaire et un parallélisme des plans*

ABMESSUNGEN *Dimensions*

Artikelnummer <i>Référence</i> (WGR. 7688)	DC	APMX	LF	DCON	CHW	ZEFP
	mm	mm	mm	mm	mm	
FCZM 6030-HP	3	8	57	6	0.05	6
FCZM 6040-HP	4	11	57	6	0.05	6
FCZM 6050-HP	5	13	57	6	0.05	6
FCZM 6060-HP	6	13	57	6	0.05	6
FCZM 6080-HP	8	19	63	8	0.1	6
FCZM 6100-HP	10	22	72	10	0.1	6
FCZM 6120-HP	12	26	83	12	0.1	6
FCZM 6160-HP	16	32	92	16	0.15	6
FCZM 8200-HP	20	38	104	20	0.15	8

SCHNITTDATEN *Données de coupe*

Material <i>Matière</i>	Stahl / legierter Stahl <i>Acier / Acier allié</i>						Rostfrei Austenitisch <i>Acier austenitique</i>		
	< 850 N/mm ²			< 1300 N/mm ²			< 600 N/mm ²		
DC mm	n min ⁻¹	Vf mm/min	ae mm	n min ⁻¹	Vf mm/min	ae mm	n min ⁻¹	Vf mm/min	ae mm
3	19110	1150	0.15	16990	510	0.15	11680	180	0.15
4	15930	1440	0.15	12740	770	0.15	8760	270	0.15
5	14020	1690	0.15	10200	920	0.15	7010	320	0.15
6	11680	1760	0.2	8500	1020	0.2	5840	440	0.2
8	8760	2110	0.2	6370	1150	0.2	4380	530	0.2
10	7010	2110	0.2	5100	1230	0.2	3510	580	0.2
12	5840	2110	0.2	4250	1150	0.2	2920	620	0.2
16	4380	1840	0.2	3190	960	0.2	2190	560	0.2
20	3510	2250	0.2	2550	1130	0.2	1760	670	0.2

Material <i>Matière</i>	Rostfrei Austenitisch <i>Acier austenitique</i>			Titan <i>Titane</i>		
	600 - 800 N/mm ²			900 - 1100 N/mm ²		
DC mm	n min ⁻¹	Vf mm/min	ae mm	n min ⁻¹	Vf mm/min	ae mm
3	10090	160	0.15	9560	90	0.15
4	7570	230	0.15	7170	200	0.15
5	6060	280	0.15	5740	210	0.15
6	5050	380	0.2	4780	290	0.2
8	3790	460	0.2	3590	330	0.2
10	3030	500	0.2	2870	350	0.2
12	2530	540	0.2	2390	360	0.2
16	1900	490	0.2	1800	360	0.2
20	1520	580	0.2	1440	470	0.2

HSC



4-6

ZEPF



HA



SST

COAT



NEU
nouveaux

P

H

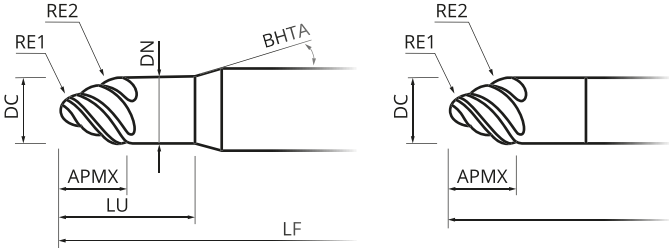

- Besonders gut geeignet für das effiziente Vorschlichten und Schlichten von Stahl bis HRC 65
Parfaitement adapté pour la préfinition et la finition efficace de l'acier jusqu'à HRC 65
- 25° Anstellwinkel *Angle d'attaque 25°*

ABMESSUNGEN *Dimensions*

Artikelnummer <i>Référence</i>	DC	RE1	RE2	APMX	LU	BHTA	LF	DCON	ZEPF	Abb.
(WGR. 7683)	mm	mm	mm	mm	mm	°	mm	mm		
HBCBC 4050-08-40	5	0.8	40	4.49	8.3	16	50	6	4	1
HBCBC 4080-15-100	8	1.5	100	6.9	-	-	55	8	4	2
HBCBC 6080-15-100	8	1.5	100	6.9	-	-	55	8	6	2
HBCBC 4100-20-160	10	2	160	8.43	20	16	70	12	4	1
HBCBC 6100-20-160	10	2	160	8.43	20	16	70	12	6	1

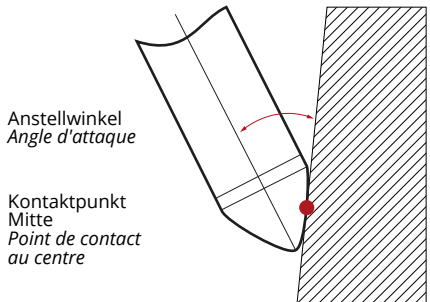

RE-Toleranz <i>Tolérance RE</i>	
RE 1 ≤ 2	RE 2 ≤ 160
± 0.01	± 0.01

SCHNITTDATEN *Données de coupe*

Material <i>Matière</i>		Kohlenstoffstahl <i>Acier carbone</i>											
		HB 180 – 250											
		Schruppen <i>Ébauche</i>				Schichten mit RE2 <i>Finition avec RE2</i>				Schichten mit RE1 <i>Finition avec RE1</i>			
DC	ZEFP	n	Vf	ap	ae	n	Vf	ap	ae	n	Vf	ap	ae
mm		min ⁻¹	mm/min	mm	mm	min ⁻¹	mm/min	mm	mm	min ⁻¹	mm/min	mm	mm
5	4	14100	3090	0.9	0.4	15500	2040	0.47	0.07	16900	2230	0.1	0.12
8	4	8800	3160	1.3	0.6	9700	2090	0.75	0.09	10600	2280	0.13	0.15
10	4	7100	3230	1.4	0.7	7800	2130	0.95	0.1	8500	2330	0.15	0.18
8	6	8800	4730	1.3	0.3	9700	3130	0.75	0.09	10600	2280	0.13	0.15
10	6	7100	4840	1.4	0.35	7800	3200	0.95	0.1	8500	2330	0.15	0.18

Material <i>Matière</i>		Stahl <i>Acier</i>											
		HRC 25 – 34											
		Schruppen <i>Ébauche</i>				Schichten mit RE2 <i>Finition avec RE2</i>				Schichten mit RE1 <i>Finition avec RE1</i>			
DC	ZEFP	n	Vf	ap	ae	n	Vf	ap	ae	n	Vf	ap	ae
mm		min ⁻¹	mm/min	mm	mm	min ⁻¹	mm/min	mm	mm	min ⁻¹	mm/min	mm	mm
5	4	12800	2530	0.86	0.4	13900	1650	0.47	0.07	15200	1810	0.1	0.12
8	4	8000	2580	1.24	0.6	8700	1690	0.75	0.09	9500	1850	0.13	0.15
10	4	6400	2640	1.33	0.7	7000	1730	0.95	0.1	7600	1890	0.15	0.18
8	6	8000	3870	1.24	0.3	8700	2530	0.75	0.09	9500	1850	0.13	0.15
10	6	6400	3960	1.33	0.35	7000	2590	0.95	0.1	7600	1890	0.15	0.18

Material <i>Matière</i>		Vorgehärteter Stahl <i>Acier pré-trempé</i>											
		HRC 35 – 45											
		Schruppen <i>Ébauche</i>				Schichten mit RE2 <i>Finition avec RE2</i>				Schichten mit RE1 <i>Finition avec RE1</i>			
DC	ZEFP	n	Vf	ap	ae	n	Vf	ap	ae	n	Vf	ap	ae
mm		min ⁻¹	mm/min	mm	mm	min ⁻¹	mm/min	mm	mm	min ⁻¹	mm/min	mm	mm
5	4	11800	2100	0.81	0.4	12500	1340	0.47	0.07	13700	1470	0.1	0.12
8	4	7400	2150	1.17	0.6	7900	1370	0.75	0.09	8600	1500	0.13	0.15
10	4	5900	2200	1.26	0.7	6300	1400	0.95	0.1	6900	1530	0.15	0.18
8	6	7400	3230	1.17	0.3	7900	2050	0.75	0.09	8600	1500	0.13	0.15
10	6	5900	3300	1.26	0.35	6300	2100	0.95	0.1	6900	1530	0.15	0.18

SCHNITTDATEN *Données de coupe*

Material <i>Matière</i>		Gehärteter Stahl <i>Acier trempé</i>											
		HRC 46 – 55											
		Schruppen <i>Ébauche</i>				Schlichten mit RE2 <i>Finition avec RE2</i>				Schlichten mit RE1 <i>Finition avec RE1</i>			
DC	ZEFP	n	Vf	ap	ae	n	Vf	ap	ae	n	Vf	ap	ae
mm		min ⁻¹	mm/min	mm	mm	min ⁻¹	mm/min	mm	mm	min ⁻¹	mm/min	mm	mm
5	4	10600	1690	0.77	0.32	11300	1090	0.47	0.06	12400	1190	0.1	0.1
8	4	6600	1730	1.11	0.48	7100	1110	0.75	0.07	7700	1220	0.13	0.12
10	4	5300	1770	1.2	0.56	5700	1140	0.95	0.08	6200	1240	0.15	0.14
8	6	6600	2590	1.11	0.24	7100	1660	0.75	0.07	7700	1220	0.13	0.12
10	6	5300	2650	1.2	0.28	5700	1700	0.95	0.08	6200	1240	0.15	0.14

Material <i>Matière</i>		Gehärteter Stahl <i>Acier trempé</i>											
		HRC 56 – 64											
		Schruppen <i>Ébauche</i>				Schlichten mit RE2 <i>Finition avec RE2</i>				Schlichten mit RE1 <i>Finition avec RE1</i>			
DC	ZEFP	n	Vf	ap	ae	n	Vf	ap	ae	n	Vf	ap	ae
mm		min ⁻¹	mm/min	mm	mm	min ⁻¹	mm/min	mm	mm	min ⁻¹	mm/min	mm	mm
5	4	8600	1250	0.69	0.28	10200	880	0.47	0.05	11100	960	0.1	0.08
8	4	5400	1270	1	0.42	6400	900	0.75	0.06	7000	990	0.13	0.12
10	4	4300	1300	1.08	0.49	5100	920	0.95	0.07	5600	1010	0.15	0.14
8	6	5400	1910	1	0.21	6400	1350	0.75	0.06	7000	990	0.13	0.12
10	6	4300	1950	1.08	0.25	5100	1380	0.95	0.07	5600	1010	0.15	0.14

Material <i>Matière</i>		Gehärteter Stahl <i>Acier trempé</i>											
		HRC 65 – 70											
		Schruppen <i>Ébauche</i>				Schlichten mit RE2 <i>Finition avec RE2</i>				Schlichten mit RE1 <i>Finition avec RE1</i>			
DC	ZEFP	n	Vf	ap	ae	n	Vf	ap	ae	n	Vf	ap	ae
mm		min ⁻¹	mm/min	mm	mm	min ⁻¹	mm/min	mm	mm	min ⁻¹	mm/min	mm	mm
5	4	7100	920	0.63	0.24	7600	600	0.47	0.04	8400	650	0.1	0.07
8	4	4400	940	0.9	0.36	4800	610	0.75	0.05	5200	670	0.13	0.09
10	4	3600	960	0.97	0.42	3800	620	0.95	0.06	4200	680	0.15	0.11
8	6	4400	1400	0.9	0.18	4800	910	0.75	0.05	5200	670	0.13	0.09
10	6	3600	1430	0.97	0.21	3800	930	0.95	0.06	4200	680	0.15	0.11

Bearbeitung mit RE2 *Usinages avec RE2*

Bearbeitung mit RE1 *Usinages avec RE1*

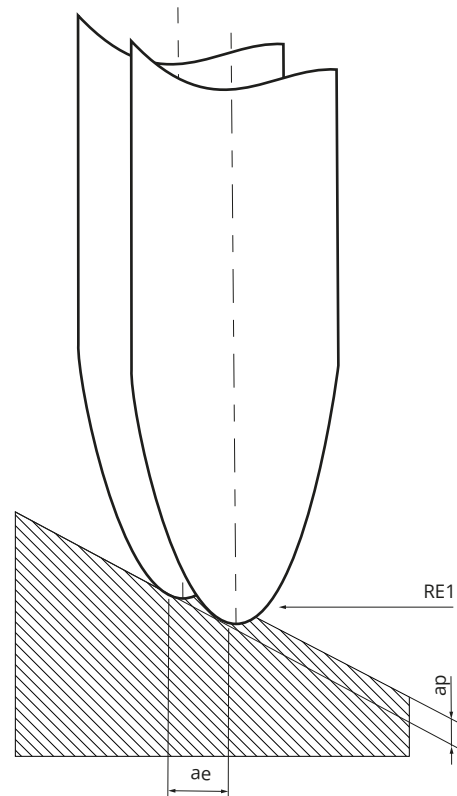
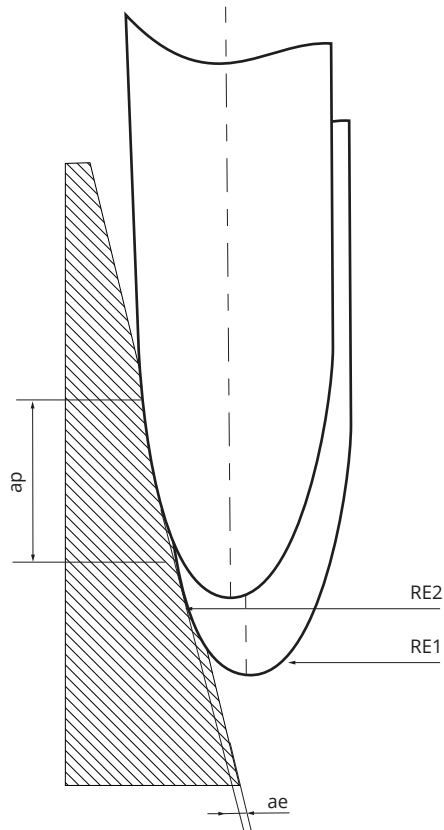

HSC



4-6

ZEPF



HA



SST

COAT

NEU
nouveaux

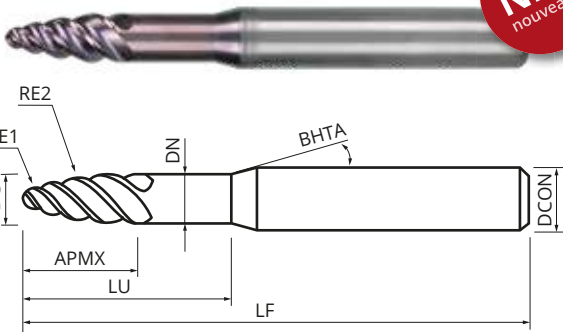

P

H

- Besonders gut geeignet für das effiziente Vorschlichten und Schlichten von Stahl bis HRC 65
Parfaitement adapté pour la pré finition et la finition efficace de l'acier jusqu'à HRC 65
- 9.15° Anstellwinkel *Angle d'attaque 9.15°*

ABMESSUNGEN *Dimensions*

Artikelnummer <i>Référence</i>	DC	RE1	RE2	APMX	LU	BHTA	LF	DCON	DN	ZEPF
(WGR. 7683)	mm	mm	mm	mm	mm	°	mm	mm	mm	
HBTBC 4030-05-20	3	0.5	20	6.73	10	15	50	4	2.9	4
HBTBC 4050-10-40	5	1	40	10.32	20	15	60	6	4.8	4
HBTBC 4075-15-60	7.5	1.5	60	15.53	30	15	75	8	7.3	4
HBTBC 6075-15-60	7.5	1.5	60	15.53	30	15	75	8	7.3	6
HBTBC 4100-20-80	10	2	80	20.7	40	15	100	12	9.5	4
HBTBC 6100-20-80	10	2	80	20.7	40	15	100	12	9.5	6

Anstellwinkel
Angle d'attaque

Kontaktpunkt
Mitte
*Point de contact
au centre*

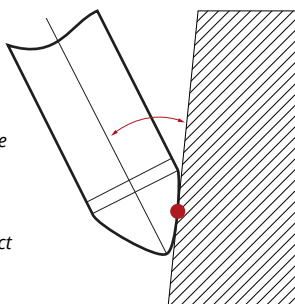

RE-Toleranz *Tolérance RE*

RE 1 ≤ 2	RE 2 ≤ 160
± 0.01	± 0.01

SCHNITTDATEN *Données de coupe*

Material <i>Matière</i>		Kohlenstoffstahl <i>Acier carbone</i>											
		HB 180 – 250											
		Schruppen <i>Ébauche</i>				Schlichten mit RE2 <i>Finition avec RE2</i>				Schlichten mit RE1 <i>Finition avec RE1</i>			
DC	ZEFP	n	Vf	ap	ae	n	Vf	ap	ae	n	Vf	ap	ae
mm		min ⁻¹	mm/min	mm	mm	min ⁻¹	mm/min	mm	mm	min ⁻¹	mm/min	mm	mm
3	4	23400	2810	0.6	0.2	25700	1850	0.33	0.055	28200	2030	0.07	0.07
5	4	14100	3090	0.9	0.4	15500	2040	0.47	0.07	16900	2230	0.1	0.1
7.5	4	9400	3370	1.3	0.6	10300	2220	0.58	0.09	11300	2440	0.1	0.1
10	4	7100	3230	1.4	0.7	7800	2130	0.67	0.1	8500	2330	0.12	0.12
7.5	6	9400	5050	1.3	0.6	10300	3330	0.58	0.09	11300	2440	0.1	0.1
10	6	7100	4840	1.4	0.7	7800	3200	0.67	0.1	8500	2330	0.12	0.12

Material <i>Matière</i>		Stahl <i>Acier</i>											
		HRC 25 – 34											
		Schruppen <i>Ébauche</i>				Schlichten mit RE2 <i>Finition avec RE2</i>				Schlichten mit RE1 <i>Finition avec RE1</i>			
DC	ZEFP	n	Vf	ap	ae	n	Vf	ap	ae	n	Vf	ap	ae
mm		min ⁻¹	mm/min	mm	mm	min ⁻¹	mm/min	mm	mm	min ⁻¹	mm/min	mm	mm
3	4	21300	2300	0.57	0.2	23200	1500	0.33	0.055	25400	1650	0.07	0.07
5	4	12800	2530	0.86	0.4	13900	1650	0.47	0.07	15200	1810	0.1	0.1
7.5	4	8500	2760	1.24	0.6	9300	1800	0.58	0.09	10200	1970	0.1	0.1
10	4	6400	2640	1.33	0.7	7000	1730	0.67	0.1	7600	1890	0.12	0.12
7.5	6	8500	4130	1.24	0.6	9300	2700	0.58	0.09	10200	1970	0.1	0.1
10	6	6400	3960	1.33	0.7	7000	2590	0.67	0.1	7600	1890	0.12	0.12

Material <i>Matière</i>		Vorgehärteter Stahl <i>Acier pré-trempé</i>											
		HRC 35 – 45											
		Schruppen <i>Ébauche</i>				Schlichten mit RE2 <i>Finition avec RE2</i>				Schlichten mit RE1 <i>Finition avec RE1</i>			
DC	ZEFP	n	Vf	ap	ae	n	Vf	ap	ae	n	Vf	ap	ae
mm		min ⁻¹	mm/min	mm	mm	min ⁻¹	mm/min	mm	mm	min ⁻¹	mm/min	mm	mm
3	4	19700	1910	0.54	0.2	20900	1220	0.33	0.055	22800	1330	0.07	0.07
5	4	11800	2100	0.81	0.4	12500	1340	0.47	0.07	13700	1470	0.1	0.1
7.5	4	7900	2300	1.17	0.6	8400	1460	0.58	0.09	9200	1600	0.1	0.1
10	4	5900	2200	1.26	0.7	6300	1400	0.67	0.1	6900	1530	0.12	0.12
7.5	6	7900	3440	1.17	0.6	8400	2190	0.58	0.09	9200	1600	0.1	0.1
10	6	5900	3300	1.26	0.7	6300	2100	0.67	0.1	6900	1530	0.12	0.12

SCHNITTDATEN *Données de coupe*

Material <i>Matière</i>		Gehärteter Stahl <i>Acier trempé</i>											
		HRC 46 – 55											
		Schruppen <i>Ébauche</i>				Schichten mit RE2 <i>Finition avec RE2</i>				Schichten mit RE1 <i>Finition avec RE1</i>			
DC	ZEFP	n	Vf	ap	ae	n	Vf	ap	ae	n	Vf	ap	ae
mm		min ⁻¹	mm/min	mm	mm	min ⁻¹	mm/min	mm	mm	min ⁻¹	mm/min	mm	mm
3	4	17600	1540	0.51	0.16	18800	990	0.33	0.04	20600	1080	0.07	0.06
5	4	10600	1690	0.77	0.32	11300	1090	0.47	0.06	12400	1190	0.1	0.08
7.5	4	7100	1840	1.11	0.48	7500	1180	0.58	0.07	8300	1300	0.1	0.08
10	4	5300	1770	1.2	0.56	5700	1140	0.67	0.08	6200	1240	0.12	0.1
7.5	6	7100	2760	1.11	0.48	7500	1770	0.58	0.07	8300	1300	0.1	0.08
10	6	5300	2650	1.2	0.56	5700	1700	0.67	0.08	6200	1240	0.12	0.1

Material <i>Matière</i>		Gehärteter Stahl <i>Acier trempé</i>											
		HRC 56 – 64											
		Schruppen <i>Ébauche</i>				Schichten mit RE2 <i>Finition avec RE2</i>				Schichten mit RE1 <i>Finition avec RE1</i>			
DC	ZEFP	n	Vf	ap	ae	n	Vf	ap	ae	n	Vf	ap	ae
mm		min ⁻¹	mm/min	mm	mm	min ⁻¹	mm/min	mm	mm	min ⁻¹	mm/min	mm	mm
3	4	14400	1130	0.46	0.14	16900	800	0.33	0.04	18500	880	0.07	0.05
5	4	8600	1250	0.69	0.28	10200	880	0.47	0.05	11100	960	0.1	0.08
7.5	4	5800	1360	1	0.42	6800	960	0.58	0.06	7400	1050	0.1	0.08
10	4	4300	1300	1.08	0.49	5100	920	0.67	0.07	5600	1010	0.12	0.1
7.5	6	5800	2040	1	0.42	6800	1440	0.58	0.06	7400	1050	0.1	0.08
10	6	4300	1950	1.08	0.49	5100	1380	0.67	0.07	5600	1010	0.12	0.1

Material <i>Matière</i>		Gehärteter Stahl <i>Acier trempé</i>											
		HRC 65 – 70											
		Schruppen <i>Ébauche</i>				Schichten mit RE2 <i>Finition avec RE2</i>				Schichten mit RE1 <i>Finition avec RE1</i>			
DC	ZEFP	n	Vf	ap	ae	n	Vf	ap	ae	n	Vf	ap	ae
mm		min ⁻¹	mm/min	mm	mm	min ⁻¹	mm/min	mm	mm	min ⁻¹	mm/min	mm	mm
3	4	11700	830	0.42	0.12	12700	540	0.33	0.03	13900	590	0.07	0.04
5	4	7100	920	0.63	0.24	7600	600	0.47	0.04	8400	650	0.1	0.06
7.5	4	4700	1000	0.9	0.36	5100	650	0.58	0.05	5600	710	0.1	0.06
10	4	3600	960	0.97	0.42	3800	620	0.67	0.06	4200	680	0.12	0.07
7.5	6	4700	1490	0.9	0.36	5100	970	0.58	0.05	5600	710	0.1	0.06
10	6	3600	1430	0.97	0.42	3800	930	0.67	0.06	4200	680	0.12	0.07

GSXRM 4000

VHM-Schruppfräser
Fraise d'ébauche en carbure

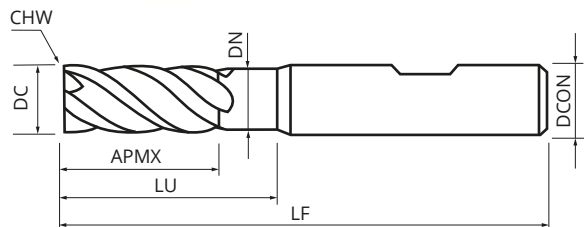

- Schrappfräser speziell geeignet für rostfreien Stahl, Superlegierungen und Stahl

Fraise d'ébauche spécialement adaptée pour l'acier inoxydable, les superalliages et l'acier

ABMESSUNGEN *Dimensions*

Artikelnummer <i>Référence</i>	DC	APMX	LU	LF	DCON	DN	CHW	ZEPF
(WGR. 7688)	mm	mm	mm	mm	mm	mm	mm	
GSXRM 4040	4	11	17	57	6	3.8	0.15	4
GSXRM 4050	5	13	19	57	6	4.8	0.15	4
GSXRM 4060	6	13	21	57	6	5.8	0.2	4
GSXRM 4080	8	19	27	63	8	7.6	0.2	4
GSXRM 4100	10	22	32	72	10	9.5	0.3	4
GSXRM 4120	12	26	38	83	12	11.5	0.35	4
GSXRM 4160	16	32	44	92	16	15.5	0.4	4
GSXRM 4200	20	38	54	104	20	19.5	0.5	4

SCHNITTDATEN *Données de coupe*

Material <i>Matière</i>	Stahl / legierter Stahl <i>Acier / Acier allié</i>								Rostfreier Stahl <i>Acier inoxydable</i>							
	< 850 N/mm ²								ferritisch und martensitisch <i>Ferritique et martensitique</i>							
	100% ae				50% ae				100% ae				50% ae			
DC mm	n min ⁻¹	Vf mm/min	ap mm	ae mm	n min ⁻¹	Vf mm/min	ap mm	ae mm	n min ⁻¹	Vf mm/min	ap mm	ae mm	n min ⁻¹	Vf mm/min	ap mm	ae mm
4	7570	727	4	4	8760	1227	8	2	7570	606	4	4	8760	982	8	2
5	6060	728	5	5	7010	1206	10	2.5	6060	606	5	5	7010	982	10	2.5
6	5050	728	6	6	5840	1192	12	3	5050	606	6	6	5840	982	12	3
8	3790	728	8	8	4380	1192	16	4	3790	607	8	8	4380	982	16	4
10	3030	728	10	10	3510	1194	20	5	3030	606	10	10	3510	997	20	5
12	2530	729	12	12	2920	1168	24	6	2530	608	12	12	2920	993	24	6
16	1900	730	16	16	2190	1227	30	8	1900	608	16	16	2190	990	30	8
20	1520	730	20	20	1760	1197	36	10	1520	608	20	20	1760	1007	36	10

Material <i>Matière</i>	Rostfreier Stahl <i>Acier inoxydable</i>								Superlegierung <i>Superalliage</i>							
	austenitisch								Titan <i>Titane</i>							
	50% ae				25% ae				50% ae				25% ae			
DC mm	n min ⁻¹	Vf mm/min	ap mm	ae mm	n min ⁻¹	Vf mm/min	ap mm	ae mm	n min ⁻¹	Vf mm/min	ap mm	ae mm	n min ⁻¹	Vf mm/min	ap mm	ae mm
4	5580	358	4	2	6770	596	8	1	4380	281	3	2	5580	492	4	1
5	4460	357	5	2.5	5420	629	10	1.2	3510	281	4	2.5	4460	518	5	1.2
6	3720	358	6	3	4520	615	12	1.5	2920	281	4.5	3	3720	506	6	1.5
8	2790	358	8	4	3390	611	16	2	2190	281	6	4	2790	503	8	2
10	2230	357	10	5	2710	608	20	2.5	1760	282	7.5	5	2230	500	10	2.5
12	1860	358	12	6	2260	602	24	3	1460	281	9	6	1860	495	12	3
16	1400	359	16	8	1700	612	30	4	1100	282	12	8	1400	504	16	4
20	1120	359	20	10	1360	626	36	5	880	282	15	10	1120	516	20	5



**NEUE*
MODELLE**
nouveaux
modèles

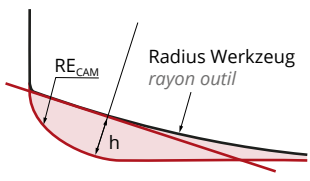
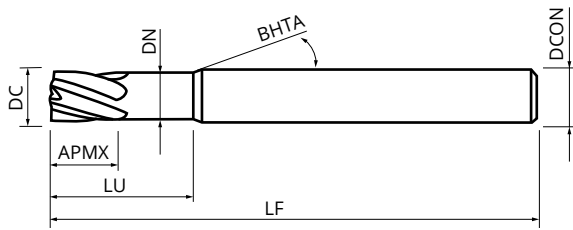

- Besonders gut geeignet in Stahl bis HRC 66
Pour l'utilisation dans l'acier jusqu'à 66 HRC
- Spezielle Stirngeometrie für Highfeed Operationen
Géométrie de face spéciale pour les opérations à grande avance
- Radiustoleranz 0.01mm *Tolérance de rayon 0.01mm*

ABMESSUNGEN *Dimensions*

Artikelnummer <i>Référence</i> (WGR. 7686)	DC	RECAM	h	APMX	LU	BHTA	LF	DCON	DN	ZEPF
	mm	mm	mm	mm	mm	mm	mm	mm	mm	
RHCSN 4010R0088	1	0.088	0.017	1	3	16	58	6	0.9	4
* RHCSN 4015R0132	1.5	0.132	0.026	1.5	4.5	16	51	6	1.4	4
RHCSN 4020R0176	2	0.176	0.034	2	6	16	58	6	1.8	4
* RHCSN 4025R0220	2.5	0.220	0.043	2.5	7.5	16	51	6	2.3	4
RHCSN 4030R0264	3	0.264	0.051	3	9	16	58	6	2.8	4
RHCSN 6040R0352	4	0.352	0.068	4	12	16	58	6	3.8	6
RHCSN 6050R044	5	0.440	0.085	5	15	16	58	6	4.7	6
RHCSN 6060R0528	6	0.528	0.102	6	18	-	58	6	5.7	6
RHCSN 6080R0704	8	0.704	0.136	8	24	-	80	8	7.6	6
RHCSN 6100R088	10	0.880	0.170	10	30	-	80	10	9.5	6
RHCSN 6120R1056	12	1.056	0.204	12	36	-	100	12	11.5	6

SCHNITTDATEN *Données de coupe*

Material Matière	Legierter Stahl <i>Acier allié</i>				Hochlegierter Stahl <i>Acier fortement allié</i>				Werkzeugstahl <i>Acier à outil</i>			
	1.2311 / 1.2312 / 1.2714 / 1.2738				1.2080 / 1.2379				1.2343 / 1.2344 / 1.2365 / 1.2367			
DC mm	n min ⁻¹	Vf mm/min	ap mm	ae mm	n min ⁻¹	Vf mm/min	ap mm	ae mm	n min ⁻¹	Vf mm/min	ap mm	ae mm
1	57200	10290	0.042	0.75	50900	8550	0.04	0.75	44500	7120	0.037	0.7
1.5	38200	10240	0.063	1.12	34000	8600	0.06	1.12	29500	7100	0.06	1.05
2	28600	10290	0.084	1.5	25400	8530	0.08	1.5	22200	7100	0.074	1.4
2.5	22900	10270	0.105	1.85	20400	8600	0.1	1.85	17700	7100	0.09	1.75
3	19000	10260	0.126	2.25	16900	8510	0.12	2.25	14800	7100	0.111	2.1
4	14300	15440	0.168	3	12700	12800	0.16	3	11100	10650	0.148	2.8
5	11400	15390	0.21	3.75	10100	12720	0.2	3.75	8900	10680	0.185	3.5
6	9500	15390	0.252	4.5	8400	12700	0.24	4.5	7400	10650	0.222	4.2
8	7100	15330	0.336	6	6300	12700	0.32	6	5500	10560	0.296	5.6
10	5700	15390	0.42	7.5	5000	12600	0.4	7.5	4400	10560	0.37	7
12	4700	15220	0.504	9	4200	12700	0.48	9	3700	10650	0.444	8.4

Material Matière	Gehärteter Stahl <i>Acier trempé</i>											
	HRC 48 – 51				HRC 52 – 55				HRC 56 – 59			
DC mm	n min ⁻¹	Vf mm/min	ap mm	ae mm	n min ⁻¹	Vf mm/min	ap mm	ae mm	n min ⁻¹	Vf mm/min	ap mm	ae mm
1	38100	6090	0.037	0.7	31800	5080	0.037	0.7	27000	3240	0.03	0.7
1.5	25500	6100	0.06	1.05	21200	5100	0.06	1.05	18000	3200	0.05	1.05
2	19000	6080	0.074	1.4	15900	5080	0.074	1.4	13500	3240	0.06	1.4
2.5	15300	6100	0.09	1.75	12700	5100	0.09	1.75	10800	3200	0.08	1.75
3	12700	6090	0.111	2.1	10600	5080	0.111	2.1	9000	3240	0.09	2.1
4	9500	9120	0.148	2.8	7900	7580	0.148	2.8	6700	4820	0.12	2.8
5	7600	9120	0.185	3.5	6300	7560	0.185	3.5	5400	4860	0.15	3.5
6	6300	9070	0.222	4.2	5300	7310	0.222	4.2	4500	4860	0.18	4.2
8	4700	9020	0.296	5.6	3900	7250	0.296	5.6	3300	4750	0.24	5.6
10	3800	9120	0.37	7	3100	7250	0.37	7	2700	4860	0.3	7
12	3100	8920	0.444	8.4	2600	7330	0.444	8.4	2200	4750	0.36	8.4

Material Matière	Gehärteter Stahl <i>Acier trempé</i>							
	HRC 60 – 62				HRC 63 – 66			
DC mm	n min ⁻¹	Vf mm/min	ap mm	ae mm	n min ⁻¹	Vf mm/min	ap mm	ae mm
1	22200	2220	0.025	0.65	19000	1520	0.02	0.6
1.5	14800	2200	0.04	0.98	12700	1500	0.03	0.9
2	11100	2220	0.05	1.3	9500	1520	0.04	1.2
2.5	8900	2200	0.06	1.63	7600	1500	0.05	1.5
3	7400	2220	0.075	1.95	6300	1510	0.06	1.8
4	5500	3300	0.1	2.6	4700	2250	0.08	2.4
5	4400	3300	0.125	3.25	3800	2280	0.1	3
6	3700	3330	0.15	3.9	3100	2230	0.12	3.6
8	2700	3240	0.2	5.2	2300	2200	0.16	4.8
10	2200	3300	0.25	6.5	1900	2280	0.2	6
12	1800	3240	0.3	7.8	1500	2160	0.24	7.2

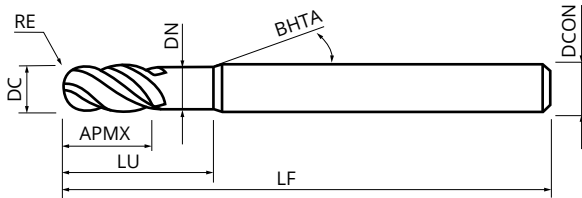

- Zum Schruppen und Vorschlichten in vorgehärtetem und gehärtetem Stahl von 30 bis 70 HRC
Pour l'ébauche et la pré finition dans les aciers prétrempés et trempés de 30 à 70 HRC

DC	RE	Toleranzen Tolérances	
1 - 3	R0.5 - R1.5	0/-0.01 DC-TOL	±0.005 RE
4 - 6	R2 - R3	0/-0.014 DC-TOL	±0.007 RE
8 - 12	R4 - R6	0/-0.02 DC-TOL	±0.01 RE

ABMESSUNGEN *Dimensions*

Artikelnummer <i>Référence</i> (WGR. 7778)	DC	RE	APMX	LU	DN	LF	DCON	BHTA	ZEPF
	mm	mm	mm	mm	mm	mm	mm	°	
EFLB 4010-030-4	1	0.5	1.5	3	0.95	50	4	15	4
EFLB 4010-030-6	1	0.5	1.5	3	0.95	50	6	15	4
EFLB 4015-045-4	1.5	0.75	2.5	4.5	1.43	50	4	15	4
EFLB 4015-045-6	1.5	0.75	2.5	4.5	1.43	50	6	15	4
EFLB 4020-060-4	2	1	3	6	1.9	50	4	15	4
EFLB 4020-060-6	2	1	3	6	1.9	50	6	15	4
EFLB 4025-075-4	2.5	1.25	4	7.5	2.38	50	4	15	4
EFLB 4025-075-6	2.5	1.25	4	7.5	2.38	50	6	15	4
EFLB 4030-090-4	3	1.5	4.5	9	2.9	70	4	15	4
EFLB 4030-090-6	3	1.5	4.5	9	2.9	70	6	15	4
EFLB 4040-120-4	4	2	6	12	3.9	70	4	-	4
EFLB 4040-120-6	4	2	6	12	3.9	70	6	15	4
EFLB 4050-150-6	5	2.5	7.5	15	4.7	80	6	15	4
EFLB 4060-180-6	6	3	9	18	5.7	90	6	-	4
EFLB 4060-180-6S	6	3	9	18	5.7	60	6	-	4
EFLB 4080-240-8	8	4	12	24	7.6	100	8	-	4
EFLB 4080-240-8S	8	4	12	24	7.6	70	8	-	4
EFLB 4100-300-10	10	5	15	30	9.5	100	10	-	4
EFLB 4100-300-10S	10	5	15	30	9.5	70	10	-	4
EFLB 4120-360-12	12	6	18	36	11.5	110	12	-	4
EFLB 4120-360-12S	12	6	18	36	11.5	84	12	-	4

SCHNITTDATEN – SCHRUPPEN *Données de coupe – ébauche*

Material Matière		Vorgehärteter Stahl <i>Acier pré-trempé</i> (Vor-)gehärteter Stahl <i>Acier (pré-) trempé</i>				Gehärteter Stahl <i>Acier trempé</i>							
		30 – 41 HRC				42 – 51 HRC				52 – 57 HRC			
DC	RE	n	Vf	ap	ae	n	Vf	ap	ae	n	Vf	ap	ae
mm	mm	min ⁻¹	mm/min	mm	mm	min ⁻¹	mm/min	mm	mm	min ⁻¹	mm/min	mm	mm
1	R0.5	40000	5940	0.13	0.39	40000	4160	0.09	0.33	40000	3200	0.08	0.30
1.5	R0.75	40000	7430	0.19	0.66	40000	5200	0.14	0.55	38200	3820	0.12	0.50
2	R1	39000	10150	0.24	0.79	31800	5790	0.17	0.66	28600	4010	0.15	0.60
2.5	R1.25	31200	9280	0.32	1.06	25400	5290	0.23	0.88	22900	3660	0.20	0.80
3	R1.5	26000	9660	0.41	1.26	21200	5520	0.29	1.04	19100	3820	0.25	0.95
4	R2	19500	9420	0.49	1.59	15900	5380	0.35	1.32	14300	3720	0.30	1.20
5	R2.5	15600	9860	0.65	2.12	12700	5630	0.47	1.76	11400	3890	0.40	1.60
6	R3	13000	9660	0.77	2.52	10600	5520	0.55	2.09	9500	3820	0.47	1.90
8	R4	9700	10150	1.06	3.32	7900	5790	0.76	2.75	7100	4010	0.65	2.50
10	R5	7800	10150	1.31	4.12	6300	5790	0.94	3.41	5700	4010	0.80	3.10
12	R6	6500	9660	1.56	4.65	5300	5520	1.12	3.85	4700	3820	0.95	3.50

Material Matière		Gehärteter Stahl <i>Acier trempé</i>											
		58 – 62 HRC				63 – 66 HRC				67 – 70 HRC			
DC	RE	n	Vf	ap	ae	n	Vf	ap	ae	n	Vf	ap	ae
mm	mm	min ⁻¹	mm/min	mm	mm	min ⁻¹	mm/min	mm	mm	min ⁻¹	mm/min	mm	mm
1	R0.5	40000	2240	0.06	0.24	38200	1490	0.05	0.20	31800	870	0.04	0.16
1.5	R0.75	31800	2220	0.09	0.41	25400	1240	0.08	0.33	21200	720	0.06	0.27
2	R1	23800	2340	0.12	0.49	19100	1310	0.10	0.40	15900	760	0.07	0.33
2.5	R1.25	19100	2140	0.16	0.65	15200	1190	0.13	0.53	12700	690	0.10	0.44
3	R1.5	15900	2220	0.20	0.77	12700	1240	0.16	0.63	10600	720	0.12	0.52
4	R2	11900	2170	0.24	0.98	9500	1210	0.20	0.80	7900	710	0.15	0.66
5	R2.5	9500	2270	0.32	1.31	7600	1270	0.26	1.07	6300	740	0.20	0.88
6	R3	7900	2220	0.38	1.55	6300	1240	0.31	1.27	5300	720	0.23	1.04
8	R4	5900	2340	0.53	2.05	4700	1310	0.43	1.68	3900	760	0.32	1.37
10	R5	4700	2340	0.65	2.54	3800	1310	0.53	2.08	3100	760	0.40	1.70
12	R6	3900	2220	0.77	2.87	3100	1240	0.63	2.35	2600	720	0.47	1.92

SCHNITTDATEN – SCHLICHTEN *Données de coupe – finition*

Material Matière		Vorgehärteter Stahl <i>Acier pré-trempé</i> (Vor-)gehärteter Stahl <i>Acier (pré-) trempé</i>				Gehärteter Stahl <i>Acier trempé</i>							
		30 – 41 HRC				42 – 51 HRC				52 – 57 HRC			
DC	RE	n	Vf	ap	ae	n	Vf	ap	ae	n	Vf	ap	ae
mm	mm	min ⁻¹	mm/min	mm	mm	min ⁻¹	mm/min	mm	mm	min ⁻¹	mm/min	mm	mm
1	R0.5	40000	3520	0.05	0.04	40000	3360	0.05	0.04	40000	3200	0.05	0.04
1.5	R0.75	40000	4400	0.06	0.06	40000	4200	0.06	0.06	38200	3820	0.06	0.06
2	R1	39000	6000	0.07	0.08	39800	5850	0.07	0.08	28600	4010	0.07	0.08
2.5	R1.25	36900	6500	0.08	0.10	31800	5350	0.08	0.10	22900	3660	0.08	0.10
3	R1.5	30700	6770	0.09	0.12	26500	5570	0.09	0.12	19100	3820	0.09	0.12
4	R2	23000	6600	0.10	0.14	19900	5430	0.10	0.14	14300	3720	0.10	0.14
5	R2.5	18400	6900	0.12	0.16	15900	5680	0.12	0.16	11400	3890	0.12	0.16
6	R3	15300	6770	0.13	0.18	13200	5570	0.13	0.18	9500	3430	0.13	0.18
8	R4	11500	7110	0.15	0.20	9900	5850	0.15	0.20	7100	2860	0.15	0.20
10	R5	9200	7110	0.16	0.22	7900	5850	0.16	0.22	5700	2750	0.16	0.22
12	R6	7600	6770	0.18	0.25	6600	5570	0.18	0.25	4700	2670	0.18	0.25

Material Matière		Gehärteter Stahl <i>Acier trempé</i>											
		58 – 62 HRC				63 – 66 HRC				67 – 70 HRC			
DC	RE	n	Vf	ap	ae	n	Vf	ap	ae	n	Vf	ap	ae
mm	mm	min ⁻¹	mm/min	mm	mm	min ⁻¹	mm/min	mm	mm	min ⁻¹	mm/min	mm	mm
1	R0.5	40000	2240	0.05	0.04	40000	1790	0.04	0.03	39800	1420	0.03	0.02
1.5	R0.75	31800	2220	0.06	0.06	28600	1600	0.05	0.04	26500	1180	0.03	0.04
2	R1	23800	2340	0.07	0.08	21400	1680	0.06	0.06	19900	1240	0.04	0.05
2.5	R1.25	19100	2140	0.08	0.10	17100	1540	0.06	0.08	15900	1140	0.04	0.06
3	R1.5	15900	2220	0.09	0.12	14300	1600	0.07	0.09	13200	1180	0.05	0.08
4	R2	11900	2170	0.10	0.14	10700	1560	0.08	0.11	9900	1150	0.06	0.09
5	R2.5	9500	2270	0.12	0.16	8500	1630	0.09	0.13	7900	1210	0.07	0.10
6	R3	7900	2220	0.13	0.18	7100	1600	0.10	0.14	6600	1180	0.07	0.12
8	R4	5900	2340	0.15	0.20	5300	1680	0.12	0.16	4900	1240	0.09	0.13
10	R5	4700	2340	0.16	0.22	4200	1680	0.13	0.18	3900	1240	0.10	0.14
12	R6	3900	1780	0.18	0.25	3500	1280	0.14	0.20	3300	950	0.11	0.16

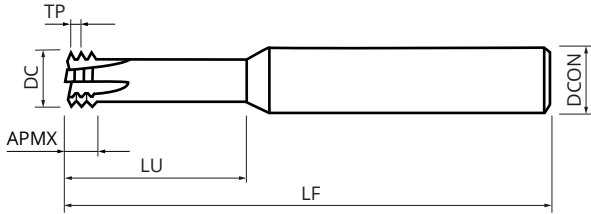

- Zur Anwendung in Stahl bis HRC 63, rostfreiem Stahl, Guss und Superlegierungen *Pour l'utilisation dans l'acier jusqu'à 63 HRC, l'acier inoxydable, la fonte et les superalliages*
- Zirkularbohrgewindefräsen bis 2.5 x D Gewindetiefe *Fraise à percer et fileter jusqu'à 2.5 x D de profondeur du filetage*
- LINKSSCHNEIDEND *COUPE À GAUCHE*

ABMESSUNGEN *Dimensions*

Artikelnummer <i>Référence</i> (WGR. 7620)	FTDZ	TP	DC	APMX	LU	LF	DCON	ZEFP
		mm	mm	mm	mm	mm	mm	
CDTMLM2	M2 - M2.3	0.4	1.46	1.2	5.8	58	6	4
CDTMLM2.5	M2.5 - M2.6	0.45	1.9	1.35	7.2	58	6	4
CDTMLM3	M3 - MF4	0.5	2.33	1.5	8.25	58	6	4
CDTMLM4	M4	0.7	3.1	2.1	11.2	58	6	4
CDTMLM5	M5	0.8	3.9	2.4	13.7	58	6	4
CDTMLM6	M6 - MF8	1	4.7	3	17.6	58	6	4
CDTMLM8	M8 - MF10	1.25	6.4	3.75	22	62	8	4
CDTMLM10	M10 - MF12	1.5	8.1	4.5	27.5	76	10	4
CDTMLM12	M12	1.75	9.8	5.25	32.8	76	10	4
CDTMLM14	M14 - M16	2	11.5	6	38.2	88	12	4
CDTMLM16	M16 - MF18	2	13.4	6	43.2	92	14	4
CDTMLMF8X075	MF8	0.75	6.8	2.25	22	62	8	4
CDTMLMF10X100	MF10	1	8.5	3	27.5	76	10	4

Artikelnummer <i>Référence</i> (WGR. 7620)	FTDZ	TP	DC	APMX	LU	LF	DCON	ZEFP
		mm	mm	mm	mm	mm	mm	
CDTMLG1/8	G1/8"	28	8.1	2.72	27	76	10	4
CDTMLG1/4	G1/4"	19	11	4.01	36	88	12	4
CDTMLG3/8	G3/8"	19	14.4	4.01	44	96	16	4

SCHNITTDATEN *Données de coupe*

					Durchmesserbereich Dc - fz <i>Plage de diamètres Dc - fz</i>								
Material <i>Matière</i>	Werkstoffnr. <i>N° de matières</i>	Beispiel <i>Exemple</i>	Festigkeit <i>Résistance</i>	VC	<2.0	<3.0	<4.0	<5.0	<6.0	<8.0	<10.0	<12.0	<16.0
			N/mm ²		m/min	mm/Z	mm/Z	mm/Z	mm/Z	mm/Z	mm/Z	mm/Z	mm/Z
Allgemeiner Baustahl <i>Acier de construction</i>	1.0037	St37-2	≤ 500	85	0.013	0.015	0.02	0.024	0.032	0.039	0.047	0.052	0.056
	1.006	St60-2	≤ 850	70	0.012	0.014	0.019	0.022	0.03	0.036	0.043	0.048	0.052
Automatenstahl <i>Acier de décolletage</i>	1.0718	9SMnPb28	≤ 850	75	0.012	0.014	0.019	0.022	0.03	0.036	0.043	0.048	0.052
	1.0728	60S20	≤ 1000	65	0.011	0.013	0.018	0.02	0.028	0.033	0.039	0.044	0.048
Unlegierter Vergütungsstahl <i>Acier revenu non allié</i>	1.0501	C35	≤ 700	85	0.013	0.015	0.02	0.024	0.032	0.039	0.047	0.052	0.056
	1.1191	Ck45	≤ 850	75	0.012	0.014	0.019	0.022	0.03	0.036	0.043	0.048	0.052
	1.1221	Ck60	≤ 1000	65	0.011	0.013	0.018	0.02	0.028	0.033	0.039	0.044	0.048
Legierter Vergütungsstahl <i>Acier revenu allié</i>	1.1167	36Mn5	≤ 1000	70	0.011	0.013	0.018	0.02	0.028	0.033	0.039	0.044	0.048
	1.6582	34CrNiMo6	≤ 1200	60	0.01	0.012	0.017	0.019	0.026	0.031	0.036	0.041	0.045
Unlegierter Einsatzstahl <i>Acier de cementation non allié</i>	1.1141	Ck15	≤ 750	85	0.013	0.015	0.02	0.024	0.032	0.039	0.047	0.052	0.056
Leg. Einsatzstahl <i>Acier de cementation allié</i>	1.7131	16MnCr5	≤ 1000	70	0.011	0.013	0.018	0.02	0.028	0.033	0.039	0.044	0.048
	1.7147	20MnCr5	≤ 1200	60	0.01	0.012	0.017	0.019	0.026	0.031	0.036	0.041	0.045
Nitrierstahl <i>Acier de nituration</i>	1.8506	34CrAlS5	≤ 1000	70	0.011	0.013	0.018	0.02	0.028	0.033	0.039	0.044	0.048
	1.8519	31CrMoV9	≤ 1200	60	0.01	0.012	0.017	0.019	0.026	0.031	0.036	0.041	0.045
Werkzeugstahl <i>Acier à outil</i>	1.2067	100Cr6	≤ 850	70	0.012	0.014	0.019	0.022	0.03	0.036	0.043	0.048	0.052
	1.2316	X36CrMo17	≤ 1100	65	0.011	0.013	0.018	0.02	0.028	0.033	0.039	0.044	0.048
	1.2436	X210CrW12	≤ 1800	50	0.01	0.012	0.017	0.019	0.026	0.031	0.036	0.041	0.045
Rostfreier Stahl <i>Acier inoxydable</i>	1.4301	X8CrNiS18 9 ¹⁾	≤ 700	45	0.012	0.014	0.019	0.022	0.03	0.036	0.043	0.048	0.052
	1.4021	X5CrNi18 10 ²⁾	≤ 700	40	0.011	0.013	0.018	0.02	0.028	0.033	0.039	0.044	0.048
	-	X20Cr5 13 ³⁾	≤ 1100	35	0.01	0.012	0.017	0.019	0.026	0.031	0.036	0.041	0.045
Gusseisen <i>Fonte</i>	0.6025	GG-25	≤ 180 HwB	85	0.017	0.019	0.024	0.03	0.038	0.045	0.055	0.06	0.064
	0.706	GGG-60	≤ 260 HB	80	0.015	0.017	0.022	0.026	0.034	0.04	0.048	0.053	0.057
	0.8165	GTS-65	-	75	0.011	0.013	0.018	0.02	0.028	0.033	0.039	0.044	0.048
Titanlegierung <i>Alliages de titane</i>	3.7114	TiAl5Sn2,5	≤ 850	45	0.011	0.013	0.018	0.02	0.028	0.033	0.039	0.044	0.048
	3.7164	TiAl6V4	≤ 1200	35	0.01	0.012	0.017	0.019	0.026	0.031	0.036	0.041	0.045
Gehärteter Stahl <i>Acier trempé</i>	-	-	≤ 44 HRC	55	0.009	0.013	0.016	0.02	0.027	0.033	0.04	0.044	0.048
	-	-	≤ 54 HRC	50	0.008	0.012	0.015	0.018	0.025	0.03	0.036	0.04	0.044
	-	-	≤ 63 HRC	40	0.007	0.011	0.014	0.017	0.023	0.028	0.033	0.037	0.041

- 1) geschwefelt *sulfuré*
 2) austenitisch *austénitique*
 3) martensitisch *martensitique*

Der angegebene Vorschub bezieht sich auf die Fräser-Aussenbahn:

$$V_f \text{ Mittelpunkt} = f_z \times z \times n \times (D - DC) / D$$

L'avance préconisée fait référence à la vitesse périphérique:

$$V_f \text{ centre de l'outil} = f_z \times z \times n \times (D - DC) / D$$



M

371

DIN

376

DIN

B

FORM

6H

ISO2

SST

COAT

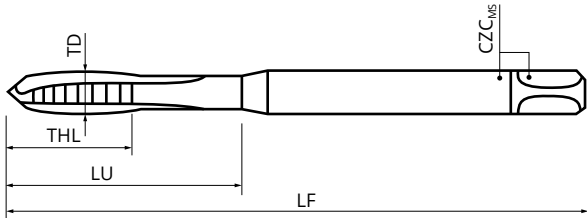

P

M

K

N

- Zur universellen Anwendung in Stahl, rostfreiem Stahl, Guss, Kupfer und Aluminium *Pour l'utilisation universelle dans l'acier, l'acier inoxydable, la fonte, le cuivre et l'aluminium*
- HSSE-PM Durchgangsgewindebohrer bis 3 x D *Taraud pour trou traversant HSSE PM jusqu'à 3 x D*

ABMESSUNGEN *Dimensions*

Artikelnummer <i>Référence</i> (WGR. 7610)	TDZ	TP	THL	LU	LF	CZCMS	DIN
	mm	mm	mm	mm	mm	mm	
TTM2	M2	0.4	9	-	45	2.8 x 2.1	DIN 371
TTM2.5	M2.5	0.45	9	14	50	2.8 x 2.1	DIN 371
TTM3	M3	0.5	10	18	56	3.5 x 2.7	DIN 371
TTM4	M4	0.7	12	21	63	4.5 x 3.4	DIN 371
TTM5	M5	0.8	14	25	70	6 x 4.9	DIN 371
TTM6	M6	1	16	30	80	6 x 4.9	DIN 371
TTM8	M8	1.25	18	35	90	8 x 6.2	DIN 371
TTM10	M10	1.5	20	39	100	10 x 8	DIN 371
TTM12	M12	1.75	24	-	110	9 x 7	DIN 376
TTM16	M16	2	27	-	110	12 x 9	DIN 376
TTM20	M20	2.5	32	-	140	16 x 12	DIN 376

SCHNITTDATEN *Données de coupe*

Material <i>Matière</i>	Werkstoffbeispiel <i>Exemple de matière</i>	N/mm²	HB	Vc m/min
Unlegierter Baustahl / Weicheisen <i>Acier de construction non-allié / Fer doux</i>	1.0330	100 – 450	90 – 120	20 – 30
Baustahl / Einsatzstahl <i>Acier de construction / Acier de cémentation</i>	1.0038	300 – 700	80 – 150	20 – 30
Bau- / Kohlenstoffstahl C < 0.45% <i>Acier de construction / Acier au carbone C < 0.45%</i>	1.0503	400 – 950	172 – 242	20 – 30
Kohlenstoffstahl C > 0.45% <i>Acier au carbone C > 0.45%</i>	1.7225	450 – 950	217 – 237	15 – 35
Legierter Stahl / Hochlegierter Stahl <i>Acier allié / Acier fortement allié</i>	1.2379	800 – 1250	235 – 370	10 – 20
Stahl ferritisch und martensitisch <i>Acier ferritique et martensitique</i>	1.4028	450 – 1200	260 – 425	6 – 12
Stahl austenitisch, aust.-ferritisch <i>Acier austénitique, austénitique-ferritique</i>	1.4571	400 – 950	150 – 215	6 – 12
Stahl austenitisch, aust.-ferritisch und ferritisch <i>Acier austénitique, austénitique-ferritique et ferritique</i>	1.4568	850 – 1250	250 – 455	3 – 8
Temperguss <i>Fonte malléable</i>	5.4101	300 – 700	100 – 200	15 – 25
Aluminium Si ≤ 0.5% <i>Aluminium ≤ 0.5% Si</i>	3.0205	100 – 700	30 – 200	15 – 35
Aluminium Si ≤ 6% <i>Aluminium ≤ 6% Si</i>	3.2151	150 – 700	45 – 200	15 – 40
Aluminium Si > 6% <i>Aluminium > 6% Si</i>	3.2381	150 – 900	45 – 265	15 – 40



M

371
DIN

376
DIN

C
FORM

6H
ISO2

SST
COAT

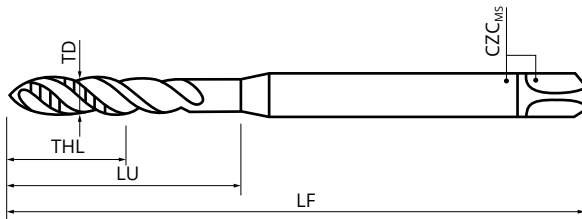

P

M

K

N

- Zur universellen Anwendung in Stahl, rostfreiem Stahl, Guss, Kupfer und Aluminium *Pour l'utilisation universelle dans l'acier, l'acier inoxydable, la fonte, le cuivre et l'aluminium*
- HSSE-PM Sacklochgewindebohrer bis 3xD
Taraud pour trou borgne HSSE PM jusqu'à 3 x D

ABMESSUNGEN *Dimensions*

Artikelnummer <i>Référence</i> (WGR. 7610)	TDZ	TP	THL	LU	LF	CZCMS	DIN
	mm	mm	mm	mm	mm	mm	
TBM3	M3	0.5	7	18	56	3.5 x 2.7	DIN 371
TBM4	M4	0.7	8	21	63	4.5 x 3.4	DIN 371
TBM5	M5	0.8	9	25	70	6 x 4.9	DIN 371
TBM6	M6	1	10	30	80	6 x 4.9	DIN 371
TBM8	M8	1.25	13	35	90	8 x 6.2	DIN 371
TBM10	M10	1.5	15	39	100	10 x 8	DIN 371
TBM12	M12	1.75	18	-	110	9 x 7	DIN 376
TBM16	M16	2	20	-	110	12 x 9	DIN 376
TBM20	M20	2.5	25	-	140	16 x 12	DIN 376

SCHNITTDATEN *Données de coupe*

Material <i>Matière</i>	Werkstoffbeispiel <i>Exemple de matière</i>	N/mm²	HB	Vc m/min
Unlegierter Baustahl / Weicheisen <i>Acier de construction non-allié / Fer doux</i>	1.0330	100 – 450	90 – 120	20 – 30
Baustahl / Einsatzstahl <i>Acier de construction / Acier de cémentation</i>	1.0038	300 – 700	80 – 150	20 – 30
Bau- / Kohlenstoffstahl C < 0.45% <i>Acier de construction / Acier au carbone C < 0.45%</i>	1.0503	400 – 950	172 – 242	20 – 30
Kohlenstoffstahl C > 0.45% <i>Acier au carbone C > 0.45%</i>	1.7225	450 – 950	217 – 237	15 – 35
Legierter Stahl / Hochlegierter Stahl <i>Acier allié / Acier fortement allié</i>	1.2379	800 – 1250	235 – 370	10 – 20
Stahl ferritisch und martensitisch <i>Acier ferritique et martensitique</i>	1.4028	450 – 1200	260 – 425	6 – 12
Stahl austenitisch, aust.-ferritisch <i>Acier austénitique, austénitique-ferritique</i>	1.4571	400 – 950	150 – 215	6 – 12
Stahl austenitisch, aust.-ferritisch und ferritisch <i>Acier austénitique, austénitique-ferritique et ferritique</i>	1.4568	850 – 1250	250 – 455	3 – 6
Temperguss <i>Fonte malléable</i>	5.4101	300 – 700	100 – 200	15 – 25
Aluminium Si ≤ 0.5% <i>Aluminium ≤ 0.5% Si</i>	3.0205	100 – 700	30 – 200	15 – 35
Aluminium Si ≤ 6% <i>Aluminium ≤ 6% Si</i>	3.2151	150 – 700	45 – 200	15 – 40
Aluminium Si > 6% <i>Aluminium > 6% Si</i>	3.2381	150 – 900	45 – 265	15 – 40

Technische Informationen – Gewinde

Informations techniques – filets

KERNLOCH DURCHMESSER

Diamètre de l'avant-trou

TDZ	TP	D1 min	D1 max	Bohrdurchmesser <i>Diamètre de perçage</i>
M2	0.4	1.583	1.658	1.6
M2.5	0.45	2.013	2.138	2.1
M3	0.5	2.459	2.599	2.5
M4	0.7	3.242	3.422	3.3
M5	0.8	4.134	4.334	4.2
M6	1	4.917	5.153	5
M8	1.25	6.647	6.912	6.8
M10	1.5	8.376	8.676	8.5
M12	1.75	10.106	10.441	10.2
M16	2	13.835	14.210	14
M20	2.5	17.294	17.774	17.5

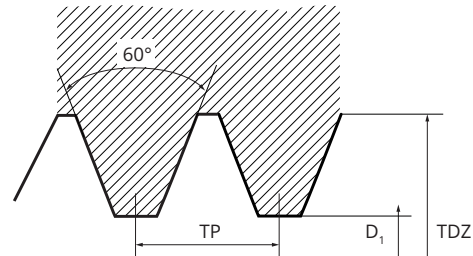

Metrisches ISO-Gewinde nach DIN 13 und DIN ISO 965-1
Filetage métrique ISO DIN 13 et DIN ISO 965-1

BERECHNUNGSFORMEL *Formule de calcul*

Parameter <i>Paramètre</i>	Formel <i>Formule</i>	Einheit <i>Unité</i>
Drehzahl <i>Vitesse de rotation</i>	$n = \frac{v_c \times 1000}{D_c \times \pi}$	[min ⁻¹]
Spezif. Schnittkraft <i>Force de coupe spécifique</i>	$k_c = k_{c1.1} \times \left[\frac{p^2}{2 \times Z \times L_f} \right]^{m_c}$	
Drehmoment Gewindebohrer <i>Couple du taraud</i>	$M_d = \frac{k_c \times D_N \times p^2}{8000} \times \left[\frac{L_c}{D_N} \right]^\delta \times \left[1.112 - \frac{Y}{100} \right]$	[Nm]
Leistung am Gewindebohrer <i>Effort de coupe</i>	$P = \frac{M_d \times n}{9500 \times \eta}$	[kW]

D1	Kernloch Durchmesser <i>Diamètre de l'avant-trou</i>	[mm]
TDZ	Gewindegröße <i>Taille du filet</i>	[mm]
TP	Gewindesteigung <i>Pas du filetage</i>	[mm]
n	Drehzahl <i>Vitesse de rotation</i>	[min ⁻¹]
v_c	Schnittgeschwindigkeit <i>Vitesse de coupe</i>	[m/min]
D_c	Schneidendurchmesser <i>Diamètre de coupe</i>	[mm]
D_N	Gewinde-Nennendurchmesser <i>Diamètre nominal du filetage</i>	[mm]
P	Gewindesteigung <i>Pas du filetage</i>	[mm]
z	Anzahl Nuten <i>Nombre de rainures</i>	
L_c	Gewindetiefe <i>Profondeur du filetage</i>	[mm]
L_f	Anschnittlänge <i>Longueur d'entrée</i>	[mm]
γ	Spanwinkel <i>Angle de coupe</i>	
δ	Korrekturfaktor (0.55 auf 0.25) <i>Facteur de correction (0.55 à 0.25)</i>	
k_c	Spezifische Schnittkraft <i>Force de coupe spécifique</i>	[N/mm ²]
F_c	Schnittkraft <i>Force de coupe</i>	[N]
M_d	Drehmoment <i>Couple</i>	[Nm]
P	Leistung am Gewindebohrer <i>Effort de coupe</i>	[kW]
η	Wirkungsgrad Maschine (< 1) <i>Rendement de la machine (< 1)</i>	

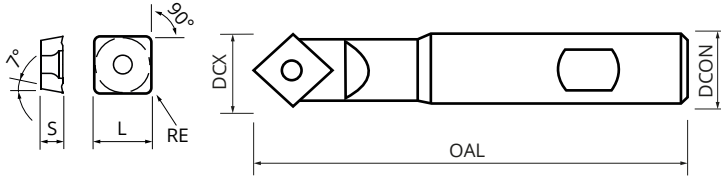

- Vielseitiges einsetzbares Multifunktionswerkzeug mit Wendeplatten *Outil polyvalent à plaquettes*
- Bearbeitungsmöglichkeiten: Anbohren, Entgraten und Gravieren *Usinages: pointage, ébavurage et gravage*
- Speziell ausgespitzte Wendeplatten für Anbohr-Operationen *Plaquettes spécialement pointues pour les opérations de pointage*

ABMESSUNGEN HALTER *Dimensions porte outil*

ArtNr. Référence	DCX	DCON	APMX	OAL	SIG	ZEFP
(WGR. 7888)	mm	mm	mm	mm	°	
SST-MTH-K-S16-90	13	16	6.5	100	90	1

ABMESSUNGEN WENDEPLATTE *Dimensions plaquette*

ArtNr. Référence	L	IC	S	RE
(WGR. 7888)	mm	mm	mm	mm
SOMT11T308 SSTP20	11.00	10.87	3.97	0.80
SOGT11T303 SSTM20	11.00	10.87	3.97	0.30

SCHNITTDATEN *Données de coupe*

Material Matière		Vc	fz	
		m/min	mm/U	
			SOMT11T308 SSTP20	SOGT11T303 SSTM20
Stahl <i>Acier</i>	niedriglegiert <i>Faiblement allié</i>	120 - 150	0.04 - 0.08	0.05 - 0.10
	legiert <i>Allié</i>	100 - 120	0.03 - 0.07	0.05 - 0.10
	hochlegiert <i>Fortement allié</i>	60 - 100	0.03 - 0.06	0.04 - 0.08
Rostfreier Stahl <i>Acier inoxydable</i>	ferritisch <i>Ferritique</i>	100 - 150	0.04 - 0.07	0.03 - 0.06
	austenitisch <i>Austénitique</i>	60 - 120	0.03 - 0.06	0.03 - 0.07
Guss <i>Fonte</i>	Grauguss <i>Fonte grise</i>	80 - 120	0.05 - 0.08	0.05 - 0.08
	Sphäroguss <i>Fonte à graphite sphéroïdal</i>	70 - 110	0.04 - 0.08	0.04 - 0.08
	Temperguss <i>Fonte malléable</i>	90 - 150	0.05 - 0.10	0.05 - 0.10

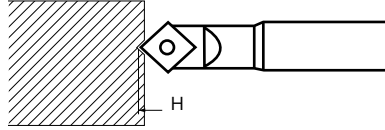
Verfahren *Procédé***Gravieren**
Graver

max. H = 0.7 mm

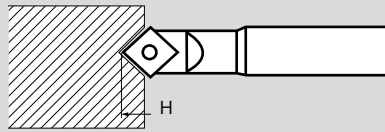
NC-Anbohren
Centrage NC

max. H = 5 mm

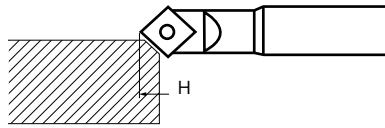
Fasenfräsen
Chanfreiner

max. H = 7 mm

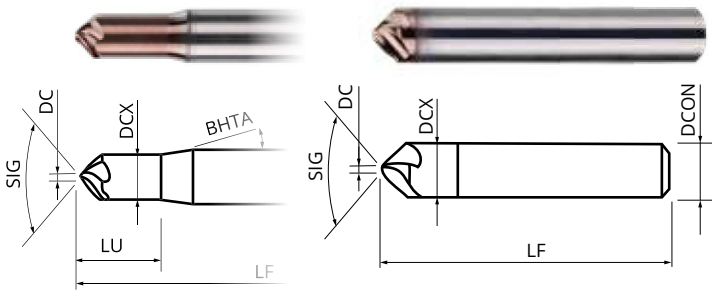

gilt für DCX < 3
S'applique à DCX < 3

gilt für DCX ≥ 3
S'applique à DCX ≥ 3



- Zur universellen Anwendung in Stahl bis HRC 55, rostfreiem Stahl, Guss und Superlegierungen
Pour utilisation universelle dans l'acier jusqu'à 55 HRC, l'acier inoxydable, la fonte et les superalliages
- Nicht für Bohr-Operationen geeignet
Ne convient pas pour les opérations de perçage

ABMESSUNGEN *Dimensions*

ArtNr. Référence (WGR. 9770)	DCX mm	DC mm	LU mm	LF mm	DCON mm	BHTA °	SIG °	ZEPF
CT-349R	2.5	0.38	5	40	3	15	90	5
CT-350R	3	0.45	-	40	3	-	90	5
CT-351R	4	0.60	-	50	4	-	90	5
CT-352R	6	0.90	-	58	6	-	90	5
CT-353R	8	1.20	-	64	8	-	90	5
CT-354R	10	1.50	-	75	10	-	90	5

SCHNITTDATEN *Données de coupe*

Material <i>Matière</i>	DC	≤ 2.5	2.6 - 4.0	4.1 - 6.0	≥ 6.1
	Vc m/min	fz mm/Z	fz mm/Z	fz mm/Z	fz mm/Z
Unlegierter Baustahl <i>Acier de construction non-allié</i>	60 - 100	0.005	0.01	0.015	0.02
Legierter Stahl / Hochlegierter Stahl <i>Acier allié / Acier fortement allié</i>	40 - 80	0.004	0.008	0.012	0.015
Rostfreier Stahl <i>Acier inoxydable</i>	40 - 80	0.005	0.01	0.015	0.02
Guss <i>Fonte</i>	60 - 100	0.005	0.01	0.015	0.02
Superlegierung <i>Superalliage</i>	40 - 80	0.005	0.01	0.015	0.02
Gehärteter Stahl <i>Acier trempé</i>	20 - 60	0.004	0.008	0.012	0.015

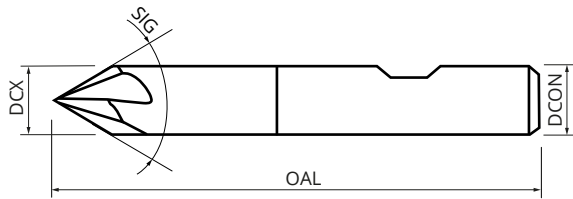

- Zur universellen Anwendung in Stahl, rostfreiem Stahl, Guss, Superlegierungen und Nichteisenmetallen *Pour utilisation universelle dans l'acier, l'acier inoxydable, la fonte, les superalliages et les métaux non ferreux*
- Nicht für Bohr-Operationen geeignet *Ne convient pas pour les opérations de perçage*

ABMESSUNGEN *Dimensions*

ArtNr. <i>Référence</i> (WGR. 8000)	DC mm	OAL mm	DCON mm	SIG °	ZEFP
FF060040*	4	54	4	60	4
FF060060	6	57	6	60	4
FF060080	8	63	8	60	4
FF060100	10	72	10	60	4
FF060120	12	83	12	60	4
FF060160	16	92	16	60	4

* mit HA-Schaft *Avec queue cylindrique*

SCHNITTDATEN *Données de coupe*

Material <i>Matière</i>	DC	≤ 4.0	4.1 - 8.0	8.1 - 12.0	≥ 12.1
	Vc m/min	fz mm/Z	fz mm/Z	fz mm/Z	fz mm/Z
Unlegierter Baustahl <i>Acier de construction non-allié</i>	80 - 120	0.015	0.03	0.04	0.06
Legierter Stahl / Hochlegierter Stahl <i>Acier allié / Acier fortement allié</i>	40 - 80	0.01	0.02	0.03	0.05
Rostfreier Stahl <i>Acier inoxydable</i>	40 - 80	0.01	0.02	0.03	0.05
Guss <i>Fonte</i>	80 - 120	0.015	0.04	0.04	0.06
Superlegierung <i>Superalliage</i>	40 - 80	0.008	0.015	0.02	0.03
Nichteisen Metall <i>Métaux non ferreux</i>	120 - 150	0.015	0.03	0.04	0.06

FF090

VHM-Fasenfräser
Fraise à chanfreiner



3-4
ZEPF

90°

*HA (h6)

HB (h6)

SST
COAT

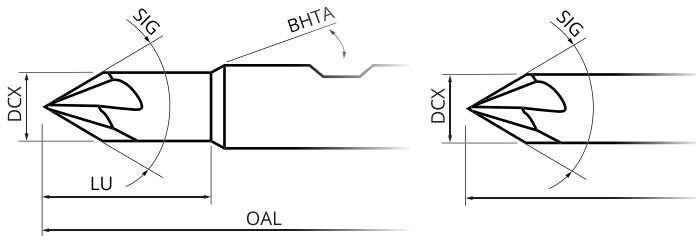

gilt für DCX < 3
S'applique à DCX < 3

gilt für DCX ≥ 3
S'applique à DCX ≥ 3



- Zur universellen Anwendung in Stahl, rostfreiem Stahl, Guss, Superlegierungen und Nichteisenmetallen *Pour utilisation universelle dans l'acier, l'acier inoxydable, la fonte, les superalliages et les métaux non ferreux*
- Nicht für Bohr-Operationen geeignet *Ne convient pas pour les opérations de perçage*

ABMESSUNGEN *Dimensions*

ArtNr. <i>Référence</i> (WGR. 8000)	DCX mm	LU mm	OAL mm	DCON mm	SIG °	BHTA °	ZEPF
FF090010*	1	5	38	3	90	22.5	3
FF090020*	2	5	38	3	90	22.5	3
FF090030*	3	-	38	3	90	-	4
FF090040*	4	-	54	4	90	-	4
FF090060	6	-	57	6	90	-	4
FF090080	8	-	63	8	90	-	4
FF090100	10	-	72	10	90	-	4
FF090120	12	-	83	12	90	-	4
FF090160	16	-	92	16	90	-	4
FF090200	20	-	104	20	90	-	4

* mit HA-Schaft *Avec queue cylindrique*

SCHNITTDATEN *Données de coupe*

Material <i>Matériau</i>	DC	≤ 2.0	2.1 - 4.0	4.1 - 8.0	8.1 - 12.0	≥ 12.1
	Vc m/min	fz mm/Z	fz mm/Z	fz mm/Z	fz mm/Z	fz mm/Z
Unlegierter Baustahl <i>Acier de construction non-allié</i>	80 - 120	0.005	0.015	0.03	0.04	0.06
Legierter Stahl / Hochlegierter Stahl <i>Acier allié / Acier fortement allié</i>	40 - 80	0.003	0.01	0.02	0.03	0.05
Rostfreier Stahl <i>Acier inoxydable</i>	40 - 80	0.003	0.01	0.02	0.03	0.05
Guss <i>Fonte</i>	80 - 120	0.005	0.015	0.04	0.04	0.06
Superlegierung <i>Superalliage</i>	40 - 80	0.002	0.008	0.015	0.02	0.03
Nichteisen Metall <i>Métaux non ferreux</i>	120 - 150	0.005	0.015	0.03	0.04	0.06

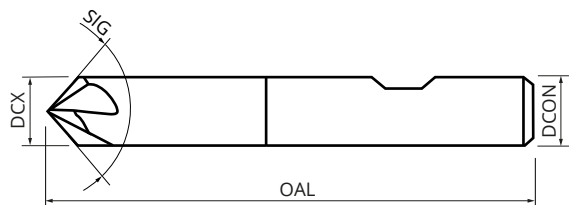

- Zur universellen Anwendung in Stahl, rostfreiem Stahl, Guss, Superlegierungen und Nichteisenmetallen *Pour utilisation universelle dans l'acier, l'acier inoxydable, la fonte, les superalliages et les métaux non ferreux*
- Nicht für Bohr-Operationen geeignet *Ne convient pas pour les opérations de perçage*

ABMESSUNGEN *Dimensions*

ArtNr. <i>Référence</i> (WGR. 8000)	DCX mm	OAL mm	DCON mm	SIG °	ZEPF
FF120040*	4	54	4	120	4
FF120060	6	57	6	120	4
FF120080	8	63	8	120	4
FF120100	10	72	10	120	4
FF120120	12	83	12	120	4
FF120160	16	92	16	120	4
FF120200	20	104	20	120	4

* mit HA-Schaft *Avec queue cylindrique*

SCHNITTDATEN *Données de coupe*

Material <i>Matière</i>	DC	≤ 4.0	4.1 - 8.0	8.1 - 12.0	≥ 12.1
	Vc m/min	fz mm/Z	fz mm/Z	fz mm/Z	fz mm/Z
Unlegierter Baustahl <i>Acier de construction non-allié</i>	80 - 120	0.015	0.03	0.04	0.06
Legierter Stahl / Hochlegierter Stahl <i>Acier allié / Acier fortement allié</i>	40 - 80	0.01	0.02	0.03	0.05
Rostfreier Stahl <i>Acier inoxydable</i>	40 - 80	0.01	0.02	0.03	0.05
Guss <i>Fonte</i>	80 - 120	0.015	0.04	0.04	0.06
Superlegierung <i>Superalliage</i>	40 - 80	0.008	0.015	0.02	0.03
Nichteisen Metall <i>Métaux non ferreux</i>	120 - 150	0.015	0.03	0.04	0.06



3-4

ZEPF



HA (h6)

SST

COAT

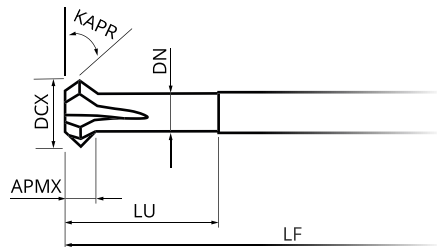
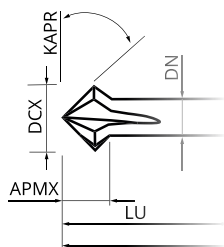

DCX ≤ 6 mm Stirn spitz zulaufend
DCX ≤ 6 mm front pointu

DCX ≥ 8 mm Spitze abgeflacht
DCX ≥ 8 mm pointe tronquée



- Zur universellen Anwendung in Stahl, rostfreiem Stahl, Guss, Superlegierungen und Nichteisenmetallen *Pour utilisation universelle dans l'acier, l'acier inoxydable, la fonte, les superalliages et les métaux non ferreux*
- VHM-Fasenfräser 45° für Vor- und Rückwärtsbearbeitung *Fraise biconique 45° en carbure pour usinage avant et arrière*

ABMESSUNGEN *Dimensions*

ArtNr. <i>Référence</i>	DCX	APMX	LU	DN	LF	DCON	KAPR	ZEPF
(WGR. 8000)	mm	mm	mm	mm	mm	mm	°	
VRE090020	2	1.4	8	1.2	100	6	45	3
VRE090030	3	2.0	8	2.0	100	6	45	4
VRE090040	4	3.0	10	2.0	100	6	45	4
VRE090060	6	4.0	15	4.0	100	6	45	4
VRE090080	8	4.0	-	-	100	6	45	4
VRE090100	10	3.2	-	-	100	6	45	4
VRE090120	12	4.3	-	-	100	6	45	4
VRE090160	16	5.0	-	-	100	10	45	4

SCHNITTDATEN *Données de coupe*

Material <i>Matière</i>	DC	≤ 4.0	4.1 - 8.0	8.1 - 12.0	≥ 12.1
	Vc	fz	fz	fz	fz
	m/min	mm/Z	mm/Z	mm/Z	mm/Z
Unlegierter Baustahl <i>Acier de construction non-allié</i>	70 - 90	0.010	0.016	0.020	0.026
Legierter Stahl / Hochlegierter Stahl <i>Acier allié / Acier fortement allié</i>	50 - 70	0.008	0.013	0.017	0.018
Rostfreier Stahl <i>Acier inoxydable</i>	30 - 50	0.008	0.013	0.017	0.018
Guss <i>Fonte</i>	60 - 80	0.010	0.016	0.020	0.023
Superlegierung <i>Superalliage</i>	30 - 45	0.005	0.010	0.015	0.015
Nichteisen Metall <i>Métaux non ferreux</i>	120 - 150	0.010	0.016	0.020	0.023

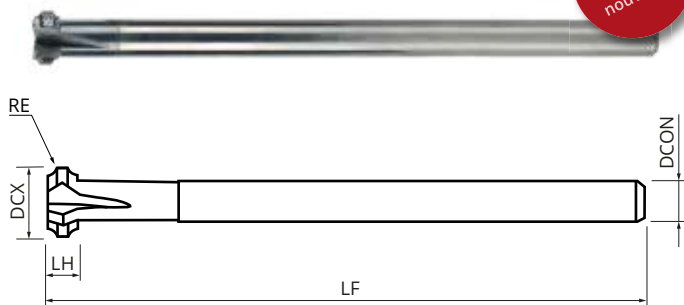

- Zur universellen Anwendung in Stahl, rostfreiem Stahl, Guss, Superlegierungen und Nichteisenmetallen *Pour utilisation universelle dans l'acier, l'acier inoxydable, la fonte, les superalliages et les métaux non ferreux*
- VHM-Viertelkreisfräser für Vor- und Rückwärtsbearbeitung *Fraise quart de cercle en carbure en plongeant et en tirant*

ABMESSUNGEN *Dimensions*

ArtNr. <i>Référence</i> (WGR. 8000)	DCX mm	RE mm	LH mm	LF mm	DCON mm	ZEFP
RVRE002080	8	0.2	2	100	6	4
RVRE003080	8	0.3	2	100	6	4
RVRE004080	8	0.4	2	100	6	4
RVRE005080	8	0.5	2	100	6	4
RVRE008100	10	0.8	4	100	6	4
RVRE010100	10	1.0	4	100	6	4
RVRE012100	10	1.2	4	100	6	4
RVRE015100	10	1.5	4	100	6	4

SCHNITTDATEN *Données de coupe*

Material <i>Matière</i>	RE	0.2	0.3	0.4	0.5	0.8	1.0	1.2	1.5
	Vc m/min	fz mm/Z	fz mm/Z	fz mm/Z	fz mm/Z	fz mm/Z	fz mm/Z	fz mm/Z	fz mm/Z
Unlegierter Baustahl <i>Acier de construction non-allié</i>	70 - 90	0.050	0.040	0.030	0.025	0.023	0.023	0.020	0.020
Legierter Stahl / Hochlegierter Stahl <i>Acier allié / Acier fortement allié</i>	50 - 70	0.037	0.030	0.025	0.020	0.018	0.018	0.015	0.015
Rostfreier Stahl <i>Acier inoxydable</i>	30 - 50	0.037	0.030	0.025	0.020	0.018	0.018	0.015	0.015
Guss <i>Fonte</i>	60 - 80	0.050	0.040	0.030	0.025	0.023	0.023	0.020	0.020
Superlegierung <i>Superalliage</i>	30 - 45	0.037	0.030	0.025	0.020	0.018	0.018	0.015	0.015
Nichteisen Metall <i>Métaux non ferreux</i>	120 - 150	0.050	0.040	0.030	0.025	0.023	0.023	0.020	0.020

SST
COAT

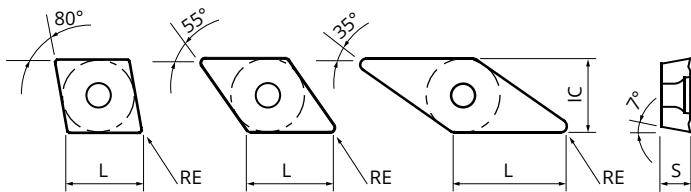

- Wendeplatte mit extra scharfer Geometrie und spezieller Beschichtung *Plaquette avec géométrie agressive et revêtement spécial*
- Hervorragend geeignet für Schlichtoperationen in Stahl, rostfreiem Stahl und Superlegierungen *Parfaitement adapté pour les opérations de finition dans l'acier, l'acier inoxydable et les superalliages*
- Gut geeignet für Schruppoperationen in Nicht-eisenmetallen *Convient pour l'ébauche dans les métaux non ferreux*

ABMESSUNGEN *Dimensions*

Artikelnummer <i>Référence</i>	L	IC	S	RE
(WGR. 7655)	mm	mm	mm	mm
CCGT09T302-AL-B	9.67	9.53	3.97	0.2
CCGT09T304-AL-B	9.67	9.53	3.97	0.4
CCGT09T308-AL-B	9.67	9.53	3.97	0.8
CCGT120402-AL-B	12.9	12.7	4.76	0.2
CCGT120404-AL-B	12.9	12.7	4.76	0.4
CCGT120408-AL-B	12.9	12.7	4.76	0.8

Artikelnummer <i>Référence</i>	L	IC	S	RE
(WGR. 7655)	mm	mm	mm	mm
DCGT11T302-AL-B	11.63	9.53	3.97	0.2
DCGT11T304-AL-B	11.63	9.53	3.97	0.4
DCGT11T308-AL-B	11.63	9.53	3.98	0.8

Artikelnummer <i>Référence</i>	L	IC	S	RE
(WGR. 7655)	mm	mm	mm	mm
VCGT110301-AL-B	11.07	6.35	3.18	0.1
VCGT110302-AL-B	11.07	6.35	3.18	0.2
VCGT110304-AL-B	11.07	6.35	3.18	0.4
VCGT160402-AL-B	16.61	9.53	4.76	0.2
VCGT160404-AL-B	16.61	9.53	4.76	0.4
VCGT160408-AL-B	16.61	9.53	4.76	0.8

SCHNITTDATEN *Données de coupe*

Material <i>Matière</i>	Stahl <i>Acier</i>			Rostfreier Stahl <i>Acier inoxydable</i>			Superlegierung <i>Superalliage</i>		
	Schlichten <i>Finition</i>			Schlichten <i>Finition</i>			Schlichten <i>Finition</i>		
Artikel <i>Article</i>	Vc	fn	ap	Vc	fn	ap	Vc	fn	ap
	m/min	mm/U	mm	m/min	mm/U	mm	m/min	mm/U	mm
CCGT09T302-AL-B	90 - 250	0.04 - 0.10	0.05 - 0.1	80 - 220	0.04 - 0.10	0.05 - 0.1	50 - 140	0.04 - 0.10	0.05 - 0.1
CCGT09T304-AL-B	90 - 250	0.06 - 0.15	0.1 - 0.2	80 - 220	0.06 - 0.15	0.1 - 0.2	50 - 140	0.06 - 0.15	0.1 - 0.2
CCGT09T308-AL-B	90 - 250	0.08 - 0.20	0.1 - 0.3	80 - 220	0.08 - 0.20	0.1 - 0.3	50 - 140	0.08 - 0.20	0.1 - 0.3
CCGT120402-AL-B	90 - 250	0.04 - 0.10	0.05 - 0.1	80 - 220	0.04 - 0.10	0.05 - 0.1	50 - 140	0.04 - 0.10	0.05 - 0.1
CCGT120404-AL-B	90 - 250	0.06 - 0.15	0.1 - 0.2	80 - 220	0.06 - 0.15	0.1 - 0.2	50 - 140	0.06 - 0.15	0.1 - 0.2
CCGT120408-AL-B	90 - 250	0.08 - 0.20	0.1 - 0.3	80 - 220	0.08 - 0.20	0.1 - 0.3	50 - 140	0.08 - 0.20	0.1 - 0.3
DCGT11T302-AL-B	90 - 250	0.04 - 0.10	0.05 - 0.1	80 - 220	0.04 - 0.10	0.05 - 0.1	50 - 140	0.04 - 0.10	0.05 - 0.1
DCGT11T304-AL-B	90 - 250	0.06 - 0.15	0.1 - 0.2	80 - 220	0.06 - 0.15	0.1 - 0.2	50 - 140	0.06 - 0.15	0.1 - 0.2
DCGT11T308-AL-B	90 - 250	0.08 - 0.20	0.1 - 0.3	80 - 220	0.08 - 0.20	0.1 - 0.3	50 - 140	0.08 - 0.20	0.1 - 0.3
VCGT110301-AL-B	90 - 250	0.01 - 0.05	0.05 - 0.1	80 - 220	0.01 - 0.05	0.05 - 0.1	50 - 140	0.01 - 0.05	0.05 - 0.1
VCGT110302-AL-B	90 - 250	0.04 - 0.10	0.05 - 0.1	80 - 220	0.04 - 0.10	0.05 - 0.1	50 - 140	0.04 - 0.10	0.05 - 0.1
VCGT110304-AL-B	90 - 250	0.06 - 0.12	0.05 - 0.1	80 - 220	0.06 - 0.12	0.05 - 0.1	50 - 140	0.06 - 0.12	0.05 - 0.1
VCGT160402-AL-B	90 - 250	0.04 - 0.10	0.05 - 0.1	80 - 220	0.04 - 0.10	0.05 - 0.1	50 - 140	0.04 - 0.10	0.05 - 0.1
VCGT160404-AL-B	90 - 250	0.06 - 0.15	0.1 - 0.2	80 - 220	0.06 - 0.15	0.1 - 0.2	50 - 140	0.06 - 0.15	0.1 - 0.2
VCGT160408-AL-B	90 - 250	0.08 - 0.20	0.1 - 0.3	80 - 220	0.08 - 0.20	0.1 - 0.3	50 - 140	0.08 - 0.20	0.1 - 0.3

Material <i>Matière</i>	Aluminium <i>Aluminium</i>					
	Schruppen <i>Ébauche</i>			Schlichten <i>Finition</i>		
Artikel <i>Article</i>	Vc	fn	ap	Vc	fn	ap
	m/min	mm/U	mm	m/min	mm/U	mm
CCGT09T302-AL-B	250 - 800	0.10 - 0.20	0.2 - 2.0	300 - 1200	0.05 - 0.12	0.05 - 0.1
CCGT09T304-AL-B	250 - 800	0.10 - 0.25	0.2 - 2.5	300 - 1200	0.08 - 0.20	0.1 - 0.2
CCGT09T308-AL-B	250 - 800	0.15 - 0.35	0.3 - 3.0	300 - 1200	0.10 - 0.25	0.1 - 0.3
CCGT120402-AL-B	250 - 800	0.10 - 0.20	0.1 - 2.5	300 - 1200	0.05 - 0.12	0.05 - 0.1
CCGT120404-AL-B	250 - 800	0.10 - 0.25	0.2 - 3.0	300 - 1200	0.08 - 0.20	0.1 - 0.2
CCGT120408-AL-B	250 - 800	0.15 - 0.35	0.3 - 3.5	300 - 1200	0.10 - 0.25	0.1 - 0.3
DCGT11T302-AL-B	250 - 800	0.10 - 0.20	0.2 - 2.0	300 - 1200	0.05 - 0.12	0.05 - 0.1
DCGT11T304-AL-B	250 - 800	0.10 - 0.25	0.2 - 3.0	300 - 1200	0.08 - 0.20	0.1 - 0.2
DCGT11T308-AL-B	250 - 800	0.15 - 0.35	0.3 - 3.5	300 - 1200	0.10 - 0.25	0.1 - 0.3
VCGT110301-AL-B	250 - 800	0.10 - 0.20	0.1 - 1.5	300 - 1200	0.05 - 0.12	0.05 - 0.1
VCGT110302-AL-B	250 - 800	0.10 - 0.20	0.2 - 2.0	300 - 1200	0.05 - 0.12	0.05 - 0.1
VCGT110304-AL-B	250 - 800	0.13 - 0.24	0.2 - 2.0	300 - 1200	0.05 - 0.12	0.05 - 0.1
VCGT160402-AL-B	250 - 800	0.10 - 0.20	0.2 - 2.0	300 - 1200	0.05 - 0.12	0.05 - 0.1
VCGT160404-AL-B	250 - 800	0.10 - 0.25	0.2 - 2.5	300 - 1200	0.08 - 0.20	0.1 - 0.2
VCGT160408-AL-B	250 - 800	0.15 - 0.35	0.3 - 3.0	300 - 1200	0.10 - 0.25	0.1 - 0.3

Berechnungsformeln *Formules de calcul*

FRÄSEN *Fraisage*

Parameter <i>Paramètre</i>	Formel <i>Formule</i>	Einheit <i>Unité</i>
-------------------------------	--------------------------	-------------------------

Drehzahl
Vitesse de rotation

$$n = \frac{v_c \times 1000}{D_c \times \pi} \quad [\text{min}^{-1}]$$

Schnittgeschwindigkeit
Vitesse de coupe

$$v_c = \frac{D_c \times \pi \times n}{1000} \quad [\text{m/min}]$$

Vorschubgeschwindigkeit
Vitesse d'avance

$$v_f = f_z \times z \times n \quad [\text{mm/min}]$$

Zahnvorschub
Avance par dent

$$f_z = \frac{v_f}{z \times n} \quad [\text{mm/z}]$$

$$h_m = \frac{\left(114,7 \times f_z \times \sin \kappa \times \left(\frac{a_e}{D_c} \right) \right)}{\varphi_s}$$

$$f_z = \frac{h_m \times \varphi_s}{114,7 \times \sin \kappa \times \left(\frac{a_e}{D_c} \right)}$$

Mittlere Spannungsstärke
Épaisseur de copeau moyenne

oder *ou* $h_m \cong f_z \times \sqrt{\frac{a_e}{D_c}} \quad [\text{mm}]$

$$f_z = \frac{h_m}{\sqrt{\frac{a_e}{D_c}}}$$

als Näherungsformel für
comme formule d'approximation pour

$$\frac{a_e}{D_c} < 30\%$$

FRÄSEN *Fraisage*

Parameter <i>Paramètre</i>	Formel <i>Formule</i>	Einheit <i>Unité</i>
-------------------------------	--------------------------	-------------------------

bei zentraler Stellung des Fräasers
avec la fraise en position centrale

$$\varphi_s \cong 2 \times \arcsin \left(\frac{a_e}{D_c} \right)$$

Eingriffswinkel
Angle d'attaque

bei außermittiger Stellung des Fräasers
avec la fraise en position excentrée [°]

$$\varphi_s \cong 90^\circ + \arcsin \frac{a_e - \left(\frac{D_c}{2} \right)}{\left(\frac{D_c}{2} \right)}$$

Spezif. Schnittkraft
Force de coupe spécifique

$$k_c = \frac{1 - 0,01 \times y_0}{h_m^{m_c}} \times k_{c1,1} \quad [\text{N/mm}^2]$$

Leistungsbedarf
Puissance requise

$$P_{\text{mot}} = \frac{Q \times k_c}{60000 \times \eta} \quad [\text{kW}]$$

Zeitspanvolumen
Volume de copeaux en temps

$$Q = \frac{a_e \times a_p \times v_f}{1000} \quad [\text{cm}^3/\text{min}]$$

- Die Schnittdaten sind Richtwerte. Je nach Aufspannung und Maschine sind die Daten entsprechend anzupassen.

Les paramètres de coupe mentionnés sont indicatifs. Selon le type de machine et les conditions de travail, les données doivent être ajustées en conséquence.

- Anwendung dieser Schnittdaten auf eigene Verantwortung. Alle Angaben ohne Gewähr, Modell-, Farb- und Preisänderungen vorbehalten.

L'application des paramètres se fait à vos propres risques. Toutes les données sont sous réserve de modifications des modèles, couleurs et prix.

- Die Preise gelten je Stück, exkl. der gesetzlichen MwSt. Im Übrigen gelten unsere AGB's (www.sixsigmatools.com/AGB.pdf)

Les prix s'appliquent par article, hors TVA légale. À tous les autres égards, nos CGV (www.sixsigmatools.com/cgv.pdf) s'appliquent.

- Technische Änderungen ohne Vorankündigung möglich. Es gelten unsere allgemeinen Geschäftsbedingungen. | Drucklegung 2022

Les informations techniques peuvent être modifiées sans préavis. Selon nos termes et conditions en vigueur. | Impression 2022

Six Sigma Tools AG

Blegistrasse 13
6340 Baar
Schweiz

Tel.: +41 55 245 50 50

E-Mail: info@sixsigmatools.ch

Web: www.sixsigmatools.ch

Six Sigma Tools AG

Blegistrasse 13
6340 Baar
Suisse

Téléphone : +41 55 245 50 50

E-mail : info@sixsigmatools.ch

Web : www.sixsigmatools.ch